

DESCRIPTION

The Encounter™ redefines ambient lighting by being the first fixture to blend modern contemporary styling with the innovative WaveStream™ technology to deliver exceptional performance and superior energy savings. Encounter's highly efficient LED system with advance optical design delivers an unparalleled combination of optimal light uniformity for enhanced visual comfort and superior efficiency for greater energy savings.

Encounter is compatible with all of today's popular ceiling systems and available in a variety of configurations for application versatility. Its perfect balance of form and function make it an ideal choice for commercial office spaces, schools, hospitals, retail and other indoor ambient applications.

SPECIFICATION FEATURES

Construction

Shallow 3-1/4" deep housing is extruded aluminum frame and injected molded composite end plates. End plates are securely attached with screws for strength and rigidity and the elimination of gaps. End plates have accessory grid-lock feature for safety and convenience. Four auxiliary fixture end suspension points are provided. Large access plate for supply connection.

Controls

The Encounter LED is Powered by Fifth Light, with a standard 0-10V continuous dimming driver that works with any 0-10V control/dimmer. Combine with energy saving products like occupancy sensors, daylighting controls and lighting relay panels to maximize energy savings. In addition, the Encounter can include a factory-installed integrated sensor system for occupancy and daylight dimming control and manual control from an optional handheld remote. Or, specify the Digital Addressable Lighting Interface (DALI) drivers, dimmable down to

1% with the HD option, for use with Fifth Light controls. See ordering information for details on all three options.

Electrical

Long-life LED system coupled with electrical driver to deliver optimal performance. LED's available in 3000K, 3500K, 4000K or 5000K with a typical CRI \leq 85. Projected life is 60,000 hours at 78% lumen output. Electronic drivers are available for 120-277V applications.

Emergency Battery Pack Option

Optional 120v-277v integral emergency battery pack is available in 7-watts or 14-watts to meet critical life-safety lighting requirements. The 90-minute batteries provide constant power to the LED system, ensuring code-compliance. A test switch/indicator button can be tested safely from the ground using a laser pointer, while the patented EZ Key prevents accidental discharge of the battery during construction. See ordering information for details.

Catalog #

Type

Project

Comments

Date

Prepared by

Driver Access

Drivers can be accessed via plenum.

Finish

Durable frame has high reflectance baked matte white enamel finish for luminous uniformity.

Optics

Precision formed optical assembly with positively retained high optical grade acrylic lenses provide a directed optical distribution using WaveStream technology.

Compliance

Components are UL recognized. Indoor luminaires are cULus and CSA listed for 25° C ambient environments, RoHS compliant, and comply with IESNA LM-79. LEDs comply with LM-80 standards. DesignLights Consortium® Qualified. Refer to www.designlights.org Qualified Products List under Family Models for details.

Warranty

Five year warranty.



**24EN
LED**

**2' X 4' TROFFER
LED MODULE**

Specification Grade Troffer



powered by
fifthlight
technology

CERTIFICATION DATA

cULus - 1598 and 2043**
Damp Location Listed
CSA
IC Rated
LM79/LM80 Compliant
ROHS Compliant
DesignLights Consortium® Qualified
NOM Compliant

*See Drywall Frame Kit Accessory in Ordering Information section.
**Fixture construction is suitable for use in Air-handling and plenum rated spaces in accordance with Section 300.22 (C) of the National Electrical Code, Section 4.3.11.2.6.5 of NFPA 90A and Section 602.2.1.4 of ICC.

LINEAR DISCONNECT

Safe and convenient means of disconnecting power



ADF130513
2015-09-09 15:40:27

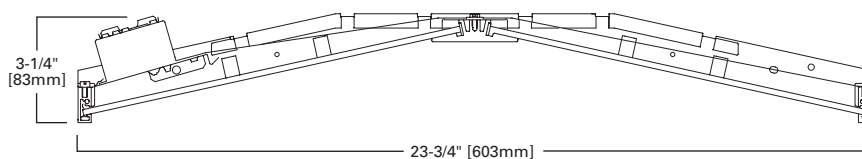

MOUNTING DATA

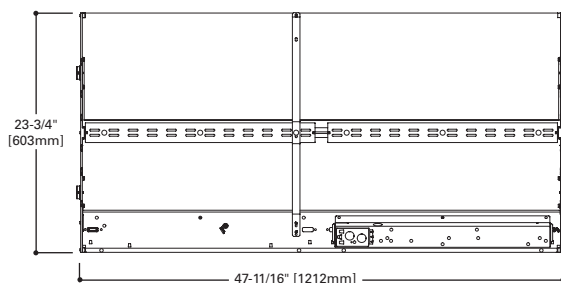

LAMP CONFIGURATIONS

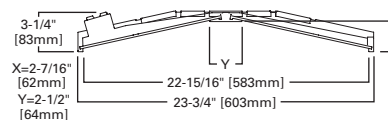

CEILING COMPATIBILITY

G
Grid/Lay-in
Standard

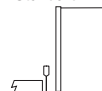

F
Drywall Frame
Kit



**Ceiling
Type**
Exposed Grid
Concealed T
Slot Grid
Flange

**Trim
Type**
G
G or T
G or T
*

PHOTOMETRICS

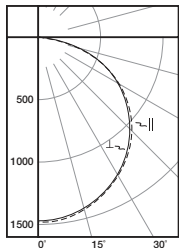

24EN-LD1-45-UNV-L835-CD1-U
 Electronic Driver
 Linear LED 3500K
 Spacing criterion:
 (||) 1.3 x mounting
 height, (⊥) 1.3 x
 mounting height
 Lumens: 4504
 Input Watts: 47.0W
 Efficacy: 96 LPW
 Test Report:
 24EN-LD1-44-UNV-
 L835-CD1-U.IES

Candlepower				
Angle	Along	45°	Across ⊥	
0	1471	1471	1471	
5	1473	1467	1467	
10	1456	1448	1449	
15	1425	1417	1417	
20	1384	1374	1371	
25	1332	1321	1315	
30	1273	1260	1251	
35	1204	1188	1179	
40	1128	1111	1102	
45	1046	1028	1022	
50	954	936	932	
55	854	834	832	
60	744	722	728	
65	625	601	617	
70	494	480	472	
75	357	347	302	
80	219	195	210	
85	99	96	97	
90	0	0	0	

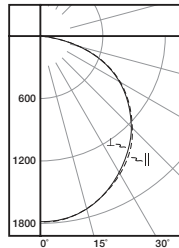

24EN-LD1-54-UNV-L835-CD1-U
 Electronic Driver
 Linear LED 3500K
 Spacing criterion:
 (||) 1.3 x mounting
 height, (⊥) 1.3 x
 mounting height
 Lumens: 5421
 Input Watts: 54.4W
 Efficacy: 100 LPW
 Test Report:
 24EN-LD1-54-UNV-
 L835-CD1-U.IES

Candlepower				
Angle	Along	45°	Across ⊥	
0	1782	1782	1782	
5	1781	1779	1780	
10	1760	1758	1759	
15	1724	1720	1720	
20	1674	1669	1664	
25	1614	1605	1595	
30	1537	1526	1514	
35	1455	1443	1424	
40	1359	1346	1331	
45	1260	1241	1231	
50	1145	1130	1119	
55	1023	1001	996	
60	890	865	865	
65	745	716	728	
70	587	571	554	
75	422	413	357	
80	260	232	247	
85	118	112	115	
90	0	0	0	

Coefficients of Utilization

rc rw RCR	Effective floor cavity reflectance																							
	80%				70%				50%				30%				10%				0%			
	70	50	30	10	70	50	30	10	50	30	10	50	30	10	50	30	10	50	30	10	50	30	10	0
0	119	119	119	119	116	116	116	116	111	111	111	106	106	106	102	102	102	100						
1	108	103	99	95	105	101	97	93	97	93	90	93	90	87	89	87	85	83						
2	98	89	82	76	95	87	81	75	84	78	74	81	76	72	77	74	70	68						
3	89	78	70	63	86	76	69	62	73	67	61	71	65	60	68	63	59	57						
4	81	69	60	53	79	68	59	53	65	58	52	63	56	51	60	55	50	48						
5	75	61	52	45	72	60	52	45	58	50	45	56	49	44	54	48	44	41						
6	69	55	46	39	67	54	45	39	52	45	39	51	44	38	49	43	38	36						
7	64	50	41	35	62	49	41	34	47	40	34	46	39	34	45	38	34	32						
8	59	45	37	31	58	45	36	31	43	36	30	42	35	30	41	35	30	28						
9	55	42	33	28	54	41	33	28	40	33	27	39	32	27	38	32	27	25						
10	52	38	30	25	51	38	30	25	37	30	25	36	29	25	35	29	25	23						

Coefficients of Utilization

rc rw RCR	Effective floor cavity reflectance																							
	80%				70%				50%				30%				10%				0%			
	70	50	30	10	70	50	30	10	50	30	10	50	30	10	50	30	10	50	30	10	50	30	10	0
0	119	119	119	119	116	116	116	116	111	111	111	106	106	106	102	102	102	100						
1	108	103	99	95	105	101	97	93	97	93	90	93	90	87	89	87	85	83						
2	98	89	82	76	95	88	81	75	84	78	74	81	76	72	78	74	70	68						
3	89	78	70	63	87	77	69	62	74	67	61	71	65	60	68	63	59	57						
4	81	69	60	53	79	68	59	53	65	58	52	63	56	51	61	55	51	48						
5	75	62	52	45	73	60	52	45	58	51	45	56	49	44	54	48	44	42						
6	69	55	46	39	67	54	46	39	52	45	39	51	44	39	49	43	38	36						
7	64	50	41	35	62	49	41	35	48	40	34	46	39	34	45	39	34	32						
8	59	46	37	31	58	45	37	31	44	36	31	42	35	30	41	35	30	28						
9	55	42	33	28	54	41	33	28	40	33	28	39	32	27	38	32	27	25						
10	52	39	30	25	51	38	30	25	37	30	25	36	29	25	35	29	25	23						

Zonal Lumen Summary

Zone	Lumens	%Fixture
0-30	1149	25.5
0-40	1893	42.0
0-60	3436	76.3
0-90	4504	100.0
0-180	4504	100.0

Luminance Data

Angle in Deg	Average 0-Deg cd/sm	Average 45-Deg cd/sm	Average 90-Deg cd/sm
45	1990	1955	1944
55	2003	1956	1951
65	1989	1913	1964
75	1855	1803	1569
85	1528	1481	1497

Zonal Lumen Summary

Zone	Lumens	%Fixture
0-30	1393	25.7
0-40	2295	42.3
0-60	4152	76.6
0-90	5421	100.0
0-180	5421	100.0

Luminance Data

Angle in Deg	Average 0-Deg cd/sm	Average 45-Deg cd/sm	Average 90-Deg cd/sm
45	2397	2361	2342
55	2399	2347	2336
65	2371	2279	2317
75	2193	2146	1855
85	1821	1728	1775

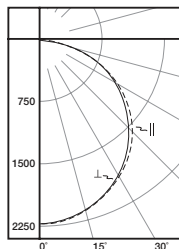

24EN-LD1-67-UNV-L835-CD1-U
 Electronic Driver
 Linear LED 3500K
 Spacing criterion:
 (||) 1.3 x mounting
 height, (⊥) 1.3 x
 mounting height
 Lumens: 6730
 Input Watts: 70.2W
 Efficacy: 96 LPW
 Test Report:
 24EN-LD1-66-UNV-
 L835-CD1-U.IES

Candlepower				
Angle	Along	45°	Across ⊥	
0	2212	2212	2212	
5	2219	2205	2205	
10	2192	2178	2179	
15	2149	2132	2132	
20	2086	2068	2063	
25	2009	1989	1976	
30	1917	1893	1878	
35	1814	1787	1768	
40	1695	1667	1651	
45	1570	1541	1526	
50	1431	1400	1388	
55	1280	1243	1230	
60	1111	1071	1073	
65	933	886	908	
70	730	706	689	
75	524	510	436	
80	323	286	307	
85	149	142	141	
90	0	0	0	

Coefficients of Utilization

rc rw RCR	Effective floor cavity reflectance																							
	80%				70%				50%				30%				10%				0%			
	70	50	30	10	70	50	30	10	50	30	10	50	30	10	50	30	10	50	30	10	50	30	10	0
0	119	119	119	119	116	116	116	116	111	111	111	106	106	106	102	102	102	100						
1	108	103	99	95	105	101	97	93	97	93	90	93	90	87	89	87	85	83						
2	98	89	82	76	95	88	81	75	84	78	74	81	76	72	78	74	70	68						
3	89	78	70	63	87	77	69	62	74	67	61	71	65	60	68	63	59	57						
4	81	69	60	53	79	68	59	53	65	58	52	63	56	51	61	55	51	48						
5	75	62	52	45	73	60	52	45	58	51	45	56	49	44	54	48	44	42						
6	69	55	46	40	67	54	46	39	52	45	39	51	44	39	49	43	38	36						
7	64	50	41	35	62	49	41	35	48	40	34	46	39	34	45	39	34	32						
8	59	46	37	31	58	45	37	31	44	36	31	42	35	30	41	35	30	28						
9	55	42	33	28	54	41	33	28	40	33	28	39	32	27	38	32	27	25						
10	52	39	30	25	51	38	30	25	37	30	25	36	29	25	35	29	25	23						

Zonal Lumen Summary

Zone	Lumens	%Fixture
0-30	1730	25.7
0-40	2849	42.3
0-60	5155	76.6
0-90	6730	100.0
0-180	6730	100.0

Luminance Data

Angle in Deg	Average 0-Deg cd/sm	Average 45-Deg cd/sm	Average 90-Deg cd/sm
45	2986	2931	2903
55	3002	2915	2884
65	2969	2820	2890
75	2723	2650	2266
85	2299	2191	2176

LUMEN MAINTENANCE

Ambient Temperature	TM-21 Lumen Maintenance (60,000 hours)	Theoretical L70 (Hours)
25°C	> 78%	> 92,000

ENERGY AND PERFORMANCE DATA BY CATALOG NUMBER

Stock or MTO*	Catalog Logic (Curved)	Delivered Lumens	Watts	Efficacy (LPW)
MTO	24EN-LD1-30-UNV-L830-CD1-U	2928	29.8	98
MTO	24EN-LD1-30-UNV-L835-CD1-U	3040	30.1	101
MTO	24EN-LD1-30-UNV-L840-CD1-U	3114	29.9	104
MTO	24EN-LD1-30-UNV-L850-CD1-U	3294	29.9	110
MTO	24EN-LD1-34-UNV-L830-CD1-U	3326	34.3	97
MTO	24EN-LD1-34-UNV-L835-CD1-U	3449	34.5	100
MTO	24EN-LD1-34-UNV-L840-CD1-U	3536	34.4	103
MTO	24EN-LD1-34-UNV-L850-CD1-U	3740	34.4	109
MTO	24EN-LD1-40-UNV-L830-CD1-U	3898	41.0	95
MTO	24EN-LD1-40-UNV-L835-CD1-U	4039	41.3	98
MTO	24EN-LD1-40-UNV-L840-CD1-U	4141	41.1	101
MTO	24EN-LD1-40-UNV-L850-CD1-U	4381	41.1	107
MTO	24EN-LD1-45-UNV-L830-CD1-U	4333	46.7	93
STOCK	24EN-LD1-45-UNV-L835-CD1-U	4504	47.0	96
STOCK	24EN-LD1-45-UNV-L840-CD1-U	4618	46.8	99
MTO	24EN-LD1-45-UNV-L850-CD1-U	4885	46.8	104
MTO	24EN-LD1-49-UNV-L830-CD1-U	4884	49.1	99
MTO	24EN-LD1-49-UNV-L835-CD1-U	4962	49.3	101
MTO	24EN-LD1-49-UNV-L840-CD1-U	5141	49.4	104
MTO	24EN-LD1-49-UNV-L850-CD1-U	5438	49.4	110
MTO	24EN-LD1-54-UNV-L830-CD1-U	5329	54.3	98
STOCK	24EN-LD1-54-UNV-L835-CD1-U	5421	54.4	100
STOCK	24EN-LD1-54-UNV-L840-CD1-U	5614	54.6	103
MTO	24EN-LD1-54-UNV-L850-CD1-U	5938	54.6	109
MTO	24EN-LD1-58-UNV-L830-CD1-U	5763	59.5	97
MTO	24EN-LD1-58-UNV-L835-CD1-U	5856	59.5	98
MTO	24EN-LD1-58-UNV-L840-CD1-U	6070	59.8	102
MTO	24EN-LD1-58-UNV-L850-CD1-U	6421	59.8	107
MTO	24EN-LD1-67-UNV-L830-CD1-U	6598	70.0	94
STOCK	24EN-LD1-67-UNV-L835-CD1-U	6730	70.2	96
STOCK	24EN-LD1-67-UNV-L840-CD1-U	6938	70.2	99
MTO	24EN-LD1-67-UNV-L850-CD1-U	7339	70.2	105
MTO	24EN-LD1-70-UNV-L830-CD1-U	6948	74.9	93
MTO	24EN-LD1-70-UNV-L835-CD1-U	7077	74.9	94
MTO	24EN-LD1-70-UNV-L840-CD1-U	7303	74.9	98
MTO	24EN-LD1-70-UNV-L850-CD1-U	7725	74.9	103
MTO	24EN-LD1-74-UNV-L830-CD1-U	7341	80.0	92
MTO	24EN-LD1-74-UNV-L835-CD1-U	7443	80.0	93
MTO	24EN-LD1-74-UNV-L840-CD1-U	7683	80.0	96
MTO	24EN-LD1-74-UNV-L850-CD1-U	8127	80.0	102

*Made to order (MTO) requires a typical four week lead time.

ORDERING INFORMATION

SAMPLE NUMBER: 24EN-LD1-67-UNV-L835-CD1-SVPD1-U

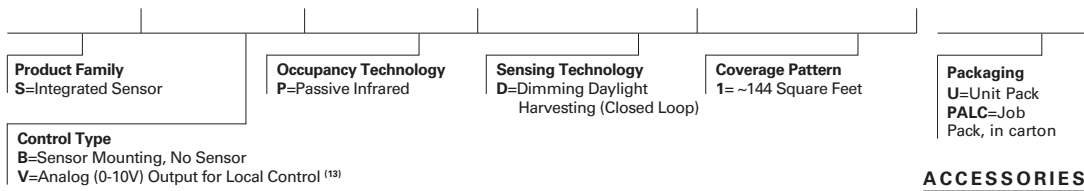
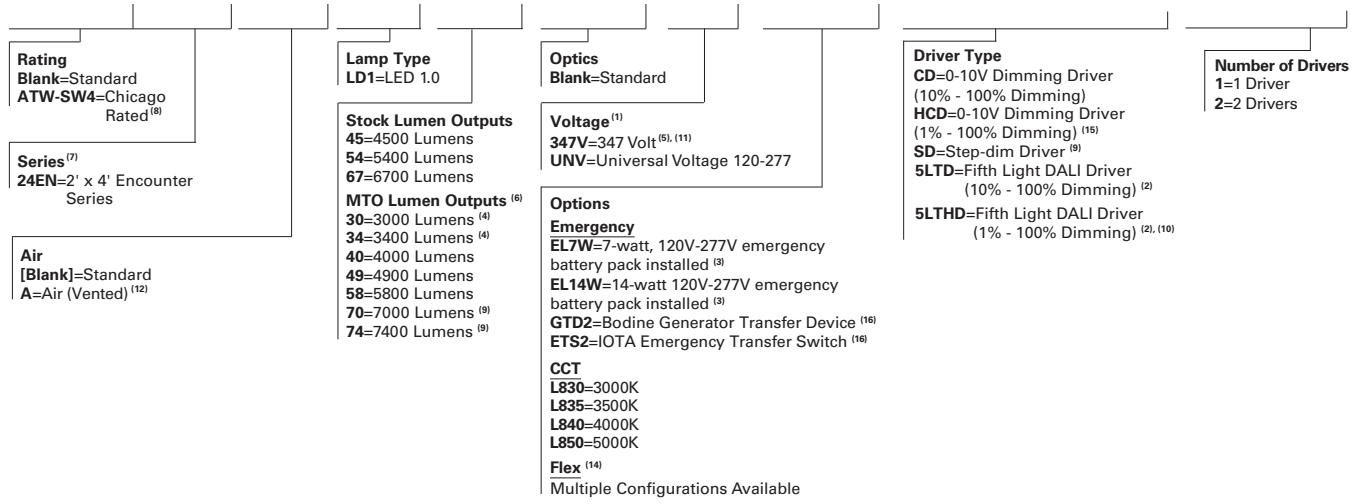

NOTES: ⁽¹⁾Products also available in non-US voltages and frequencies for international markets. ⁽²⁾Must be used in conjunction with a DALI control system. For complete DALI solutions by Fifth Light, visit www.eaton.com/lightingsystems ⁽³⁾With integral test switch/indicator/laser test. For approximate delivered lumens multiply the lumens per watt of the desired fixture by the wattage of the emergency battery pack (100 lm/W x 7=700 lumens). IES-format photometry for luminaire under emergency operation available. ⁽⁴⁾Step-dim driver not available with 3,000 and 3,400 lumen options. ⁽⁵⁾347V emergency option not available. ⁽⁶⁾Made-to-order (MTO) requires four week lead time. ⁽⁷⁾DesignLights Consortium™ Qualified and classified for DLC Standard (all lumen packages), refer to www.designlights.org for details. ⁽⁸⁾Chicago rated version does not allow for row mounting. ⁽⁹⁾Two drivers only required for 7000 and 7400 lumen options with step-dim driver. ⁽¹⁰⁾Two drivers required for 5LTHD option for 5800 lumens and up. ⁽¹¹⁾347V option not available with 7400 lumen package. ⁽¹²⁾Air version is vented but does not meet air handling requirements; a 6% reduction in delivered lumens is experienced with this option. ⁽¹³⁾Integral sensor works only with "CD" driver and is factory prewired to the driver for stand-alone control. ⁽¹⁴⁾Flex does not include dimming leads. Control leads provided by others. ⁽¹⁵⁾HCD driver option is not available with 6700, 7000 and 7400 lumen packages. ⁽¹⁶⁾Used to transfer fixture to secondary power source for life-safety operation. When used with a dimming fixture, two devices are required to ensure control is disabled while operating under emergency power.

Specifications & dimensions subject to change without notice. Consult your Eaton Representative for availability and ordering information.

ACCESSORIES

- T3A END E.O. BRACKET PARTS BAG (Standard with fixture)
- DF-24-W=2' x 4' Drywall Frame Kit
- SK-24-WS=2' x 4' Shallow Surface Mount Kit
- SK-24-WT=2' x 4' Tall Surface Mount Kit
- DF10P-C_=Decorator Dimmer, 0-10V
- SF10P-_=Decorator Slide Dimmer, 0-10V
- HHPRG-MS=Programming Remote for Integrated Sensor
- ISHH-02=Personal Control Remote for Integrated Sensor

SHIPPING DATA

Catalog No.	Wt.
24EN-LD1-45	28 lbs.
24EN-LD1-54	28 lbs.
24EN-LD1-67	28 lbs.



Eaton
1121 Highway 74 South
Peachtree City, GA 30269
P: 770-486-4800
www.eaton.com/lighting

Specifications and dimensions subject to change without notice.

INTEGRATED SENSOR

Description

This innovative luminaire-integrated sensor control system is optimized for code-compliant occupancy detection and daylight harvesting – all from within the foot print of Metalux's award-winning recessed ambient luminaires.

No New Wires

An in-place fixture retrofit is all that's needed to meet most energy codes in commercial spaces. The sensor system is factory wired to the luminaire, switching on or off based on occupancy, and dimming the light when enough daylight is available.

Sophisticated lighting control without commissioning

The luminaire-integrated sensor system offers out-of-the-box operation using thoughtful default settings.

Flexibility and Individual Control

When the application demands more, the sensor system has the option to make changes using a remote control. The remote allows changes from the default settings for occupancy, target light level, preset lighting levels, and more.

Cost-effective, Stand-alone Operation

With a single product to mount and a single electrical connection to make, the Metalux luminaire with an integrated sensor system saves money on the total installed cost when occupancy or daylight harvesting controls are needed. The integrated sensor system works stand-alone, without the need for additional switches and dimmers. When manual-on, manual dimming or other code-required control schemes are needed, please see the comprehensive offering of Greengate and Fifth Light solutions from Cooper Controls at www.coopercontrol.com.

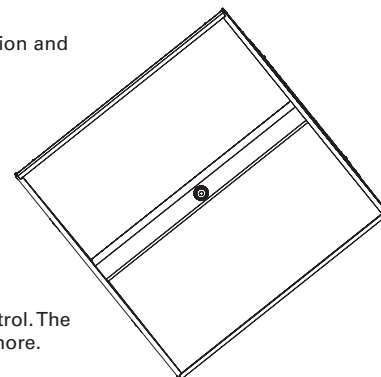

Metalux Integrated Sensor Sequence of Operation

The occupancy sensing portion of the sensor uses Passive Infrared (PIR) technology with Auto-on/Auto-off operation. The small lens in the center of the sensor directs the view of a passive infrared occupancy detector to sense occupants moving through the room. To trigger the light on, an occupant must cross at least two passive infrared beams. When motion in the coverage area ceases, the sensor logic concludes the room is unoccupied, and begins a count-down timer. By default, the timer is factory-set to 20 minutes, and can be adjusted to 5, 10, 15 and 20 minutes using the optional remote control, model number HHPRG-MS. Any motion detected during the count-down timer will cause the light to remain on and resets the timer. When motion is detected, a red LED will blink. In addition to the default on/off functionality, the sensor has an Energy Saver feature, where the light can be set to dim to a preset level after the sensor detects no occupancy for half of the count-down timer, when the timer is complete the lighting will change to the unoccupied setting. The Energy Saver feature works when the count-down timer is set to at least 15 minutes, and the preset level and feature are configured using the optional remote control. See the Sensor Programming Guide that comes with the HHPRG-MS remote for details on this feature. The sensitivity of the occupancy detection can be adjusted, using the HHPRG-MS remote. By default, the sensor operates at the full detection range shown on the coverage pattern diagram. Using the "LO" button on the HHPRG-MS remote, reduces the sensor detection range by 50%. Full coverage can be restored at any time by pressing the "HI" button on the remote. The red LED indicator will blink repeatedly to confirm any programming change.

The dimming daylight harvesting portion of the sensor uses a small photo sensor located next to the occupancy sensing lens. The sensor continuously measures the available light in the room, even when the fixture is turned off. This allows sensor to operate in one of three daylighting modes, where the artificial light from the paired Metalux luminaire can adjust the light based on the amount of ambient light from surrounding natural and artificial light sources. Since the sensor measures light from its luminaire along with other light sources, this sensor follows a closed-loop dimming daylight harvesting style. The first mode, Daytime, is active when the sensor detects light of at least 100 lux in the room. In Daytime mode, when the light is turned on after detecting occupancy, the sensor will begin balancing the luminaire light level relative to the total available light it measures. The default light balancing target in daytime mode is 500 lux. This level can be adjusted higher or lower using the optional HHPRG-MS remote, and pressing "SET" and then the "DO" (Daytime Occupied) button to store the new light level. Similarly, the Daytime Unoccupied, "DU" has a default of level of 0 lux, or off, but can be adjusted higher to prevent the lights from turning off completely when unoccupied. More details on this function are found in the Sensor Programming Guide for the HHPRG-MS remote.

The next two modes, Twilight and Nighttime, function in a similar way, allowing the artificial light to adjust to different levels based on the surroundings. While primarily for use in outdoor luminaires, these modes are available for use in areas with a wide range of natural light, including atriums, day lit stairwells, and rooms with large or continuous windows. The Twilight mode is active when the sensor detects 50-100 lux in the off position, and has a 300 lux default light balancing target. The Nighttime mode is active when the sensor detects less than 50 lux, and has a 250 lux default light balancing target. Like the Daytime mode, there are separate settings for Twilight Occupied ("TO"), Twilight Unoccupied ("TU"), Nighttime Occupied ("NO") and Nighttime Unoccupied ("NU") which can be adjusted and set using the optional HHPRG-MS remote.

In addition to programming the sensor, the optional HHPRG-MS remote can be used for personal control to adjust the lighting temporarily override the functions of the sensor temporarily. The remote has raise/lower buttons to adjust the light level for special tasks, as well as a power button to turn the lights on or off. Unless the SET button and another function is selected, any changes made using these buttons will revert to the programmed settings after the sensor has detected no occupancy for its programmed time out, and turned off the lighting. The next time the sensor detects occupancy, it will revert to its programmed settings for count-down timer and light balancing.

Coverage

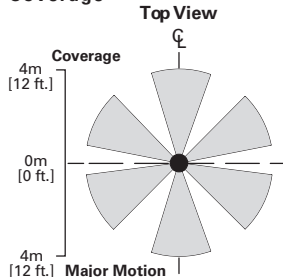

Side View

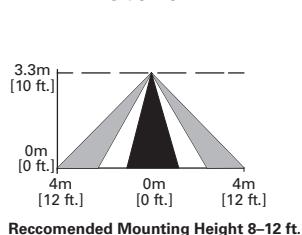

Optional Remote Control



HHPRG-MS Remote

DESCRIPTION

The Encounter™ redefines ambient lighting by being the first fixture to blend modern contemporary styling with the innovative WaveStream™ technology to deliver exceptional performance and superior energy savings. Encounter's highly efficient LED system with advance optical design delivers an unparalleled combination of optimal light uniformity for enhanced visual comfort and superior efficiency for greater energy savings.

Encounter is compatible with all of today's popular ceiling systems and available in a variety of configurations for application versatility. Its perfect balance of form and function make it an ideal choice for commercial office spaces, schools, hospitals, retail and other indoor ambient applications.

SPECIFICATION FEATURES

Construction

Shallow 3-1/4" deep housing is extruded aluminum frame and injected molded composite end plates. End plates are securely attached with screws for strength and rigidity and the elimination of gaps. End plates have accessory grid-lock feature for safety and convenience. Four auxiliary fixture end suspension points are provided. Large access plate for supply connection.

Controls

The Encounter LED is Powered by Fifth Light, with a standard 0-10V continuous dimming driver that works with any 0-10V control/dimmer. Combine with energy saving products like occupancy sensors, daylighting controls and lighting relay panels to maximize energy savings. In addition, the Encounter can include a factory-installed integrated sensor system for occupancy and daylight dimming control and manual control from an optional handheld remote. Or, specify the Digital Addressable Lighting Interface (DALI) drivers, dimmable down to

1% with the HD option, for use with Fifth Light controls. See ordering information for details on all three options.

Electrical

Long-life LED system coupled with electrical driver to deliver optimal performance. LED's available in 3000K, 3500K, 4000K or 5000K with a typical CRI \leq 85. Projected life is 60,000 hours at 78% lumen output. Electronic drivers are available for 120-277V applications.

Emergency Battery Pack Option

Optional 120v-277v integral emergency battery pack is available in 7-watts or 14-watts to meet critical life-safety lighting requirements. The 90-minute batteries provide constant power to the LED system, ensuring code-compliance. A test switch/indicator button can be tested safely from the ground using a laser pointer, while the patented EZ Key prevents accidental discharge of the battery during construction. See ordering information for details.

Catalog #

Type

Project

Comments

Date

Prepared by

Driver Access

Drivers can be accessed via plenum.

Finish

Durable frame has high reflectance baked matte white enamel finish for luminous uniformity.

Optics

Precision formed optical assembly with positively retained high optical grade acrylic lenses provide a directed optical distribution using WaveStream technology.

Compliance

Components are UL recognized. Indoor luminaires are cULus and CSA listed for 25° C ambient environments, RoHS compliant, and comply with IESNA LM-79. LEDs comply with LM-80 standards. DesignLights Consortium® Qualified. Refer to www.designlights.org Qualified Products List under Family Models for details.

Warranty

Five year warranty.



**24EN
LED**

**2' X 4' TROFFER
LED MODULE**

Specification Grade Troffer



powered by
fifthlight
technology

CERTIFICATION DATA

cULus - 1598 and 2043**
Damp Location Listed
CSA
IC Rated
LM79/LM80 Compliant
ROHS Compliant
DesignLights Consortium® Qualified
NOM Compliant

*See Drywall Frame Kit Accessory in Ordering Information section.
**Fixture construction is suitable for use in Air-handling and plenum rated spaces in accordance with Section 300.22 (C) of the National Electrical Code, Section 4.3.11.2.6.5 of NFPA 90A and Section 602.2.1.4 of ICC.

LINEAR DISCONNECT

Safe and convenient means of disconnecting power



ADF130513
2015-09-09 15:40:27

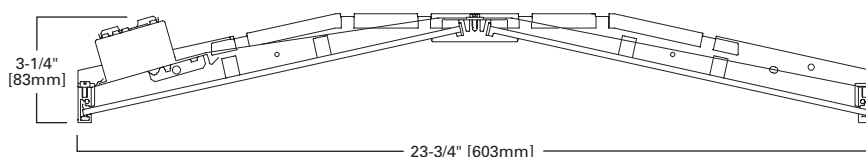

MOUNTING DATA

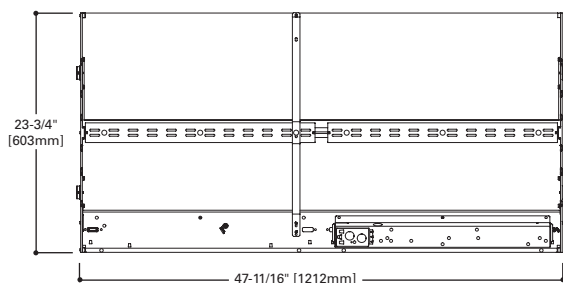

LAMP CONFIGURATIONS

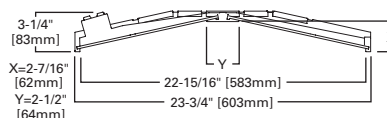

CEILING COMPATIBILITY

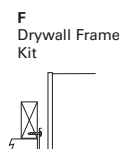
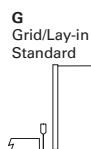

Ceiling Type
Exposed Grid
Concealed T
Slot Grid
Flange

Trim Type
G
G or T
G or T
*

PHOTOMETRICS

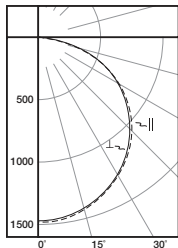

24EN-LD1-45-UNV-L835-CD1-U
 Electronic Driver
 Linear LED 3500K
 Spacing criterion:
 (||) 1.3 x mounting
 height, (⊥) 1.3 x
 mounting height
 Lumens: 4504
 Input Watts: 47.0W
 Efficacy: 96 LPW
 Test Report:
 24EN-LD1-44-UNV-
 L835-CD1-U.IES

Candlepower			
Angle	Along	45°	Across ⊥
0	1471	1471	1471
5	1473	1467	1467
10	1456	1448	1449
15	1425	1417	1417
20	1384	1374	1371
25	1332	1321	1315
30	1273	1260	1251
35	1204	1188	1179
40	1128	1111	1102
45	1046	1028	1022
50	954	936	932
55	854	834	832
60	744	722	728
65	625	601	617
70	494	480	472
75	357	347	302
80	219	195	210
85	99	96	97
90	0	0	0

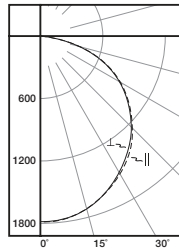

24EN-LD1-54-UNV-L835-CD1-U
 Electronic Driver
 Linear LED 3500K
 Spacing criterion:
 (||) 1.3 x mounting
 height, (⊥) 1.3 x
 mounting height
 Lumens: 5421
 Input Watts: 54.4W
 Efficacy: 100 LPW
 Test Report:
 24EN-LD1-54-UNV-
 L835-CD1-U.IES

Candlepower			
Angle	Along	45°	Across ⊥
0	1782	1782	1782
5	1781	1779	1780
10	1760	1758	1759
15	1724	1720	1720
20	1674	1669	1664
25	1614	1605	1595
30	1537	1526	1514
35	1455	1443	1424
40	1359	1346	1331
45	1260	1241	1231
50	1145	1130	1119
55	1023	1001	996
60	890	865	865
65	745	716	728
70	587	571	554
75	422	413	357
80	260	232	247
85	118	112	115
90	0	0	0

Coefficients of Utilization

rc rw RCR	Effective floor cavity reflectance 20%																	
	80%			70%			50%			30%			10%			0%		
	70	50	30	70	50	30	50	30	10	50	30	10	50	30	10	50	30	10
0	119	119	119	119	116	116	116	116	111	111	111	106	106	106	102	102	102	100
1	108	103	99	95	105	101	97	93	97	93	90	93	90	87	89	87	85	83
2	98	89	82	76	95	87	81	75	84	78	74	81	76	72	77	74	70	68
3	89	78	70	63	86	76	69	62	73	67	61	71	65	60	68	63	59	57
4	81	69	60	53	79	68	59	53	65	58	52	63	56	51	60	55	50	48
5	75	61	52	45	72	60	52	45	58	50	45	56	49	44	54	48	44	42
6	69	55	46	39	67	54	45	39	52	45	39	51	44	38	49	43	38	36
7	64	50	41	35	62	49	41	34	47	40	34	46	39	34	45	38	34	32
8	59	45	37	31	58	45	36	31	43	36	30	42	35	30	41	35	30	28
9	55	42	33	28	54	41	33	28	40	33	27	39	32	27	38	32	27	25
10	52	38	30	25	51	38	30	25	37	30	25	36	29	25	35	29	25	23

Coefficients of Utilization

rc rw RCR	Effective floor cavity reflectance 20%																	
	80%			70%			50%			30%			10%			0%		
	70	50	30	70	50	30	50	30	10	50	30	10	50	30	10	50	30	10
0	119	119	119	119	116	116	116	116	111	111	111	106	106	106	102	102	102	100
1	108	103	99	95	105	101	97	93	97	93	90	93	90	87	89	87	85	83
2	98	89	82	76	95	88	81	75	84	78	74	81	76	72	78	74	70	68
3	89	78	70	63	87	77	69	62	74	67	61	71	65	60	68	63	59	57
4	81	69	60	53	79	68	59	53	65	58	52	63	56	51	61	55	51	48
5	75	62	52	45	73	60	52	45	58	51	45	56	49	44	54	48	44	42
6	69	55	46	40	67	54	46	39	52	45	39	51	44	39	49	43	38	36
7	64	50	41	35	62	49	41	35	48	40	34	46	39	34	45	39	34	32
8	59	46	37	31	58	45	37	31	44	36	31	42	35	30	41	35	30	28
9	55	42	33	28	54	41	33	28	40	33	28	39	32	27	38	32	27	25
10	52	39	30	25	51	38	30	25	37	30	25	36	29	25	35	29	25	23

Zonal Lumen Summary

Zone	Lumens	%Fixture
0-30	1149	25.5
0-40	1893	42.0
0-60	3436	76.3
0-90	4504	100.0
0-180	4504	100.0

Luminance Data

Angle in Deg	Average 0-Deg cd/sm	Average 45-Deg cd/sm	Average 90-Deg cd/sm
45	1990	1955	1944
55	2003	1956	1951
65	1989	1913	1964
75	1855	1803	1569
85	1528	1481	1497

Zonal Lumen Summary

Zone	Lumens	%Fixture
0-30	1393	25.7
0-40	2295	42.3
0-60	4152	76.6
0-90	5421	100.0
0-180	5421	100.0

Luminance Data

Angle in Deg	Average 0-Deg cd/sm	Average 45-Deg cd/sm	Average 90-Deg cd/sm
45	2397	2361	2342
55	2399	2347	2336
65	2371	2279	2317
75	2193	2146	1855
85	1821	1728	1775

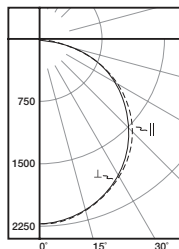

24EN-LD1-67-UNV-L835-CD1-U
 Electronic Driver
 Linear LED 3500K
 Spacing criterion:
 (||) 1.3 x mounting
 height, (⊥) 1.3 x
 mounting height
 Lumens: 6730
 Input Watts: 70.2W
 Efficacy: 96 LPW
 Test Report:
 24EN-LD1-66-UNV-
 L835-CD1-U.IES

Candlepower			
Angle	Along	45°	Across ⊥
0	2212	2212	2212
5	2219	2205	2205
10	2192	2178	2179
15	2149	2132	2132
20	2086	2068	2063
25	2009	1989	1976
30	1917	1893	1878
35	1814	1787	1768
40	1695	1667	1651
45	1570	1541	1526
50	1431	1400	1388
55	1280	1243	1230
60	1111	1071	1073
65	933	886	908
70	730	706	689
75	524	510	436
80	323	286	307
85	149	142	141
90	0	0	0

Coefficients of Utilization

rc rw RCR	Effective floor cavity reflectance 20%																	
	80%			70%			50%			30%			10%			0%		
	70	50	30	70	50	30	50	30	10	50	30	10	50	30	10	50	30	10
0	119	119	119	119	116	116	116	116	111	111	111	106	106	106	102	102	102	100
1	108	103	99	95	105	101	97	93	97	93	90	93	90	87	89	87	85	83
2	98	89	82	76	95	88	81	75	84	78	74	81	76	72	78	74	70	68
3	89	78	70	63	87	77	69	62	74	67	61	71	65	60	68	63	59	57
4	81	69	60	53	79	68	59	53	65	58	52	63	56	51	61	55	51	48
5	75	62	52	45	73	60	52	45	58	51	45	56	49	44	54	48	44	42
6	69	55	46	40	67	54	46	39	52	45	39	51	44	39	49	43	38	36
7	64	50	41	35	62	49	41	35	48	40	34	46	39	34	45	39	34	32
8	59	46	37	31	58	45	37	31	44	36	31	42	35	30	41	35	30	28
9	55	42	33	28	54	41	33	28	40	33	28	39	32	27	38	32	27	25
10	52	39	30	25	51	38	30	25	37	30	25	36	29	25	35	29	25	23

Zonal Lumen Summary

Zone	Lumens	%Fixture
0-30	1730	25.7
0-40	2849	42.3
0-60	5155	76.6
0-90	6730	100.0
0-180	6730	100.0

Luminance Data

Angle in Deg	Average 0-Deg cd/sm	Average 45-Deg cd/sm	Average 90-Deg cd/sm
45	2986	2931	2903
55	3002	2915	2884
65	2969	2820	2890
75	2723	2650	2266
85	2299	2191	2176

LUMEN MAINTENANCE

Ambient Temperature	TM-21 Lumen Maintenance (60,000 hours)	Theoretical L70 (Hours)
25°C	> 78%	> 92,000

ENERGY AND PERFORMANCE DATA BY CATALOG NUMBER

Stock or MTO*	Catalog Logic (Curved)	Delivered Lumens	Watts	Efficacy (LPW)
MTO	24EN-LD1-30-UNV-L830-CD1-U	2928	29.8	98
MTO	24EN-LD1-30-UNV-L835-CD1-U	3040	30.1	101
MTO	24EN-LD1-30-UNV-L840-CD1-U	3114	29.9	104
MTO	24EN-LD1-30-UNV-L850-CD1-U	3294	29.9	110
MTO	24EN-LD1-34-UNV-L830-CD1-U	3326	34.3	97
MTO	24EN-LD1-34-UNV-L835-CD1-U	3449	34.5	100
MTO	24EN-LD1-34-UNV-L840-CD1-U	3536	34.4	103
MTO	24EN-LD1-34-UNV-L850-CD1-U	3740	34.4	109
MTO	24EN-LD1-40-UNV-L830-CD1-U	3898	41.0	95
MTO	24EN-LD1-40-UNV-L835-CD1-U	4039	41.3	98
MTO	24EN-LD1-40-UNV-L840-CD1-U	4141	41.1	101
MTO	24EN-LD1-40-UNV-L850-CD1-U	4381	41.1	107
MTO	24EN-LD1-45-UNV-L830-CD1-U	4333	46.7	93
STOCK	24EN-LD1-45-UNV-L835-CD1-U	4504	47.0	96
STOCK	24EN-LD1-45-UNV-L840-CD1-U	4618	46.8	99
MTO	24EN-LD1-45-UNV-L850-CD1-U	4885	46.8	104
MTO	24EN-LD1-49-UNV-L830-CD1-U	4884	49.1	99
MTO	24EN-LD1-49-UNV-L835-CD1-U	4962	49.3	101
MTO	24EN-LD1-49-UNV-L840-CD1-U	5141	49.4	104
MTO	24EN-LD1-49-UNV-L850-CD1-U	5438	49.4	110
MTO	24EN-LD1-54-UNV-L830-CD1-U	5329	54.3	98
STOCK	24EN-LD1-54-UNV-L835-CD1-U	5421	54.4	100
STOCK	24EN-LD1-54-UNV-L840-CD1-U	5614	54.6	103
MTO	24EN-LD1-54-UNV-L850-CD1-U	5938	54.6	109
MTO	24EN-LD1-58-UNV-L830-CD1-U	5763	59.5	97
MTO	24EN-LD1-58-UNV-L835-CD1-U	5856	59.5	98
MTO	24EN-LD1-58-UNV-L840-CD1-U	6070	59.8	102
MTO	24EN-LD1-58-UNV-L850-CD1-U	6421	59.8	107
MTO	24EN-LD1-67-UNV-L830-CD1-U	6598	70.0	94
STOCK	24EN-LD1-67-UNV-L835-CD1-U	6730	70.2	96
STOCK	24EN-LD1-67-UNV-L840-CD1-U	6938	70.2	99
MTO	24EN-LD1-67-UNV-L850-CD1-U	7339	70.2	105
MTO	24EN-LD1-70-UNV-L830-CD1-U	6948	74.9	93
MTO	24EN-LD1-70-UNV-L835-CD1-U	7077	74.9	94
MTO	24EN-LD1-70-UNV-L840-CD1-U	7303	74.9	98
MTO	24EN-LD1-70-UNV-L850-CD1-U	7725	74.9	103
MTO	24EN-LD1-74-UNV-L830-CD1-U	7341	80.0	92
MTO	24EN-LD1-74-UNV-L835-CD1-U	7443	80.0	93
MTO	24EN-LD1-74-UNV-L840-CD1-U	7683	80.0	96
MTO	24EN-LD1-74-UNV-L850-CD1-U	8127	80.0	102

*Made to order (MTO) requires a typical four week lead time.

ORDERING INFORMATION

SAMPLE NUMBER: 24EN-LD1-67-UNV-L835-CD1-SVPD1-U

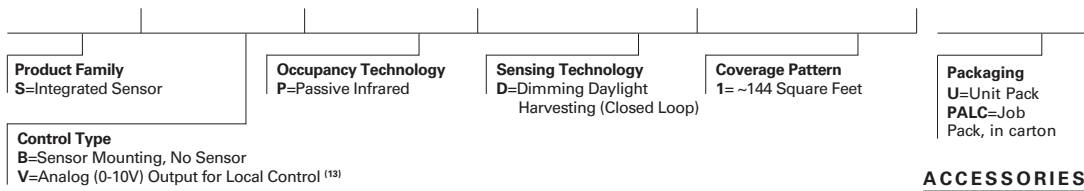
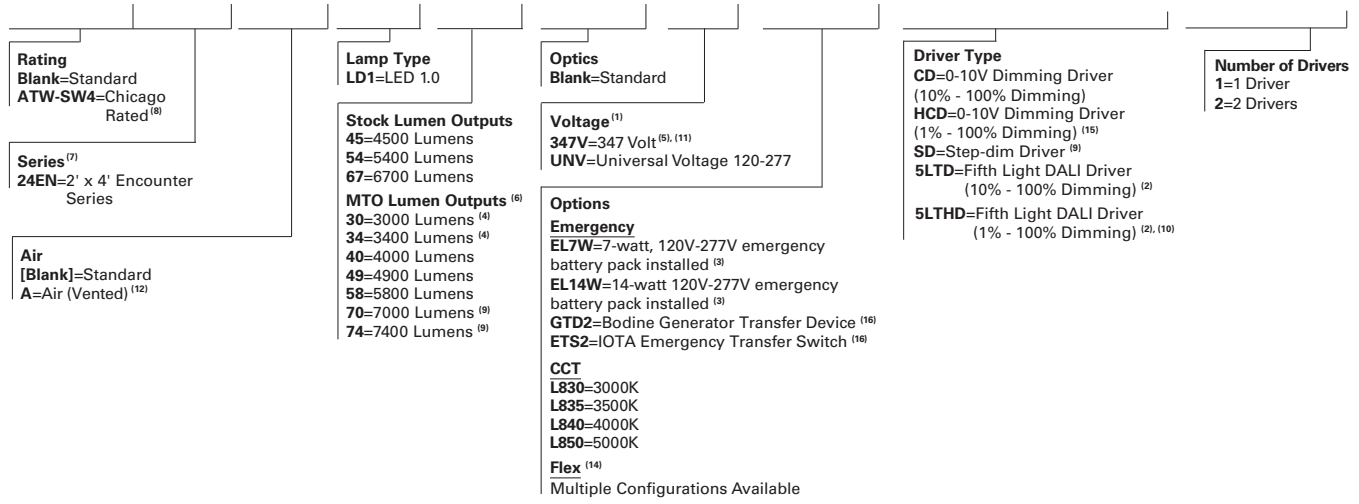

NOTES: ⁽¹⁾Products also available in non-US voltages and frequencies for international markets. ⁽²⁾Must be used in conjunction with a DALI control system. For complete DALI solutions by Fifth Light, visit www.eaton.com/lightingsystems ⁽³⁾With integral test switch/indicator/laser test. For approximate delivered lumens multiply the lumens per watt of the desired fixture by the wattage of the emergency battery pack (100 lm/W x 7=700 lumens). IES-format photometry for luminaire under emergency operation available. ⁽⁴⁾Step-dim driver not available with 3,000 and 3,400 lumen options. ⁽⁵⁾347V emergency option not available. ⁽⁶⁾Made-to-order (MTO) requires four week lead time. ⁽⁷⁾DesignLights Consortium™ Qualified and classified for DLC Standard (all lumen packages), refer to www.designlights.org for details. ⁽⁸⁾Chicago rated version does not allow for row mounting. ⁽⁹⁾Two drivers only required for 7000 and 7400 lumen options with step-dim driver. ⁽¹⁰⁾Two drivers required for 5LTHD option for 5800 lumens and up. ⁽¹¹⁾347V option not available with 7400 lumen package. ⁽¹²⁾Air version is vented but does not meet air handling requirements; a 6% reduction in delivered lumens is experienced with this option. ⁽¹³⁾Integral sensor works only with "CD" driver and is factory prewired to the driver for stand-alone control. ⁽¹⁴⁾Flex does not include dimming leads. Control leads provided by others. ⁽¹⁵⁾HCD driver option is not available with 6700, 7000 and 7400 lumen packages. ⁽¹⁶⁾Used to transfer fixture to secondary power source for life-safety operation. When used with a dimming fixture, two devices are required to ensure control is disabled while operating under emergency power.

Specifications & dimensions subject to change without notice. Consult your Eaton Representative for availability and ordering information.

ACCESSORIES

- T3A END E.O. BRACKET PARTS BAG (Standard with fixture)
- DF-24-W=2' x 4' Drywall Frame Kit
- SK-24-WS=2' x 4' Shallow Surface Mount Kit
- SK-24-WT=2' x 4' Tall Surface Mount Kit
- DF10P-C_=Decorator Dimmer, 0-10V
- SF10P-_=Decorator Slide Dimmer, 0-10V
- HHPRG-MS=Programming Remote for Integrated Sensor
- ISHH-02=Personal Control Remote for Integrated Sensor

SHIPPING DATA

Catalog No.	Wt.
24EN-LD1-45	28 lbs.
24EN-LD1-54	28 lbs.
24EN-LD1-67	28 lbs.



Eaton
1121 Highway 74 South
Peachtree City, GA 30269
P: 770-486-4800
www.eaton.com/lighting

Specifications and dimensions subject to change without notice.

INTEGRATED SENSOR

Description

This innovative luminaire-integrated sensor control system is optimized for code-compliant occupancy detection and daylight harvesting – all from within the foot print of Metalux’s award-winning recessed ambient luminaires.

No New Wires

An in-place fixture retrofit is all that’s needed to meet most energy codes in commercial spaces. The sensor system is factory wired to the luminaire, switching on or off based on occupancy, and dimming the light when enough daylight is available.

Sophisticated lighting control without commissioning

The luminaire-integrated sensor system offers out-of-the-box operation using thoughtful default settings.

Flexibility and Individual Control

When the application demands more, the sensor system has the option to make changes using a remote control. The remote allows changes from the default settings for occupancy, target light level, preset lighting levels, and more.

Cost-effective, Stand-alone Operation

With a single product to mount and a single electrical connection to make, the Metalux luminaire with an integrated sensor system saves money on the total installed cost when occupancy or daylight harvesting controls are needed. The integrated sensor system works stand-alone, without the need for additional switches and dimmers. When manual-on, manual dimming or other code-required control schemes are needed, please see the comprehensive offering of Greengate and Fifth Light solutions from Cooper Controls at www.coopercontrol.com.

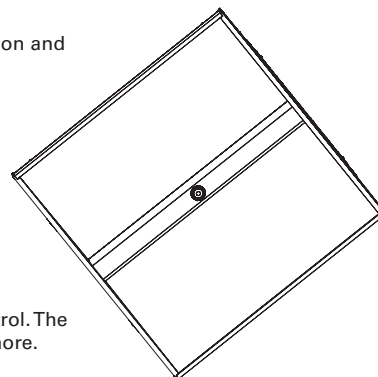

Metalux Integrated Sensor Sequence of Operation

The occupancy sensing portion of the sensor uses Passive Infrared (PIR) technology with Auto-on/Auto-off operation. The small lens in the center of the sensor directs the view of a passive infrared occupancy detector to sense occupants moving through the room. To trigger the light on, an occupant must cross at least two passive infrared beams. When motion in the coverage area ceases, the sensor logic concludes the room is unoccupied, and begins a count-down timer. By default, the timer is factory-set to 20 minutes, and can be adjusted to 5, 10, 15 and 20 minutes using the optional remote control, model number HHPRG-MS. Any motion detected during the count-down timer will cause the light to remain on and resets the timer. When motion is detected, a red LED will blink. In addition to the default on/off functionality, the sensor has an Energy Saver feature, where the light can be set to dim to a preset level after the sensor detects no occupancy for half of the count-down timer, when the timer is complete the lighting will change to the unoccupied setting. The Energy Saver feature works when the count-down timer is set to at least 15 minutes, and the preset level and feature are configured using the optional remote control. See the Sensor Programming Guide that comes with the HHPRG-MS remote for details on this feature. The sensitivity of the occupancy detection can be adjusted, using the HHPRG-MS remote. By default, the sensor operates at the full detection range shown on the coverage pattern diagram. Using the “LO” button on the HHPRG-MS remote, reduces the sensor detection range by 50%. Full coverage can be restored at any time by pressing the “HI” button on the remote. The red LED indicator will blink repeatedly to confirm any programming change.

The dimming daylight harvesting portion of the sensor uses a small photo sensor located next to the occupancy sensing lens. The sensor continuously measures the available light in the room, even when the fixture is turned off. This allows sensor to operate in one of three daylighting modes, where the artificial light from the paired Metalux luminaire can adjust the light based on the amount of ambient light from surrounding natural and artificial light sources. Since the sensor measures light from its luminaire along with other light sources, this sensor follows a closed-loop dimming daylight harvesting style. The first mode, Daytime, is active when the sensor detects light of at least 100 lux in the room. In Daytime mode, when the light is turned on after detecting occupancy, the sensor will begin balancing the luminaire light level relative to the total available light it measures. The default light balancing target in daytime mode is 500 lux. This level can be adjusted higher or lower using the optional HHPRG-MS remote, and pressing “SET” and then the “DO” (Daytime Occupied) button to store the new light level. Similarly, the Daytime Unoccupied, “DU” has a default of level of 0 lux, or off, but can be adjusted higher to prevent the lights from turning off completely when unoccupied. More details on this function are found in the Sensor Programming Guide for the HHPRG-MS remote.

The next two modes, Twilight and Nighttime, function in a similar way, allowing the artificial light to adjust to different levels based on the surroundings. While primarily for use in outdoor luminaires, these modes are available for use in areas with a wide range of natural light, including atriums, day lit stairwells, and rooms with large or continuous windows. The Twilight mode is active when the sensor detects 50-100 lux in the off position, and has a 300 lux default light balancing target. The Nighttime mode is active when the sensor detects less than 50 lux, and has a 250 lux default light balancing target. Like the Daytime mode, there are separate settings for Twilight Occupied (“TO”), Twilight Unoccupied (“TU”), Nighttime Occupied (“NO”) and Nighttime Unoccupied (“NU”) which can be adjusted and set using the optional HHPRG-MS remote.

In addition to programming the sensor, the optional HHPRG-MS remote can be used for personal control to adjust the lighting temporarily override the functions of the sensor temporarily. The remote has raise/lower buttons to adjust the light level for special tasks, as well as a power button to turn the lights on or off. Unless the SET button and another function is selected, any changes made using these buttons will revert to the programmed settings after the sensor has detected no occupancy for its programmed time out, and turned off the lighting. The next time the sensor detects occupancy, it will revert to its programmed settings for count-down timer and light balancing.

Coverage

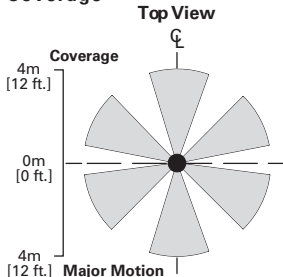

Side View

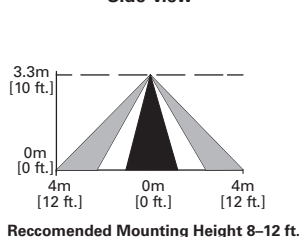

Optional Remote Control



HHPRG-MS Remote