

Wall-Mount Enclosures Type 4 Premier™ Series with Quarter-Turn Latches Data Sheet and Catalog Number



Application

- Houses electrical controls and instruments
- Intended for indoor or outdoor use
- Protects against circulating and windblown dust, falling dirt, dripping non-corrosive liquids, rain, splashing water and hose directed water

Standards

- UL 508A Listed, Type 4 and Type 12
- cUL Listed, Type 4 and Type 12
- Conforms to NEMA standard for Type 4 and Type 12
- Wall-mounting brackets required to maintain UL/CSA external mounting requirements

Finish

- Wash and phosphate undercoat
- ANSI 61 gray polyester powder finish
- Available with RAL7035 Light Gray textured paint. To order add an "LG" to the end of the part number as shown in the tables (pages 146 - 149)

Discount Schedule: C2

Subclass: TC0

Accessories

- Premier panels
- Security latch inserts
- NEMA panel adapters
- Mounting foot kits
- Depth adjustment brackets
- EIA/TIA rack mounting angles
- Print pockets
- Swing-out panels
- Padlockable or keyed handles
- See Accessories section, pages 154-159

Construction

- Enclosure and door are fabricated from code gauge steel (see tables, pages 146 - 149)
- All continuous welded seams are finished smooth
- Hardware kit provided contains grounding hardware, .312-18 flanged hex nuts for panel mounting, and sealing washers for body mounting holes

Body Construction

- Body flange trough design is formed around body opening to divert liquid contaminants away from door opening
- Reduced width flange design increases enclosure opening
- Ground stud provided on enclosure body and on door
- .312-18 collar studs are provided for mounting optional Premier panels
- Enclosure mounting holes in body provided for direct mounting or optional mounting feet

Door Construction

- Doors are secured to the body with concealed hinge design on one side and slotted quarter-turn flush latch(es) on the opposite side
- Doors are easily removed and interchangeable
- Door has a seamless poured in-place gasket
- Door opens 180° for easy access
- Window-door enclosures feature flush-mounted clear polycarbonate window

Notes: We can provide special sizes, finishes and other modifications. Consult the factory for your special requirements.

Type 4 Panel Enclosures

Wall-Mount Enclosures Type 4 Premier™ Series with Quarter-Turn Latches Catalog Number

Enclosure Catalog Number				Enclosure Size		Door/Body Gauge	Panel Catalog Number	Panel Size	
Solid Door		Window Door		A x B x C				H x W	
ANSI 61 Gray	RAL7035 Lt. Gray	ANSI 61 Gray	RAL7035 Lt. Gray	in.	mm			in.	mm
1084-SD	1084-SDLG	-	-	10 x 8 x 4	254 x 203 x 102	16/16	108P	8.00 x 6.00	203 x 152
1086-SD	1086-SDLG	-	-	10 x 8 x 6	254 x 203 x 152	16/16	108P	8.00 x 6.00	203 x 152
12106-SD	12106-SDLG	-	-	12 x 10 x 6	305 x 254 x 152	16/16	1210P	10.00 x 8.00	254 x 203
12126-SD	12126-SDLG	12126-SDW	12126-SDWLG	12 x 12 x 6	305 x 305 x 152	16/16	1212P	10.00 x 10.00	254 x 254
16126-SD	16126-SDLG	16126-SDW	16126-SDWLG	16 x 12 x 6	406 x 305 x 152	16/16	1612P	14.00 x 10.00	356 x 254
16166-SD	16166-SDLG	-	-	16 x 16 x 6	406 x 406 x 152	16/16	1616P	14.00 x 14.00	356 x 356
16206-SD	16206-SDLG	-	-	16 x 20 x 6	406 x 508 x 152	16/16	2016P	14.00 x 18.00	356 x 457
20166-SD	20166-SDLG	20166-SDW	20166-SDWLG	20 x 16 x 6	508 x 406 x 152	16/16	2016P	18.00 x 14.00	457 x 356
20206-SD	20206-SDLG	20206-SDW	20206-SDWLG	20 x 20 x 6	508 x 508 x 152	16/16	2020P	18.00 x 18.00	457 x 457
24166-SD	24166-SDLG	-	-	24 x 16 x 6	610 x 406 x 152	16/16	2416P	22.00 x 14.00	559 x 356
24206-SD	24206-SDLG	24206-SDW	-	24 x 20 x 6	610 x 508 x 152	16/16	2420P	22.00 x 18.00	559 x 457
24246-SD	24246-SDLG	24246-SDW	24246-SDWLG	24 x 24 x 6	610 x 610 x 152	14/16	2424P	22.00 x 22.00	559 x 559
16128-SD	16128-SDLG	16128-SDW	16128-SDWLG	16 x 12 x 8	406 x 305 x 203	16/16	1612P	14.00 x 10.00	356 x 254
16168-SD	16168-SDLG	-	-	16 x 16 x 8	406 x 406 x 203	16/16	1616P	14.00 x 14.00	356 x 356
16208-SD	16208-SDLG	-	-	16 x 20 x 8	406 x 508 x 203	16/16	2016P	14.00 x 18.00	356 x 457
20168-SD	20168-SDLG	20168-SDW	20168-SDWLG	20 x 16 x 8	508 x 406 x 203	16/16	2016P	18.00 x 14.00	457 x 356
20208-SD	20208-SDLG	20208-SDW	20208-SDWLG	20 x 20 x 8	508 x 508 x 203	16/16	2020P	18.00 x 18.00	457 x 457
20248-SD	20248-SDLG	-	-	20 x 24 x 8	508 x 610 x 203	16/16	2420P	18.00 x 22.00	457 x 559
24168-SD	24168-SDLG	-	-	24 x 16 x 8	610 x 406 x 203	16/16	2416P	22.00 x 14.00	559 x 356
24208-SD	24208-SDLG	24208-SDW	-	24 x 20 x 8	610 x 508 x 203	16/16	2420P	22.00 x 18.00	559 x 457
24248-SD	24248-SDLG	24248-SDW	24248-SDWLG	24 x 24 x 8	610 x 610 x 203	14/16	2424P	22.00 x 22.00	559 x 559
24308-SD	24308-SDLG	-	-	24 x 30 x 8	610 x 762 x 203	14/16	3024P	22.00 x 28.00	559 x 711
30208-SD	30208-SDLG	-	-	30 x 20 x 8	762 x 508 x 203	14/16	3020P	28.00 x 18.00	711 x 457
30248-SD	30248-SDLG	30248-SDW	30248-SDWLG	30 x 24 x 8	762 x 610 x 203	14/16	3024P	28.00 x 22.00	711 x 559
30308-SD	30308-SDLG	-	-	30 x 30 x 8	762 x 762 x 203	14/14	3030P	28.00 x 28.00	711 x 711
36248-SD	36248-SDLG	-	-	36 x 24 x 8	914 x 610 x 203	14/14	3624P	34.00 x 22.00	864 x 559
36308-SD	36308-SDLG	-	-	36 x 30 x 8	914 x 762 x 203	14/14	3630P	34.00 x 28.00	864 x 711
36368-SD	36368-SDLG	-	-	36 x 36 x 8	914 x 914 x 203	14/14	3636P	34.00 x 34.00	864 x 864
161210-SD	161210-SDLG	161210-SDW	-	16 x 12 x 10	406 x 305 x 254	16/16	1612P	14.00 x 10.00	356 x 254
161610-SD	161610-SDLG	-	-	16 x 16 x 10	406 x 406 x 254	16/16	1616P	14.00 x 14.00	356 x 356
162010-SD	162010-SDLG	-	-	16 x 20 x 10	406 x 508 x 254	16/16	2016P	14.00 x 18.00	356 x 457
201610-SD	201610-SDLG	201610-SDW	201610-SDWLG	20 x 16 x 10	508 x 406 x 254	16/16	2016P	18.00 x 14.00	457 x 356
202010-SD	202010-SDLG	202010-SDW	202010-SDWLG	20 x 20 x 10	508 x 508 x 254	16/16	2020P	18.00 x 18.00	457 x 457
202410-SD	202410-SDLG	-	-	20 x 24 x 10	508 x 610 x 254	16/16	2420P	18.00 x 22.00	457 x 559
241610-SD	241610-SDLG	-	-	24 x 16 x 10	610 x 406 x 254	16/16	2416P	22.00 x 14.00	559 x 356
242010-SD	242010-SDLG	242010-SDW	242010-SDWLG	24 x 20 x 10	610 x 508 x 254	16/16	2420P	22.00 x 18.00	559 x 457
242410-SD	242410-SDLG	242410-SDW	242410-SDWLG	24 x 24 x 10	610 x 610 x 254	14/16	2424P	22.00 x 22.00	559 x 559
243010-SD	243010-SDLG	-	-	24 x 30 x 10	610 x 762 x 254	14/16	3024P	22.00 x 28.00	559 x 711
302010-SD	302010-SDLG	-	-	30 x 20 x 10	762 x 508 x 254	14/16	3024P	28.00 x 18.00	711 x 457
302410-SD	302410-SDLG	302410-SDW	302410-SDWLG	30 x 24 x 10	762 x 610 x 254	14/16	3024P	28.00 x 22.00	711 x 559
303010-SD	303010-SDLG	-	-	30 x 30 x 10	762 x 762 x 254	14/14	3030P	28.00 x 28.00	711 x 711
362410-SD	362410-SDLG	-	-	36 x 24 x 10	914 x 610 x 254	14/14	3624P	34.00 x 22.00	864 x 559
363010-SD	363010-SDLG	-	-	36 x 30 x 10	914 x 762 x 254	14/14	3630P	34.00 x 28.00	864 x 711
423010-SD	-	-	-	42 x 30 x 10	1067 x 762 x 254	14/14	4230P	40.00 x 28.00	1016 x 711
363610-SD	363610-SDLG	-	-	36 x 36 x 10	914 x 914 x 254	14/14	3636P	34.00 x 34.00	864 x 864
423610-SD	423610-SDLG	-	-	42 x 36 x 10	1067 x 914 x 254	14/14	4236P	40.00 x 34.00	1016 x 864
482410-SD	482410-SDLG	-	-	48 x 24 x 10	1219 x 610 x 254	14/14	4824P	46.00 x 22.00	1168 x 559
483010-SD	-	-	-	48 x 30 x 10	1219 x 762 x 254	14/14	3048P	46.00 x 28.00	1168 x 711
483610-SD	483610-SDLG	-	-	48 x 36 x 10	1219 x 914 x 254	14/14	4836P	46.00 x 34.00	1168 x 864
603610-SD	603610-SDLG	-	-	60 x 36 x 10	1524 x 914 x 254	14/14	6036P	58.00 x 34.00	1473 x 86
202012-SD	202012-SDLG	202012-SDW	202012-SDWLG	20 x 20 x 12	508 x 508 x 305	16/16	2020P	18.00 x 18.00	457 x 457
242012-SD	242012-SDLG	242012-SDW	242012-SDWLG	24 x 20 x 12	610 x 508 x 305	16/16	2420P	22.00 x 18.00	559 x 457
242412-SD	242412-SDLG	242412-SDW	242412-SDWLG	24 x 24 x 12	610 x 610 x 305	14/16	2424P	22.00 x 22.00	559 x 559

Notes: Dimensions are in inches. Millimeters shown are for reference only. Data subject to change without notice.

Wall-Mount Enclosures Type 4 Premier™ Series with Quarter-Turn Latches Catalog Number cont. from page 146

Enclosure Catalog Number				Mounting		Window Size		Latch Quantity	J	
Solid Door		Window Door		D x E		F x G			in.	mm
ANSI 61 Gray	RAL7035 Lt. Gray	ANSI 61 Gray	RAL7035 Lt. Gray	in.	mm	in.	mm			
1084-SD	1084-SDLG	-	-	8.50 x 6.37	216 x 162	-	-	1	5.00	127
1086-SD	1086-SDLG	-	-	8.50 x 6.37	216 x 162	-	-	1	5.00	127
12106-SD	12106-SDLG	-	-	10.50 x 8.37	267 x 213	-	-	1	6.00	152
12126-SD	12126-SDLG	12126-SDW	12126-SDWLG	10.50 x 10.37	267 x 264	8.25 x 7.00	210 x 178	1	6.00	152
16126-SD	16126-SDLG	16126-SDW	16126-SDWLG	14.50 x 10.37	368 x 264	12.25 x 7.00	311 x 178	1	8.00	203
16166-SD	16166-SDLG	-	-	14.50 x 14.37	368 x 365	-	-	1	8.00	203
16206-SD	16206-SDLG	-	-	14.50 x 18.37	368 x 467	-	-	1	8.00	203
20166-SD	20166-SDLG	20166-SDW	20166-SDWLG	18.50 x 14.37	470 x 365	16.25 x 11.00	413 x 279	1	10.00	254
20206-SD	20206-SDLG	20206-SDW	20206-SDWLG	18.50 x 18.37	470 x 467	16.25 x 15.00	413 x 381	1	10.00	254
24166-SD	24166-SDLG	-	-	22.50 x 14.37	572 x 365	-	-	1	5.00	127
24206-SD	24206-SDLG	24206-SDW	-	22.50 x 18.37	572 x 467	20.25 x 15.00	514 x 381	1	5.00	127
24246-SD	24246-SDLG	24246-SDW	24246-SDWLG	22.50 x 22.37	572 x 568	20.25 x 17.62	514 x 448	1	5.00	127
16128-SD	16128-SDLG	16128-SDW	16128-SDWLG	14.50 x 10.37	368 x 264	12.25x7.00	311x178	1	8.00	203
16168-SD	16168-SDLG	-	-	14.50 x 14.37	368 x 365	-	-	1	8.00	203
16208-SD	16208-SDLG	-	-	14.50 x 18.37	368 x 467	-	-	1	8.00	202
20168-SD	20168-SDLG	20168-SDW	20168-SDWLG	18.50 x 14.37	470 x 365	16.25 x 11.00	413 x 279	1	10.00	254
20208-SD	20208-SDLG	20208-SDW	20208-SDWLG	18.50 x 18.37	470 x 467	16.25 x 15.00	413 x 381	1	10.00	254
20248-SD	20248-SDLG	-	-	18.50 x 22.37	470 x 568	-	-	1	10.00	254
24168-SD	24168-SDLG	-	-	22.50 x 14.37	572 x 365	-	-	1	5.00	127
24208-SD	24208-SDLG	24208-SDW	-	22.50 x 18.37	572 x 467	20.25 x 15.00	514 x 381	1	5.00	127
24248-SD	24248-SDLG	24248-SDW	24248-SDWLG	22.50 x 22.37	572 x 568	20.25 x 17.62	514 x 448	2	5.00	127
24308-SD	24308-SDLG	-	-	22.50 x 28.37	572 x 721	-	-	2	5.00	127
30208-SD	30208-SDLG	-	-	28.50 x 18.37	724 x 467	-	-	2	5.00	127
30248-SD	30248-SDLG	30248-SDW	30248-SDWLG	28.50 x 22.37	724 x 568	26.25 x 17.62	667 x 448	2	5.00	127
30308-SD	30308-SDLG	-	-	28.50 x 28.37	724 x 721	-	-	2	5.00	127
36248-SD	36248-SDLG	-	-	34.50 x 22.37	876 x 568	-	-	2	5.00	127
36308-SD	36308-SDLG	-	-	34.50 x 28.37	876 x 721	-	-	2	5.00	127
36368-SD	36368-SDLG	-	-	34.50 x 34.37	876 x 873	-	-	2	5.00	127
161210-SD	161210-SDLG	161210-SDW	-	14.50 x 10.37	368 x 264	12.25 x 7.00	311 x 178	1	8.00	203
161610-SD	161610-SDLG	-	-	14.50 x 14.37	368 x 365	-	-	1	8.00	203
162010-SD	162010-SDLG	-	-	14.50 x 18.37	368 x 467	-	-	1	8.00	203
201610-SD	201610-SDLG	201610-SDW	201610-SDWLG	18.50 x 14.37	470 x 365	16.25 x 11.00	413 x 279	1	10.00	254
202010-SD	202010-SDLG	202010-SDW	202010-SDWLG	18.50 x 18.37	470 x 467	16.25 x 15.00	413 x 381	1	10.00	254
202410-SD	202410-SDLG	-	-	18.50 x 22.37	470 x 568	-	-	1	10.00	254
241610-SD	241610-SDLG	-	-	22.50 x 14.37	572 x 365	-	-	1	5.00	127
242010-SD	242010-SDLG	242010-SDW	242010-SDWLG	22.50 x 18.37	572 x 467	20.25 x 15.00	514 x 381	1	5.00	127
242410-SD	242410-SDLG	242410-SDW	242410-SDWLG	22.50 x 22.37	572 x 568	20.25 x 17.62	514 x 448	2	5.00	127
243010-SD	243010-SDLG	-	-	22.50 x 28.37	572 x 721	-	-	2	5.00	127
302010-SD	302010-SDLG	-	-	28.50 x 18.37	724 x 467	-	-	2	5.00	127
302410-SD	302410-SDLG	302410-SDW	302410-SDWLG	28.50 x 22.37	724 x 568	26.25 x 17.62	667 x 448	2	5.00	127
303010-SD	303010-SDLG	-	-	28.50 x 28.37	724 x 721	-	-	2	5.00	127
362410-SD	362410-SDLG	-	-	34.50 x 22.37	876 x 568	-	-	2	5.00	127
363010-SD	363010-SDLG	-	-	34.50 x 28.37	876 x 721	-	-	2	5.00	127
423010-SD	-	-	-	40.50 x 28.37	1029 x 721	-	-	3	5.00	127
363610-SD	363610-SDLG	-	-	34.50 x 34.37	876 x 873	-	-	2	5.00	127
423610-SD	423610-SDLG	-	-	40.50 x 34.37	1029 x 873	-	-	3	5.00	127
482410-SD	482410-SDLG	-	-	46.50 x 22.37	1181 x 568	-	-	3	5.00	127
483010-SD	-	-	-	46.50 x 28.37	1181 x 721	-	-	3	5.00	127
483610-SD	483610-SDLG	-	-	46.50 x 34.37	1181 x 873	-	-	3	5.00	127
603610-SD	603610-SDLG	-	-	58.50 x 34.37	1486 x 873	-	-	3	5.00	127
202012-SD	202012-SDLG	202012-SDW	202012-SDWLG	18.50 x 18.37	470 x 467	16.25 x 15.00	413 x 381	1	10.00	254
242012-SD	242012-SDLG	242012-SDW	242012-SDWLG	22.50 x 18.37	572 x 467	20.25 x 15.00	514 x 381	1	5.00	127
242412-SD	242412-SDLG	242412-SDW	242412-SDWLG	22.50 x 22.37	572 x 568	20.25 x 17.62	514 x 448	2	5.00	127

Notes: Dimensions are in inches. Millimeters shown are for reference only. Data subject to change without notice.

Type 4 Panel Enclosures

Type 4 Panel Enclosures

Wall-Mount Enclosures Type 4 Premier™ Series with Quarter-Turn Latches Catalog Number

Enclosure Catalog Number				Enclosure Size		Door/Body Gauge	Panel Catalog Number	Panel Size	
Solid Door		Window Door		A x B x C				H x W	
ANSI 61 Gray	RAL7035 Lt. Gray	ANSI 61 Gray	RAL7035 Lt. Gray	in.	mm			in.	mm
302412-SD	302412-SDLG	302412-SDW	302412-SDWLG	30 x 24 x 12	762 x 610 x 305	14/16	3024P	28.00 x 22.00	711 x 559
303012-SD	303012-SDLG	-	-	30 x 30 x 12	762 x 762 x 305	14/14	3030P	28.00 x 28.00	711 x 711
362412-SD	362412-SDLG	-	-	36 x 24 x 12	914 x 610 x 305	14/14	3624P	34.00 x 22.00	864 x 559
363012-SD	363012-SDLG	-	-	36 x 30 x 12	914 x 762 x 305	14/14	3630P	34.00 x 28.00	864 x 711
423012-SD	423012-SDLG	-	-	42 x 30 x 12	1067 x 762 x 305	14/14	4230P	40.00 x 28.00	1016 x 711
363612-SD	363612-SDLG	-	-	36 x 36 x 12	914 x 914 x 305	14/14	3636P	34.00 x 34.00	864 x 864
423612-SD	423612-SDLG	-	-	42 x 36 x 12	1067 x 914 x 305	14/14	4236P	40.00 x 34.00	1016 x 864
482412-SD	482412-SDLG	-	-	48 x 24 x 12	1219 x 610 x 305	14/14	4824P	46.00 x 22.00	1168 x 559
483612-SD	483612-SDLG	-	-	48 x 36 x 12	1219 x 914 x 305	14/14	4836P	46.00 x 34.00	1168 x 864
603612-SD	603612-SDLG	-	-	60 x 36 x 12	1524 x 914 x 305	14/14	6036P	58.00 x 34.00	1473 x 864
242016-SD	-	-	-	24 x 20 x 16	610 x 508 x 406	14/14	2420P	22.00 x 18.00	559 x 457
242416-SD	242416-SDLG	242416-SDW	242416-SDWLG	24 x 24 x 16	610 x 610 x 406	14/14	2424P	22.00 x 22.00	559 x 559
302416-SD	-	-	-	30 x 24 x 16	762 x 610 x 406	14/14	3024P	28.00 x 22.00	711 x 559
362416-SD	-	-	-	36 x 24 x 16	914 x 610 x 406	14/14	3624P	34.00 x 22.00	864 x 559
363016-SD	363016-SDLG	-	-	36 x 30 x 16	914 x 762 x 406	14/14	3630P	34.00 x 28.00	864 x 711
423616-SD	-	-	-	42 x 36 x 16	1067 x 914 x 406	14/14	4236P	40.00 x 34.00	1016 x 864
483616-SD	483616-SDLG	-	-	48 x 36 x 16	1219 x 914 x 406	14/14	4836P	46.00 x 34.00	1168 x 864
603616-SD	-	-	-	60 x 36 x 16	1524 x 914 x 406	14/14	6036P	58.00 x 34.00	1473 x 864
242420-SD	242420-SDLG	242420-SDW	242420-SDWLG	24 x 24 x 20	610 x 610 x 508	14/14	2424P	22.00 x 22.00	559 x 559
302420-SD	302420-SDLG	302420-SDW	302420-SDWLG	30 x 24 x 20	762 x 610 x 508	14/14	3024P	28.00 x 22.00	711 x 559
363020-SD	363020-SDLG	-	-	36 x 30 x 20	914 x 762 x 508	14/14	3630P	34.00 x 28.00	864 x 711
483620-SD	-	-	-	48 x 36 x 20	1219 x 914 x 508	14/14	4836P	46.00 x 34.00	1168 x 864
603620-SD	-	-	-	60 x 36 x 20	1524 x 914 x 508	14/14	6036P	58.00 x 34.00	1473 x 864

Type 4 Panel Enclosures

Illustration Without Window

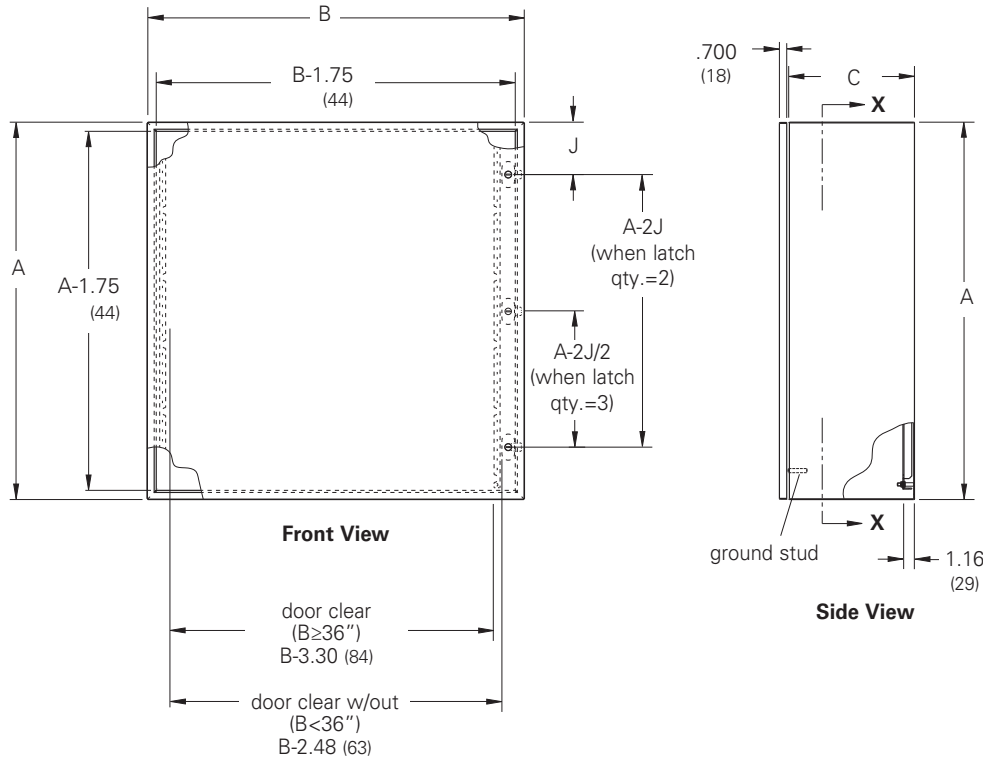

Notes: Dimensions are in inches. Millimeters shown are for reference only. Data subject to change without notice.

Wall-Mount Enclosures Type 4 Premier™ Series with Quarter-Turn Latches

Catalog Number cont. from page 148

Enclosure Catalog Number				Mounting		Window Size		Latch Quantity	J	
Solid Door		Window Door		D x E		F x G			in.	mm
ANSI 61 Gray	RAL7035 Lt. Gray	ANSI 61 Gray	RAL7035 Lt. Gray	in.	mm	in.	mm			
302412-SD	302412-SDLG	302412-SDW	302412-SDWLG	28.50 x 22.37	724 x 568	26.25 x 17.62	667 x 448	2	5.00	127
303012-SD	303012-SDLG	-	-	28.50 x 28.37	724 x 721	-	-	2	5.00	127
362412-SD	362412-SDLG	-	-	34.50 x 22.37	876 x 568	-	-	2	5.00	127
363012-SD	363012-SDLG	-	-	34.50 x 28.37	876 x 721	-	-	2	5.00	127
423012-SD	423012-SDLG	-	-	40.50 x 28.37	1029 x 721	-	-	3	5.00	127
363612-SD	363612-SDLG	-	-	34.50 x 34.37	876 x 873	-	-	2	5.00	127
423612-SD	423612-SDLG	-	-	40.50 x 34.37	1029 x 873	-	-	3	5.00	127
482412-SD	482412-SDLG	-	-	46.50 x 22.37	1181 x 568	-	-	3	5.00	127
483612-SD	483612-SDLG	-	-	46.50 x 34.37	1181 x 873	-	-	3	5.00	127
603612-SD	603612-SDLG	-	-	58.50 x 34.37	1486 x 873	-	-	3	5.00	127
242016-SD	-	-	-	22.50 x 18.37	572 x 467	-	-	2	5.00	127
242416-SD	242416-SDLG	242416-SDW	242416-SDWLG	22.50 x 22.37	572 x 568	20.25 x 17.62	514 x 448	2	5.00	127
302416-SD	-	-	-	28.50 x 22.37	725 x 568	-	-	2	5.00	127
362416-SD	-	-	-	34.50 x 22.37	876 x 568	-	-	2	5.00	127
363016-SD	363016-SDLG	-	-	34.50 x 28.37	876 x 721	-	-	2	5.00	127
423616-SD	-	-	-	40.50 x 34.37	1029 x 873	-	-	3	5.00	127
483616-SD	483616-SDLG	-	-	46.50 x 34.37	1181 x 873	-	-	3	5.00	127
603616-SD	-	-	-	58.50 x 34.37	1486 x 873	-	-	3	5.00	127
242420-SD	242420-SDLG	242420-SDW	242420-SDWLG	22.50 x 22.37	572 x 568	20.25 x 17.62	514 x 448	2	5.00	127
302420-SD	302420-SDLG	302420-SDW	302420-SDWLG	28.50 x 22.37	724 x 568	26.25 x 17.62	667 x 448	2	5.00	127
363020-SD	363020-SDLG	-	-	34.50 x 28.37	876 x 721	-	-	2	5.00	127
483620-SD	-	-	-	46.50 x 34.37	1181 x 873	-	-	3	5.00	127
603620-SD	-	-	-	58.50 x 34.37	1486 x 873	-	-	3	5.00	127

Illustration With Window

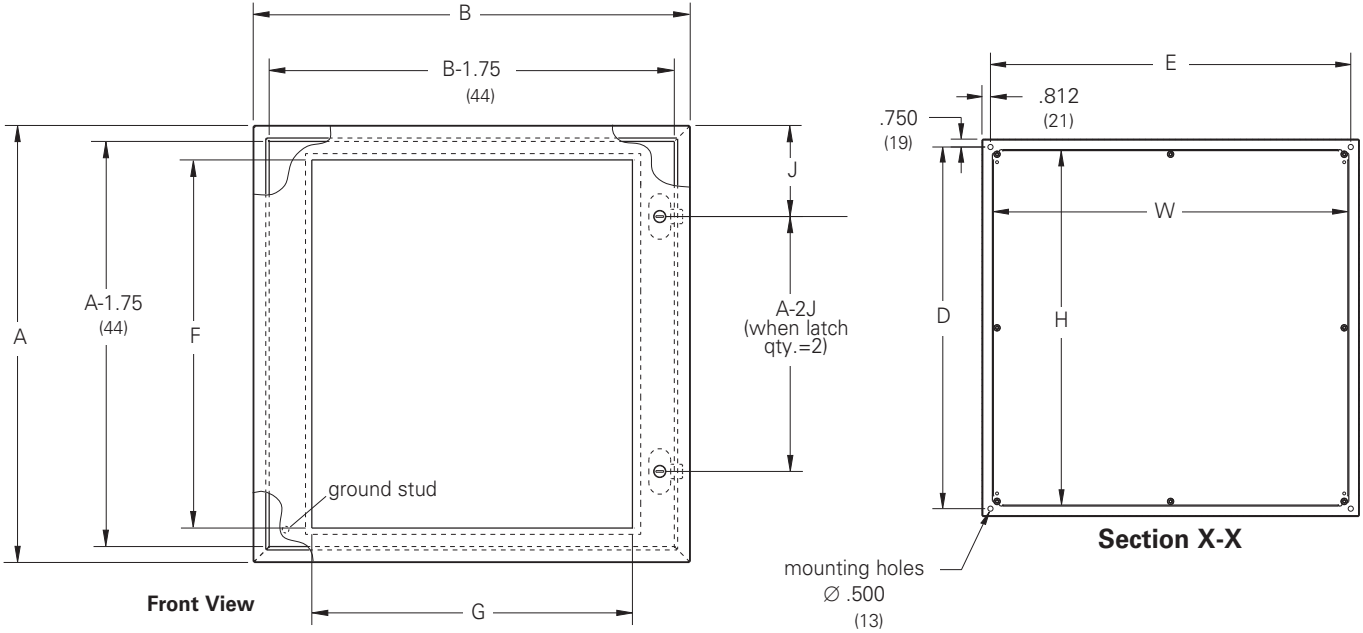

Notes: Dimensions are in inches. Millimeters shown are for reference only. Data subject to change without notice.

Type 4 Panel Enclosures

Wall-Mount Enclosures Type 4 Premier™ Series with Quarter-Turn Latches Data Sheet and Catalog Number



Application

- Houses electrical controls and instruments
- Intended for indoor or outdoor use
- Protects against circulating and windblown dust, falling dirt, dripping non-corrosive liquids, rain, splashing water and hose directed water

Standards

- UL 508A Listed, Type 4 and Type 12
- cUL Listed, Type 4 and Type 12
- Conforms to NEMA standard for Type 4 and Type 12
- Wall-mounting brackets required to maintain UL/CSA external mounting requirements

Finish

- Wash and phosphate undercoat
- ANSI 61 gray polyester powder finish
- Available with RAL7035 Light Gray textured paint. To order add an "LG" to the end of the part number as shown in the tables (pages 146 - 149)

Discount Schedule: C2

Subclass: TC0

Accessories

- Premier panels
- Security latch inserts
- NEMA panel adapters
- Mounting foot kits
- Depth adjustment brackets
- EIA/TIA rack mounting angles
- Print pockets
- Swing-out panels
- Padlockable or keyed handles
- See Accessories section, pages 154-159

Construction

- Enclosure and door are fabricated from code gauge steel (see tables, pages 146 - 149)
- All continuous welded seams are finished smooth
- Hardware kit provided contains grounding hardware, .312-18 flanged hex nuts for panel mounting, and sealing washers for body mounting holes

Body Construction

- Body flange trough design is formed around body opening to divert liquid contaminants away from door opening
- Reduced width flange design increases enclosure opening
- Ground stud provided on enclosure body and on door
- .312-18 collar studs are provided for mounting optional Premier panels
- Enclosure mounting holes in body provided for direct mounting or optional mounting feet

Door Construction

- Doors are secured to the body with concealed hinge design on one side and slotted quarter-turn flush latch(es) on the opposite side
- Doors are easily removed and interchangeable
- Door has a seamless poured in-place gasket
- Door opens 180° for easy access
- Window-door enclosures feature flush-mounted clear polycarbonate window

Notes: We can provide special sizes, finishes and other modifications. Consult the factory for your special requirements.

Type 4 Panel Enclosures

Wall-Mount Enclosures Type 4 Premier™ Series with Quarter-Turn Latches Catalog Number

Enclosure Catalog Number				Enclosure Size		Door/Body Gauge	Panel Catalog Number	Panel Size	
Solid Door		Window Door		A x B x C				H x W	
ANSI 61 Gray	RAL7035 Lt. Gray	ANSI 61 Gray	RAL7035 Lt. Gray	in.	mm			in.	mm
1084-SD	1084-SDLG	-	-	10 x 8 x 4	254 x 203 x 102	16/16	108P	8.00 x 6.00	203 x 152
1086-SD	1086-SDLG	-	-	10 x 8 x 6	254 x 203 x 152	16/16	108P	8.00 x 6.00	203 x 152
12106-SD	12106-SDLG	-	-	12 x 10 x 6	305 x 254 x 152	16/16	1210P	10.00 x 8.00	254 x 203
12126-SD	12126-SDLG	12126-SDW	12126-SDWLG	12 x 12 x 6	305 x 305 x 152	16/16	1212P	10.00 x 10.00	254 x 254
16126-SD	16126-SDLG	16126-SDW	16126-SDWLG	16 x 12 x 6	406 x 305 x 152	16/16	1612P	14.00 x 10.00	356 x 254
16166-SD	16166-SDLG	-	-	16 x 16 x 6	406 x 406 x 152	16/16	1616P	14.00 x 14.00	356 x 356
16206-SD	16206-SDLG	-	-	16 x 20 x 6	406 x 508 x 152	16/16	2016P	14.00 x 18.00	356 x 457
20166-SD	20166-SDLG	20166-SDW	20166-SDWLG	20 x 16 x 6	508 x 406 x 152	16/16	2016P	18.00 x 14.00	457 x 356
20206-SD	20206-SDLG	20206-SDW	20206-SDWLG	20 x 20 x 6	508 x 508 x 152	16/16	2020P	18.00 x 18.00	457 x 457
24166-SD	24166-SDLG	-	-	24 x 16 x 6	610 x 406 x 152	16/16	2416P	22.00 x 14.00	559 x 356
24206-SD	24206-SDLG	24206-SDW	-	24 x 20 x 6	610 x 508 x 152	16/16	2420P	22.00 x 18.00	559 x 457
24246-SD	24246-SDLG	24246-SDW	24246-SDWLG	24 x 24 x 6	610 x 610 x 152	14/16	2424P	22.00 x 22.00	559 x 559
16128-SD	16128-SDLG	16128-SDW	16128-SDWLG	16 x 12 x 8	406 x 305 x 203	16/16	1612P	14.00 x 10.00	356 x 254
16168-SD	16168-SDLG	-	-	16 x 16 x 8	406 x 406 x 203	16/16	1616P	14.00 x 14.00	356 x 356
16208-SD	16208-SDLG	-	-	16 x 20 x 8	406 x 508 x 203	16/16	2016P	14.00 x 18.00	356 x 457
20168-SD	20168-SDLG	20168-SDW	20168-SDWLG	20 x 16 x 8	508 x 406 x 203	16/16	2016P	18.00 x 14.00	457 x 356
20208-SD	20208-SDLG	20208-SDW	20208-SDWLG	20 x 20 x 8	508 x 508 x 203	16/16	2020P	18.00 x 18.00	457 x 457
20248-SD	20248-SDLG	-	-	20 x 24 x 8	508 x 610 x 203	16/16	2420P	18.00 x 22.00	457 x 559
24168-SD	24168-SDLG	-	-	24 x 16 x 8	610 x 406 x 203	16/16	2416P	22.00 x 14.00	559 x 356
24208-SD	24208-SDLG	24208-SDW	-	24 x 20 x 8	610 x 508 x 203	16/16	2420P	22.00 x 18.00	559 x 457
24248-SD	24248-SDLG	24248-SDW	24248-SDWLG	24 x 24 x 8	610 x 610 x 203	14/16	2424P	22.00 x 22.00	559 x 559
24308-SD	24308-SDLG	-	-	24 x 30 x 8	610 x 762 x 203	14/16	3024P	22.00 x 28.00	559 x 711
30208-SD	30208-SDLG	-	-	30 x 20 x 8	762 x 508 x 203	14/16	3020P	28.00 x 18.00	711 x 457
30248-SD	30248-SDLG	30248-SDW	30248-SDWLG	30 x 24 x 8	762 x 610 x 203	14/16	3024P	28.00 x 22.00	711 x 559
30308-SD	30308-SDLG	-	-	30 x 30 x 8	762 x 762 x 203	14/14	3030P	28.00 x 28.00	711 x 711
36248-SD	36248-SDLG	-	-	36 x 24 x 8	914 x 610 x 203	14/14	3624P	34.00 x 22.00	864 x 559
36308-SD	36308-SDLG	-	-	36 x 30 x 8	914 x 762 x 203	14/14	3630P	34.00 x 28.00	864 x 711
36368-SD	36368-SDLG	-	-	36 x 36 x 8	914 x 914 x 203	14/14	3636P	34.00 x 34.00	864 x 864
161210-SD	161210-SDLG	161210-SDW	-	16 x 12 x 10	406 x 305 x 254	16/16	1612P	14.00 x 10.00	356 x 254
161610-SD	161610-SDLG	-	-	16 x 16 x 10	406 x 406 x 254	16/16	1616P	14.00 x 14.00	356 x 356
162010-SD	162010-SDLG	-	-	16 x 20 x 10	406 x 508 x 254	16/16	2016P	14.00 x 18.00	356 x 457
201610-SD	201610-SDLG	201610-SDW	201610-SDWLG	20 x 16 x 10	508 x 406 x 254	16/16	2016P	18.00 x 14.00	457 x 356
202010-SD	202010-SDLG	202010-SDW	202010-SDWLG	20 x 20 x 10	508 x 508 x 254	16/16	2020P	18.00 x 18.00	457 x 457
202410-SD	202410-SDLG	-	-	20 x 24 x 10	508 x 610 x 254	16/16	2420P	18.00 x 22.00	457 x 559
241610-SD	241610-SDLG	-	-	24 x 16 x 10	610 x 406 x 254	16/16	2416P	22.00 x 14.00	559 x 356
242010-SD	242010-SDLG	242010-SDW	242010-SDWLG	24 x 20 x 10	610 x 508 x 254	16/16	2420P	22.00 x 18.00	559 x 457
242410-SD	242410-SDLG	242410-SDW	242410-SDWLG	24 x 24 x 10	610 x 610 x 254	14/16	2424P	22.00 x 22.00	559 x 559
243010-SD	243010-SDLG	-	-	24 x 30 x 10	610 x 762 x 254	14/16	3024P	22.00 x 28.00	559 x 711
302010-SD	302010-SDLG	-	-	30 x 20 x 10	762 x 508 x 254	14/16	3024P	28.00 x 18.00	711 x 457
302410-SD	302410-SDLG	302410-SDW	302410-SDWLG	30 x 24 x 10	762 x 610 x 254	14/16	3024P	28.00 x 22.00	711 x 559
303010-SD	303010-SDLG	-	-	30 x 30 x 10	762 x 762 x 254	14/14	3030P	28.00 x 28.00	711 x 711
362410-SD	362410-SDLG	-	-	36 x 24 x 10	914 x 610 x 254	14/14	3624P	34.00 x 22.00	864 x 559
363010-SD	363010-SDLG	-	-	36 x 30 x 10	914 x 762 x 254	14/14	3630P	34.00 x 28.00	864 x 711
423010-SD	-	-	-	42 x 30 x 10	1067 x 762 x 254	14/14	4230P	40.00 x 28.00	1016 x 711
363610-SD	363610-SDLG	-	-	36 x 36 x 10	914 x 914 x 254	14/14	3636P	34.00 x 34.00	864 x 864
423610-SD	423610-SDLG	-	-	42 x 36 x 10	1067 x 914 x 254	14/14	4236P	40.00 x 34.00	1016 x 864
482410-SD	482410-SDLG	-	-	48 x 24 x 10	1219 x 610 x 254	14/14	4824P	46.00 x 22.00	1168 x 559
483010-SD	-	-	-	48 x 30 x 10	1219 x 762 x 254	14/14	3048P	46.00 x 28.00	1168 x 711
483610-SD	483610-SDLG	-	-	48 x 36 x 10	1219 x 914 x 254	14/14	4836P	46.00 x 34.00	1168 x 864
603610-SD	603610-SDLG	-	-	60 x 36 x 10	1524 x 914 x 254	14/14	6036P	58.00 x 34.00	1473 x 86
202012-SD	202012-SDLG	202012-SDW	202012-SDWLG	20 x 20 x 12	508 x 508 x 305	16/16	2020P	18.00 x 18.00	457 x 457
242012-SD	242012-SDLG	242012-SDW	242012-SDWLG	24 x 20 x 12	610 x 508 x 305	16/16	2420P	22.00 x 18.00	559 x 457
242412-SD	242412-SDLG	242412-SDW	242412-SDWLG	24 x 24 x 12	610 x 610 x 305	14/16	2424P	22.00 x 22.00	559 x 559

Notes: Dimensions are in inches. Millimeters shown are for reference only. Data subject to change without notice.

Wall-Mount Enclosures Type 4 Premier™ Series with Quarter-Turn Latches Catalog Number cont. from page 146

Enclosure Catalog Number				Mounting		Window Size		Latch Quantity	J	
Solid Door		Window Door		D x E		F x G			in.	mm
ANSI 61 Gray	RAL7035 Lt. Gray	ANSI 61 Gray	RAL7035 Lt. Gray	in.	mm	in.	mm			
1084-SD	1084-SDLG	-	-	8.50 x 6.37	216 x 162	-	-	1	5.00	127
1086-SD	1086-SDLG	-	-	8.50 x 6.37	216 x 162	-	-	1	5.00	127
12106-SD	12106-SDLG	-	-	10.50 x 8.37	267 x 213	-	-	1	6.00	152
12126-SD	12126-SDLG	12126-SDW	12126-SDWLG	10.50 x 10.37	267 x 264	8.25 x 7.00	210 x 178	1	6.00	152
16126-SD	16126-SDLG	16126-SDW	16126-SDWLG	14.50 x 10.37	368 x 264	12.25 x 7.00	311 x 178	1	8.00	203
16166-SD	16166-SDLG	-	-	14.50 x 14.37	368 x 365	-	-	1	8.00	203
16206-SD	16206-SDLG	-	-	14.50 x 18.37	368 x 467	-	-	1	8.00	203
20166-SD	20166-SDLG	20166-SDW	20166-SDWLG	18.50 x 14.37	470 x 365	16.25 x 11.00	413 x 279	1	10.00	254
20206-SD	20206-SDLG	20206-SDW	20206-SDWLG	18.50 x 18.37	470 x 467	16.25 x 15.00	413 x 381	1	10.00	254
24166-SD	24166-SDLG	-	-	22.50 x 14.37	572 x 365	-	-	1	5.00	127
24206-SD	24206-SDLG	24206-SDW	-	22.50 x 18.37	572 x 467	20.25 x 15.00	514 x 381	1	5.00	127
24246-SD	24246-SDLG	24246-SDW	24246-SDWLG	22.50 x 22.37	572 x 568	20.25 x 17.62	514 x 448	1	5.00	127
16128-SD	16128-SDLG	16128-SDW	16128-SDWLG	14.50 x 10.37	368 x 264	12.25x7.00	311x178	1	8.00	203
16168-SD	16168-SDLG	-	-	14.50 x 14.37	368 x 365	-	-	1	8.00	203
16208-SD	16208-SDLG	-	-	14.50 x 18.37	368 x 467	-	-	1	8.00	202
20168-SD	20168-SDLG	20168-SDW	20168-SDWLG	18.50 x 14.37	470 x 365	16.25 x 11.00	413 x 279	1	10.00	254
20208-SD	20208-SDLG	20208-SDW	20208-SDWLG	18.50 x 18.37	470 x 467	16.25 x 15.00	413 x 381	1	10.00	254
20248-SD	20248-SDLG	-	-	18.50 x 22.37	470 x 568	-	-	1	10.00	254
24168-SD	24168-SDLG	-	-	22.50 x 14.37	572 x 365	-	-	1	5.00	127
24208-SD	24208-SDLG	24208-SDW	-	22.50 x 18.37	572 x 467	20.25 x 15.00	514 x 381	1	5.00	127
24248-SD	24248-SDLG	24248-SDW	24248-SDWLG	22.50 x 22.37	572 x 568	20.25 x 17.62	514 x 448	2	5.00	127
24308-SD	24308-SDLG	-	-	22.50 x 28.37	572 x 721	-	-	2	5.00	127
30208-SD	30208-SDLG	-	-	28.50 x 18.37	724 x 467	-	-	2	5.00	127
30248-SD	30248-SDLG	30248-SDW	30248-SDWLG	28.50 x 22.37	724 x 568	26.25 x 17.62	667 x 448	2	5.00	127
30308-SD	30308-SDLG	-	-	28.50 x 28.37	724 x 721	-	-	2	5.00	127
36248-SD	36248-SDLG	-	-	34.50 x 22.37	876 x 568	-	-	2	5.00	127
36308-SD	36308-SDLG	-	-	34.50 x 28.37	876 x 721	-	-	2	5.00	127
36368-SD	36368-SDLG	-	-	34.50 x 34.37	876 x 873	-	-	2	5.00	127
161210-SD	161210-SDLG	161210-SDW	-	14.50 x 10.37	368 x 264	12.25 x 7.00	311 x 178	1	8.00	203
161610-SD	161610-SDLG	-	-	14.50 x 14.37	368 x 365	-	-	1	8.00	203
162010-SD	162010-SDLG	-	-	14.50 x 18.37	368 x 467	-	-	1	8.00	203
201610-SD	201610-SDLG	201610-SDW	201610-SDWLG	18.50 x 14.37	470 x 365	16.25 x 11.00	413 x 279	1	10.00	254
202010-SD	202010-SDLG	202010-SDW	202010-SDWLG	18.50 x 18.37	470 x 467	16.25 x 15.00	413 x 381	1	10.00	254
202410-SD	202410-SDLG	-	-	18.50 x 22.37	470 x 568	-	-	1	10.00	254
241610-SD	241610-SDLG	-	-	22.50 x 14.37	572 x 365	-	-	1	5.00	127
242010-SD	242010-SDLG	242010-SDW	242010-SDWLG	22.50 x 18.37	572 x 467	20.25 x 15.00	514 x 381	1	5.00	127
242410-SD	242410-SDLG	242410-SDW	242410-SDWLG	22.50 x 22.37	572 x 568	20.25 x 17.62	514 x 448	2	5.00	127
243010-SD	243010-SDLG	-	-	22.50 x 28.37	572 x 721	-	-	2	5.00	127
302010-SD	302010-SDLG	-	-	28.50 x 18.37	724 x 467	-	-	2	5.00	127
302410-SD	302410-SDLG	302410-SDW	302410-SDWLG	28.50 x 22.37	724 x 568	26.25 x 17.62	667 x 448	2	5.00	127
303010-SD	303010-SDLG	-	-	28.50 x 28.37	724 x 721	-	-	2	5.00	127
362410-SD	362410-SDLG	-	-	34.50 x 22.37	876 x 568	-	-	2	5.00	127
363010-SD	363010-SDLG	-	-	34.50 x 28.37	876 x 721	-	-	2	5.00	127
423010-SD	-	-	-	40.50 x 28.37	1029 x 721	-	-	3	5.00	127
363610-SD	363610-SDLG	-	-	34.50 x 34.37	876 x 873	-	-	2	5.00	127
423610-SD	423610-SDLG	-	-	40.50 x 34.37	1029 x 873	-	-	3	5.00	127
482410-SD	482410-SDLG	-	-	46.50 x 22.37	1181 x 568	-	-	3	5.00	127
483010-SD	-	-	-	46.50 x 28.37	1181 x 721	-	-	3	5.00	127
483610-SD	483610-SDLG	-	-	46.50 x 34.37	1181 x 873	-	-	3	5.00	127
603610-SD	603610-SDLG	-	-	58.50 x 34.37	1486 x 873	-	-	3	5.00	127
202012-SD	202012-SDLG	202012-SDW	202012-SDWLG	18.50 x 18.37	470 x 467	16.25 x 15.00	413 x 381	1	10.00	254
242012-SD	242012-SDLG	242012-SDW	242012-SDWLG	22.50 x 18.37	572 x 467	20.25 x 15.00	514 x 381	1	5.00	127
242412-SD	242412-SDLG	242412-SDW	242412-SDWLG	22.50 x 22.37	572 x 568	20.25 x 17.62	514 x 448	2	5.00	127

Notes: Dimensions are in inches. Millimeters shown are for reference only. Data subject to change without notice.

Type 4 Panel Enclosures

Type 4 Panel Enclosures

Wall-Mount Enclosures Type 4 Premier™ Series with Quarter-Turn Latches Catalog Number

Enclosure Catalog Number				Enclosure Size		Door/Body Gauge	Panel Catalog Number	Panel Size	
Solid Door		Window Door		A x B x C				H x W	
ANSI 61 Gray	RAL7035 Lt. Gray	ANSI 61 Gray	RAL7035 Lt. Gray	in.	mm			in.	mm
302412-SD	302412-SDLG	302412-SDW	302412-SDWLG	30 x 24 x 12	762 x 610 x 305	14/16	3024P	28.00 x 22.00	711 x 559
303012-SD	303012-SDLG	-	-	30 x 30 x 12	762 x 762 x 305	14/14	3030P	28.00 x 28.00	711 x 711
362412-SD	362412-SDLG	-	-	36 x 24 x 12	914 x 610 x 305	14/14	3624P	34.00 x 22.00	864 x 559
363012-SD	363012-SDLG	-	-	36 x 30 x 12	914 x 762 x 305	14/14	3630P	34.00 x 28.00	864 x 711
423012-SD	423012-SDLG	-	-	42 x 30 x 12	1067 x 762 x 305	14/14	4230P	40.00 x 28.00	1016 x 711
363612-SD	363612-SDLG	-	-	36 x 36 x 12	914 x 914 x 305	14/14	3636P	34.00 x 34.00	864 x 864
423612-SD	423612-SDLG	-	-	42 x 36 x 12	1067 x 914 x 305	14/14	4236P	40.00 x 34.00	1016 x 864
482412-SD	482412-SDLG	-	-	48 x 24 x 12	1219 x 610 x 305	14/14	4824P	46.00 x 22.00	1168 x 559
483612-SD	483612-SDLG	-	-	48 x 36 x 12	1219 x 914 x 305	14/14	4836P	46.00 x 34.00	1168 x 864
603612-SD	603612-SDLG	-	-	60 x 36 x 12	1524 x 914 x 305	14/14	6036P	58.00 x 34.00	1473 x 864
242016-SD	-	-	-	24 x 20 x 16	610 x 508 x 406	14/14	2420P	22.00 x 18.00	559 x 457
242416-SD	242416-SDLG	242416-SDW	242416-SDWLG	24 x 24 x 16	610 x 610 x 406	14/14	2424P	22.00 x 22.00	559 x 559
302416-SD	-	-	-	30 x 24 x 16	762 x 610 x 406	14/14	3024P	28.00 x 22.00	711 x 559
362416-SD	-	-	-	36 x 24 x 16	914 x 610 x 406	14/14	3624P	34.00 x 22.00	864 x 559
363016-SD	363016-SDLG	-	-	36 x 30 x 16	914 x 762 x 406	14/14	3630P	34.00 x 28.00	864 x 711
423616-SD	-	-	-	42 x 36 x 16	1067 x 914 x 406	14/14	4236P	40.00 x 34.00	1016 x 864
483616-SD	483616-SDLG	-	-	48 x 36 x 16	1219 x 914 x 406	14/14	4836P	46.00 x 34.00	1168 x 864
603616-SD	-	-	-	60 x 36 x 16	1524 x 914 x 406	14/14	6036P	58.00 x 34.00	1473 x 864
242420-SD	242420-SDLG	242420-SDW	242420-SDWLG	24 x 24 x 20	610 x 610 x 508	14/14	2424P	22.00 x 22.00	559 x 559
302420-SD	302420-SDLG	302420-SDW	302420-SDWLG	30 x 24 x 20	762 x 610 x 508	14/14	3024P	28.00 x 22.00	711 x 559
363020-SD	363020-SDLG	-	-	36 x 30 x 20	914 x 762 x 508	14/14	3630P	34.00 x 28.00	864 x 711
483620-SD	-	-	-	48 x 36 x 20	1219 x 914 x 508	14/14	4836P	46.00 x 34.00	1168 x 864
603620-SD	-	-	-	60 x 36 x 20	1524 x 914 x 508	14/14	6036P	58.00 x 34.00	1473 x 864

Type 4 Panel Enclosures

Illustration Without Window

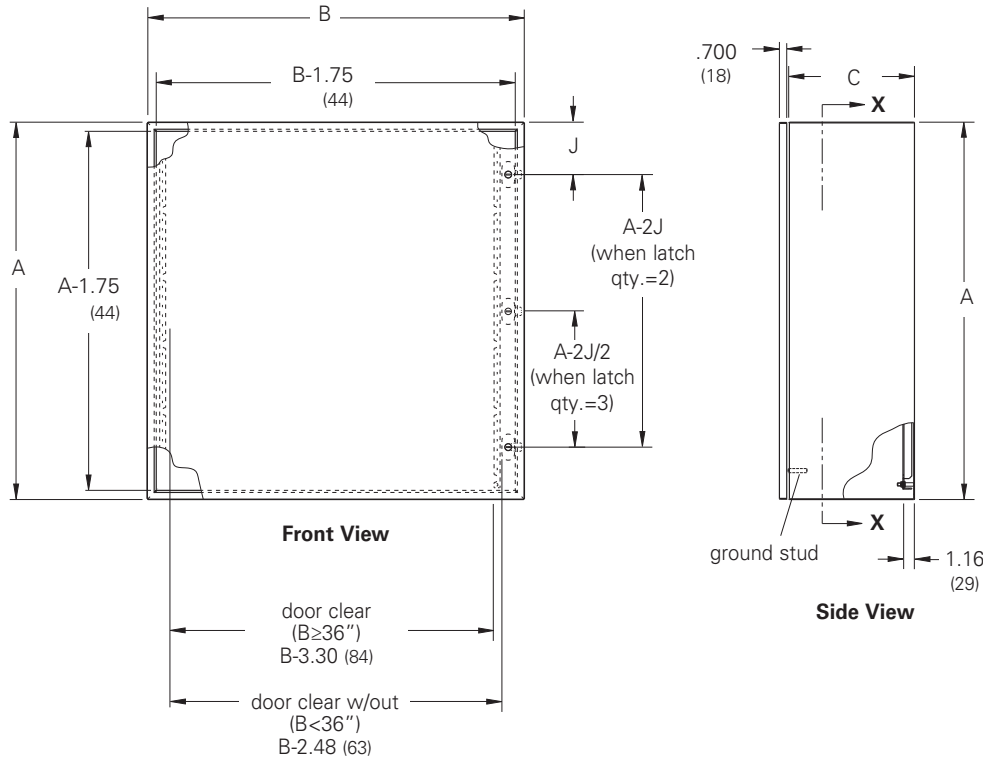

Notes: Dimensions are in inches. Millimeters shown are for reference only. Data subject to change without notice.

Wall-Mount Enclosures Type 4 Premier™ Series with Quarter-Turn Latches

Catalog Number cont. from page 148

Enclosure Catalog Number				Mounting		Window Size		Latch Quantity	J	
Solid Door		Window Door		D x E		F x G			in.	mm
ANSI 61 Gray	RAL7035 Lt. Gray	ANSI 61 Gray	RAL7035 Lt. Gray	in.	mm	in.	mm			
302412-SD	302412-SDLG	302412-SDW	302412-SDWLG	28.50 x 22.37	724 x 568	26.25 x 17.62	667 x 448	2	5.00	127
303012-SD	303012-SDLG	-	-	28.50 x 28.37	724 x 721	-	-	2	5.00	127
362412-SD	362412-SDLG	-	-	34.50 x 22.37	876 x 568	-	-	2	5.00	127
363012-SD	363012-SDLG	-	-	34.50 x 28.37	876 x 721	-	-	2	5.00	127
423012-SD	423012-SDLG	-	-	40.50 x 28.37	1029 x 721	-	-	3	5.00	127
363612-SD	363612-SDLG	-	-	34.50 x 34.37	876 x 873	-	-	2	5.00	127
423612-SD	423612-SDLG	-	-	40.50 x 34.37	1029 x 873	-	-	3	5.00	127
482412-SD	482412-SDLG	-	-	46.50 x 22.37	1181 x 568	-	-	3	5.00	127
483612-SD	483612-SDLG	-	-	46.50 x 34.37	1181 x 873	-	-	3	5.00	127
603612-SD	603612-SDLG	-	-	58.50 x 34.37	1486 x 873	-	-	3	5.00	127
242016-SD	-	-	-	22.50 x 18.37	572 x 467	-	-	2	5.00	127
242416-SD	242416-SDLG	242416-SDW	242416-SDWLG	22.50 x 22.37	572 x 568	20.25 x 17.62	514 x 448	2	5.00	127
302416-SD	-	-	-	28.50 x 22.37	725 x 568	-	-	2	5.00	127
362416-SD	-	-	-	34.50 x 22.37	876 x 568	-	-	2	5.00	127
363016-SD	363016-SDLG	-	-	34.50 x 28.37	876 x 721	-	-	2	5.00	127
423616-SD	-	-	-	40.50 x 34.37	1029 x 873	-	-	3	5.00	127
483616-SD	483616-SDLG	-	-	46.50 x 34.37	1181 x 873	-	-	3	5.00	127
603616-SD	-	-	-	58.50 x 34.37	1486 x 873	-	-	3	5.00	127
242420-SD	242420-SDLG	242420-SDW	242420-SDWLG	22.50 x 22.37	572 x 568	20.25 x 17.62	514 x 448	2	5.00	127
302420-SD	302420-SDLG	302420-SDW	302420-SDWLG	28.50 x 22.37	724 x 568	26.25 x 17.62	667 x 448	2	5.00	127
363020-SD	363020-SDLG	-	-	34.50 x 28.37	876 x 721	-	-	2	5.00	127
483620-SD	-	-	-	46.50 x 34.37	1181 x 873	-	-	3	5.00	127
603620-SD	-	-	-	58.50 x 34.37	1486 x 873	-	-	3	5.00	127

Illustration With Window

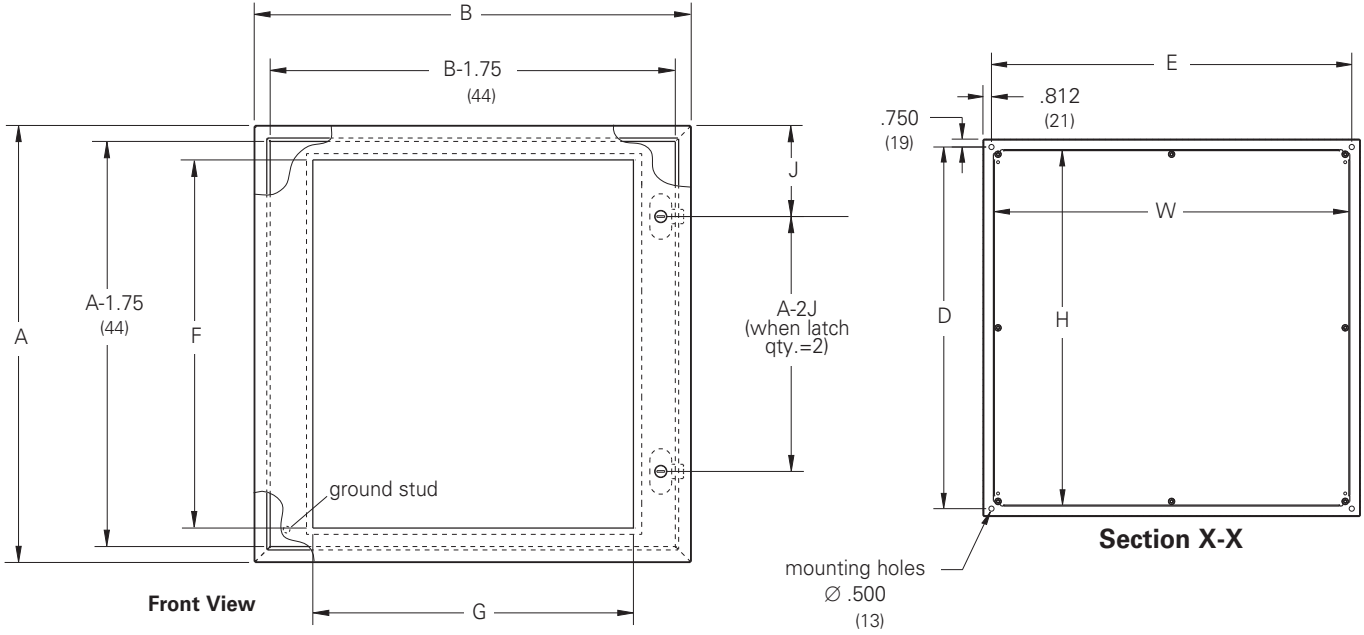

Notes: Dimensions are in inches. Millimeters shown are for reference only. Data subject to change without notice.