

Type 12 / 13 Panel Enclosures

JIC Enclosures Type 12 Continuous Hinge Cover Data Sheet



Type 12/13 Panel Encl.

Application

- Houses electrical controls and instruments
- Protects against circulating dust, falling dirt and dripping non-corrosive liquids

Standards

- UL 508 listed, Type 12 and Type 13
- CSA C22.2 No.94 certified, Type 12 and Type 13
- Conforms to NEMA standard for Type 12 and Type 13

Finish

- Wash and phosphate undercoat
- ANSI 61 gray polyester powder finish
- Hardware and clamps are zinc plated

Accessories

- Panels
- JIC terminal strap kit
- JIC terminal strip kit
- Terminal blocks
- Touch-up paint
- #8-32 self tapping screw (10168)
- See Accessories section

Construction

- Enclosure and cover are fabricated from (16) gauge steel
- All continuous welded seams are finished smooth
- Cover is secured to the body with a continuous hinge on one side and easy-to-operate screw clamps mounted to the opposite side
- Cover has a seamless poured in-place gasket
- Ground stud provided on cover
- #10-32 weldnuts are provided for mounting optional panel on 6" x 4" and larger enclosures
- External mounting feet are provided for secure wall mounting

Discount Schedule: C2

Subclass: DE0

Notes: We can provide special sizes, finishes and other modifications. Consult the factory for your special requirements.

JIC Enclosures Type 12 Continuous Hinge Cover Illustration Sheet and Catalog Number

Enclosure Catalog Number	Enclosure Size Height x Width x Depth A x B x C		D		Panel Catalog Number		Panel Size Height x Width	
	in.	mm	in.	mm	Solid	Perforated	in.	mm
443-12CHC	4.00 x 4.00 x 3.00	102 x 102 x 76	2.00	51	--	--	--	--
643-12CHC	6.00 x 4.00 x 3.00	152 x 102 x 76	3.00	76	AW64P	AW64PP	4.87 x 2.87	124 x 73
863.5-12CHC	8.00 x 6.00 x 3.50	203 x 152 x 89	4.00	102	AW86P	AW86PP	6.87 x 4.87	174 x 124
444-12CHC	4.00 x 4.00 x 4.00	102 x 102 x 102	2.00	51	--	--	--	--
644-12CHC	6.00 x 4.00 x 4.00	152 x 102 x 102	3.00	76	AW64P	AW64PP	4.87 x 2.87	124 x 76
664-12CHC	6.00 x 6.00 x 4.00	152 x 152 x 102	3.00	76	AW66P	AW66PP	4.87 x 4.87	124 x 124
884-12CHC	8.00 x 8.00 x 4.00	203 x 203 x 102	4.00	102	AW88P	AW88PP	6.87 x 6.87	174 x 174
1084-12CHC	10.00 x 8.00 x 4.00	254 x 203 x 102	2.00	51	AW108P	AW108PP	8.87 x 6.87	225 x 174
1084-12CHCS	10.00 x 8.00 x 4.00	254 x 203 x 102	2.00	51	AW108P	AW108PP	8.87 x 6.87	225 x 174
1264-12CHC	12.00 x 6.00 x 4.00	305 x 152 x 102	3.00	76	AW126P	AW126PP	10.87 x 4.87	272 x 124
12105-12CHC	12.00 x 10.00 x 5.00	305 x 254 x 127	3.00	76	AW1210P	AW1210PP	10.87 x 8.87	272 x 225
12105-12CHCS	12.00 x 10.00 x 5.00	305 x 254 x 127	3.00	76	AW1210P	AW1210PP	10.87 x 8.87	272 x 225
866-12CHC	8.00 x 6.00 x 6.00	203 x 152 x 152	4.00	102	AW86P	AW86PP	6.87 x 4.87	174 x 124
886-12CHC	8.00 x 8.00 x 6.00	203 x 203 x 152	4.00	102	AW88P	AW88PP	6.87 x 6.87	174 x 174
1086-12CHC	10.00 x 8.00 x 6.00	254 x 203 x 152	2.00	51	AW108P	AW108PP	8.87 x 6.87	225 x 174
10106-12CHC	10.00 x 10.00 x 6.00	254 x 254 x 152	2.00	51	AW1010P	AW1010PP	8.87 x 8.87	225 x 225
12106-12CHC	12.00 x 10.00 x 6.00	305 x 254 x 152	3.00	76	AW1210P	AW1210PP	10.87 x 8.87	272 x 225
12126-12CHC	12.00 x 12.00 x 6.00	305 x 305 x 152	3.00	76	AW1212P	AW1212PP	10.87 x 10.87	272 x 272
1486-12CHC	14.00 x 8.00 x 6.00	356 x 203 x 152	3.00	76	AW148P	AW148PP	12.87 x 6.87	327 x 174
14126-12CHC	14.00 x 12.00 x 6.00	356 x 305 x 152	3.00	76	AW1412P	AW1412PP	12.87 x 10.87	327 x 272
14126-12CHCS	14.00 x 12.00 x 6.00	356 x 305 x 152	3.00	76	AW1412P	AW1412PP	12.87 x 10.87	327 x 272
16106-12CHC	16.00 x 10.00 x 6.00	406 x 254 x 152	3.00	76	AW1610P	AW1610PP	14.87 x 8.87	378 x 225
16146-12CHC	16.00 x 14.00 x 6.00	406 x 356 x 152	3.00	76	AW1614P	AW1614PP	14.87 x 12.87	378 x 327
16146-12CHCS	16.00 x 14.00 x 6.00	406 x 356 x 152	3.00	76	AW1614P	AW1614PP	14.87 x 12.87	378 x 327
10108-12CHC	10.00 x 10.00 x 8.00	254 x 254 x 203	2.00	51	AW1010P	AW1010PP	8.87 x 8.87	225 x 225
12108-12CHC	12.00 x 10.00 x 8.00	305 x 254 x 203	3.00	76	AW1210P	AW1210PP	10.87 x 8.87	272 x 225
14128-12CHC	14.00 x 12.00 x 8.00	356 x 305 x 203	3.00	76	AW1412P	AW1412PP	12.87 x 10.87	327 x 272
16148-12CHC	16.00 x 14.00 x 8.00	406 x 356 x 203	3.00	76	AW1614P	AW1614PP	14.87 x 12.87	378 x 327
161410-12CHC	16.00 x 14.00 x 10.00	406 x 356 x 254	3.00	76	AW1614P	AW1614PP	14.87 x 12.87	378 x 327

Note: Catalog numbers ending in -12 CHCS are hinged on the short side.

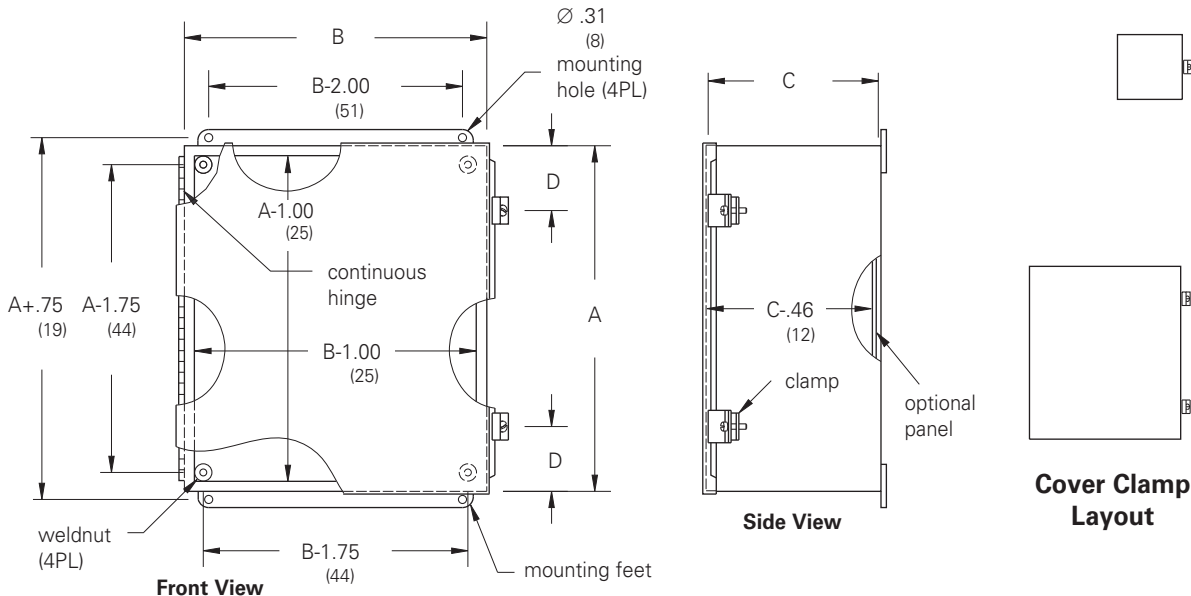

Notes: Dimensions are in inches. Millimeters shown are for reference only. Data subject to change without notice.

Type 12 / 13 Panel Enclosures

JIC Enclosures Type 12 Continuous Hinge Cover Data Sheet



Type 12/13 Panel Encl.

Application

- Houses electrical controls and instruments
- Protects against circulating dust, falling dirt and dripping non-corrosive liquids

Standards

- UL 508 listed, Type 12 and Type 13
- CSA C22.2 No.94 certified, Type 12 and Type 13
- Conforms to NEMA standard for Type 12 and Type 13

Finish

- Wash and phosphate undercoat
- ANSI 61 gray polyester powder finish
- Hardware and clamps are zinc plated

Accessories

- Panels
- JIC terminal strap kit
- JIC terminal strip kit
- Terminal blocks
- Touch-up paint
- #8-32 self tapping screw (10168)
- See Accessories section

Construction

- Enclosure and cover are fabricated from (16) gauge steel
- All continuous welded seams are finished smooth
- Cover is secured to the body with a continuous hinge on one side and easy-to-operate screw clamps mounted to the opposite side
- Cover has a seamless poured in-place gasket
- Ground stud provided on cover
- #10-32 weldnuts are provided for mounting optional panel on 6" x 4" and larger enclosures
- External mounting feet are provided for secure wall mounting

Discount Schedule: C2

Subclass: DE0

Notes: We can provide special sizes, finishes and other modifications. Consult the factory for your special requirements.

JIC Enclosures Type 12 Continuous Hinge Cover Illustration Sheet and Catalog Number

Enclosure Catalog Number	Enclosure Size Height x Width x Depth A x B x C		D		Panel Catalog Number		Panel Size Height x Width	
	in.	mm	in.	mm	Solid	Perforated	in.	mm
443-12CHC	4.00 x 4.00 x 3.00	102 x 102 x 76	2.00	51	--	--	--	--
643-12CHC	6.00 x 4.00 x 3.00	152 x 102 x 76	3.00	76	AW64P	AW64PP	4.87 x 2.87	124 x 73
863.5-12CHC	8.00 x 6.00 x 3.50	203 x 152 x 89	4.00	102	AW86P	AW86PP	6.87 x 4.87	174 x 124
444-12CHC	4.00 x 4.00 x 4.00	102 x 102 x 102	2.00	51	--	--	--	--
644-12CHC	6.00 x 4.00 x 4.00	152 x 102 x 102	3.00	76	AW64P	AW64PP	4.87 x 2.87	124 x 76
664-12CHC	6.00 x 6.00 x 4.00	152 x 152 x 102	3.00	76	AW66P	AW66PP	4.87 x 4.87	124 x 124
884-12CHC	8.00 x 8.00 x 4.00	203 x 203 x 102	4.00	102	AW88P	AW88PP	6.87 x 6.87	174 x 174
1084-12CHC	10.00 x 8.00 x 4.00	254 x 203 x 102	2.00	51	AW108P	AW108PP	8.87 x 6.87	225 x 174
1084-12CHCS	10.00 x 8.00 x 4.00	254 x 203 x 102	2.00	51	AW108P	AW108PP	8.87 x 6.87	225 x 174
1264-12CHC	12.00 x 6.00 x 4.00	305 x 152 x 102	3.00	76	AW126P	AW126PP	10.87 x 4.87	272 x 124
12105-12CHC	12.00 x 10.00 x 5.00	305 x 254 x 127	3.00	76	AW1210P	AW1210PP	10.87 x 8.87	272 x 225
12105-12CHCS	12.00 x 10.00 x 5.00	305 x 254 x 127	3.00	76	AW1210P	AW1210PP	10.87 x 8.87	272 x 225
866-12CHC	8.00 x 6.00 x 6.00	203 x 152 x 152	4.00	102	AW86P	AW86PP	6.87 x 4.87	174 x 124
886-12CHC	8.00 x 8.00 x 6.00	203 x 203 x 152	4.00	102	AW88P	AW88PP	6.87 x 6.87	174 x 174
1086-12CHC	10.00 x 8.00 x 6.00	254 x 203 x 152	2.00	51	AW108P	AW108PP	8.87 x 6.87	225 x 174
10106-12CHC	10.00 x 10.00 x 6.00	254 x 254 x 152	2.00	51	AW1010P	AW1010PP	8.87 x 8.87	225 x 225
12106-12CHC	12.00 x 10.00 x 6.00	305 x 254 x 152	3.00	76	AW1210P	AW1210PP	10.87 x 8.87	272 x 225
12126-12CHC	12.00 x 12.00 x 6.00	305 x 305 x 152	3.00	76	AW1212P	AW1212PP	10.87 x 10.87	272 x 272
1486-12CHC	14.00 x 8.00 x 6.00	356 x 203 x 152	3.00	76	AW148P	AW148PP	12.87 x 6.87	327 x 174
14126-12CHC	14.00 x 12.00 x 6.00	356 x 305 x 152	3.00	76	AW1412P	AW1412PP	12.87 x 10.87	327 x 272
14126-12CHCS	14.00 x 12.00 x 6.00	356 x 305 x 152	3.00	76	AW1412P	AW1412PP	12.87 x 10.87	327 x 272
16106-12CHC	16.00 x 10.00 x 6.00	406 x 254 x 152	3.00	76	AW1610P	AW1610PP	14.87 x 8.87	378 x 225
16146-12CHC	16.00 x 14.00 x 6.00	406 x 356 x 152	3.00	76	AW1614P	AW1614PP	14.87 x 12.87	378 x 327
16146-12CHCS	16.00 x 14.00 x 6.00	406 x 356 x 152	3.00	76	AW1614P	AW1614PP	14.87 x 12.87	378 x 327
10108-12CHC	10.00 x 10.00 x 8.00	254 x 254 x 203	2.00	51	AW1010P	AW1010PP	8.87 x 8.87	225 x 225
12108-12CHC	12.00 x 10.00 x 8.00	305 x 254 x 203	3.00	76	AW1210P	AW1210PP	10.87 x 8.87	272 x 225
14128-12CHC	14.00 x 12.00 x 8.00	356 x 305 x 203	3.00	76	AW1412P	AW1412PP	12.87 x 10.87	327 x 272
16148-12CHC	16.00 x 14.00 x 8.00	406 x 356 x 203	3.00	76	AW1614P	AW1614PP	14.87 x 12.87	378 x 327
161410-12CHC	16.00 x 14.00 x 10.00	406 x 356 x 254	3.00	76	AW1614P	AW1614PP	14.87 x 12.87	378 x 327

Note: Catalog numbers ending in -12 CHCS are hinged on the short side.

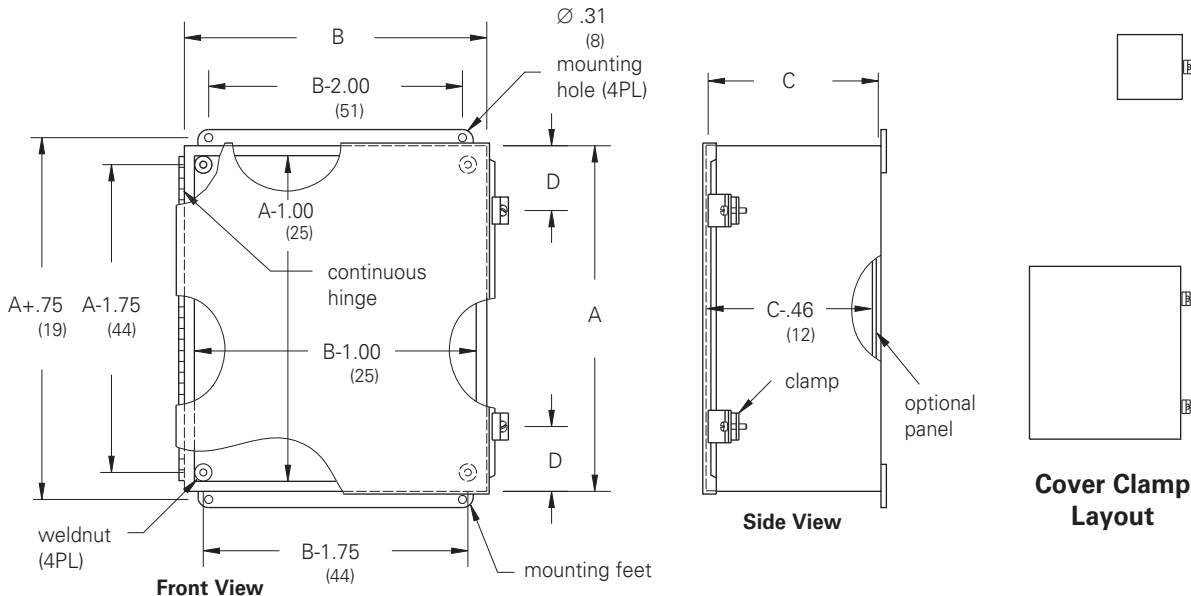

443-12CHC
643-12CHC
444-12CHC
644-12CHC
664-12CHC
863.5-12CHC
884-12CHC
866-12CHC
886-12CHC

1084-12CHC
1264-12CHC
12105-12CHC
1086-12CHC
10106-12CHC
12126-12CHC
1486-12CHC
14126-12CHC
16106-12CHC
10108-12CHC
16146-12CHC
12108-12CHC
14128-12CHC
16148-12CHC
161410-12CHC

Notes: Dimensions are in inches. Millimeters shown are for reference only. Data subject to change without notice.