

4

3

2

1

REVISIONS					
REV.	EC. NO.	DATE	DESCRIPTION	CREATED BY	CHECKED BY
B		2/18/2025	RELEASE	JR	
C		4/11/2025	CC MARKING	JR	
D		2/5/2026	PATENTS PENDING	JR	

1/2" STANDARD KNOCKOUT

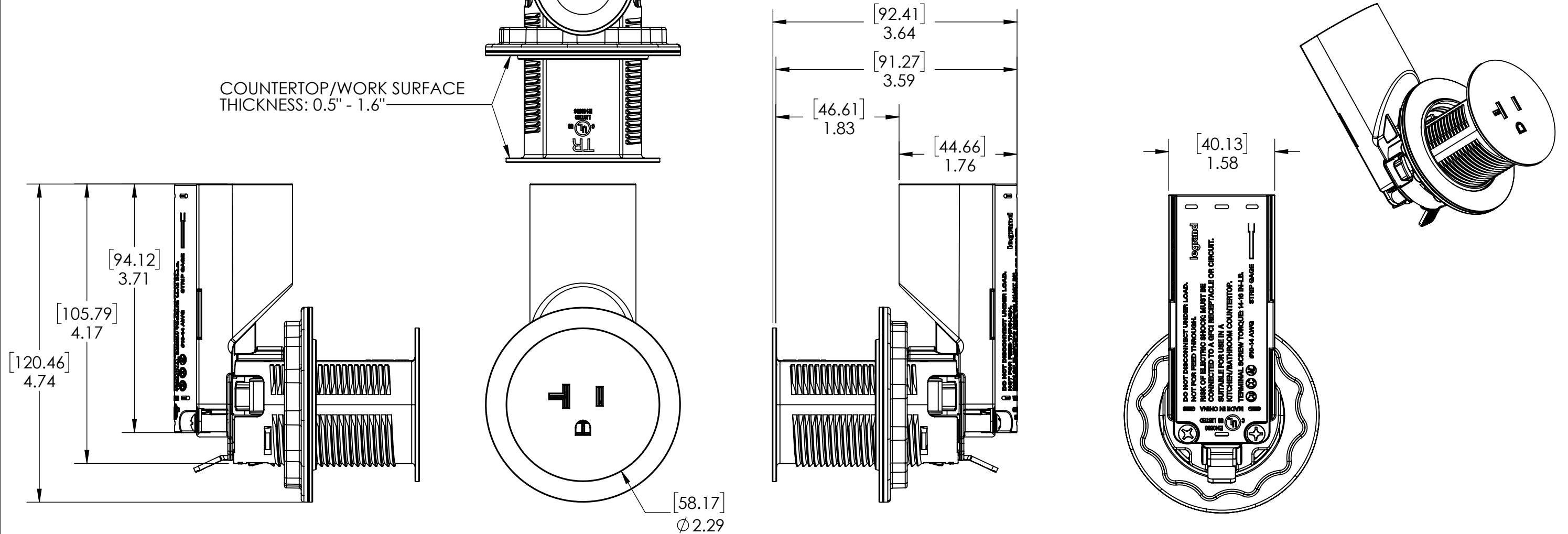
COUNTERTOP/WORK SURFACE
THICKNESS: 0.5" - 1.6"

NOTES:

- BASE CATALOG NUMBER: CP498TR20
- ELECTRICAL RATINGS:
 - 125V 20A
- 3RD PARTY:
 - CULUS LISTED: FILE NUMBER E140596, STANDARD 498 & 514C
 - CSA: 22.2 NO. 42
- TERMINATION: TAIL ONLY, PRESSURE WIRE
- MATERIAL:
 - FACE: GLASS FILLED NYLON
 - CONTACTS: NICKEL PLATED BRASS
 - TAMPER RESISTANT SHUTTERS: THERMOPLASTIC (DELTRIN)
- LEGRAND RESERVES THE RIGHT TO CHANGE SPECIFICATIONS WITHOUT NOTICE.
- PATENTS PENDING

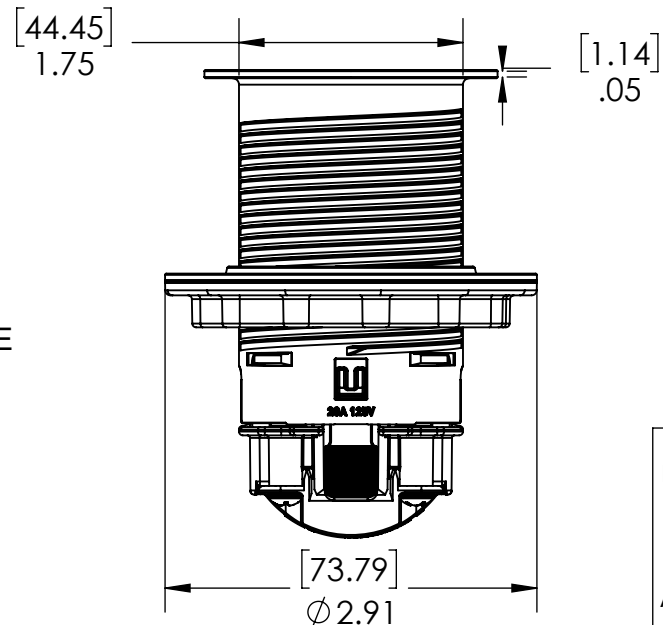

ENVIRONMENTAL MATERIAL REQUIREMENTS
 MATERIALS, PRODUCTS, PARTS AND ASSEMBLIES PROVIDED UNDER THIS DRAWING MUST MEET THE REQUIREMENTS DETAILED IN THE LATEST REVISION OF THE LEGRAND, NORTH & CENTRAL AMERICA CORPORATE ENVIRONMENTAL MATERIAL REQUIREMENTS (EMR) DOCUMENT EMS-009. ANY DEVIATION FROM THE EMR REQUIREMENTS MUST BE APPROVED BY AN AUTHORIZED REPRESENTATIVE OF LEGRAND PRODUCT ENGINEERING IN WRITING. THE LATEST EMR DOCUMENT IS AVAILABLE ON REQUEST.

Unspecified Tol. Frac $\pm 1/64$ Angles ± 1.0	Drawing Title CUSTOMER DRAWING CP498TR20	Scale: 1:2
	Model Number: CP498TR20	Sheet: 1 of 1
Created By: GW	Date: 1/21/2025	Rev. D
	P&S Drawing No.	

4

3

2

1