



## KT-DDSLEDT8-4-2L-X

### 4', 2-LAMP STRIP FIXTURE

#### DESCRIPTION

4' LED Tube ready strip fixture, 2 lamp. (lamps sold separately)  
White and Black Finishes available



RoHS Compliant

#### APPLICATION

Used for indoor highbay, lowbay, warehouse and general lighting applications.

#### PRODUCT FEATURES

- Designed for use with single ended wiring (type B) LED T8 tubes; includes pre-wired sockets
- Post painted white steel body
- Rated for dry and damp locations
- Designed only for use with Keystone single ended wiring DirectDrive LED lamps: 25W max per lamp



#### PRODUCT DIMENSIONS

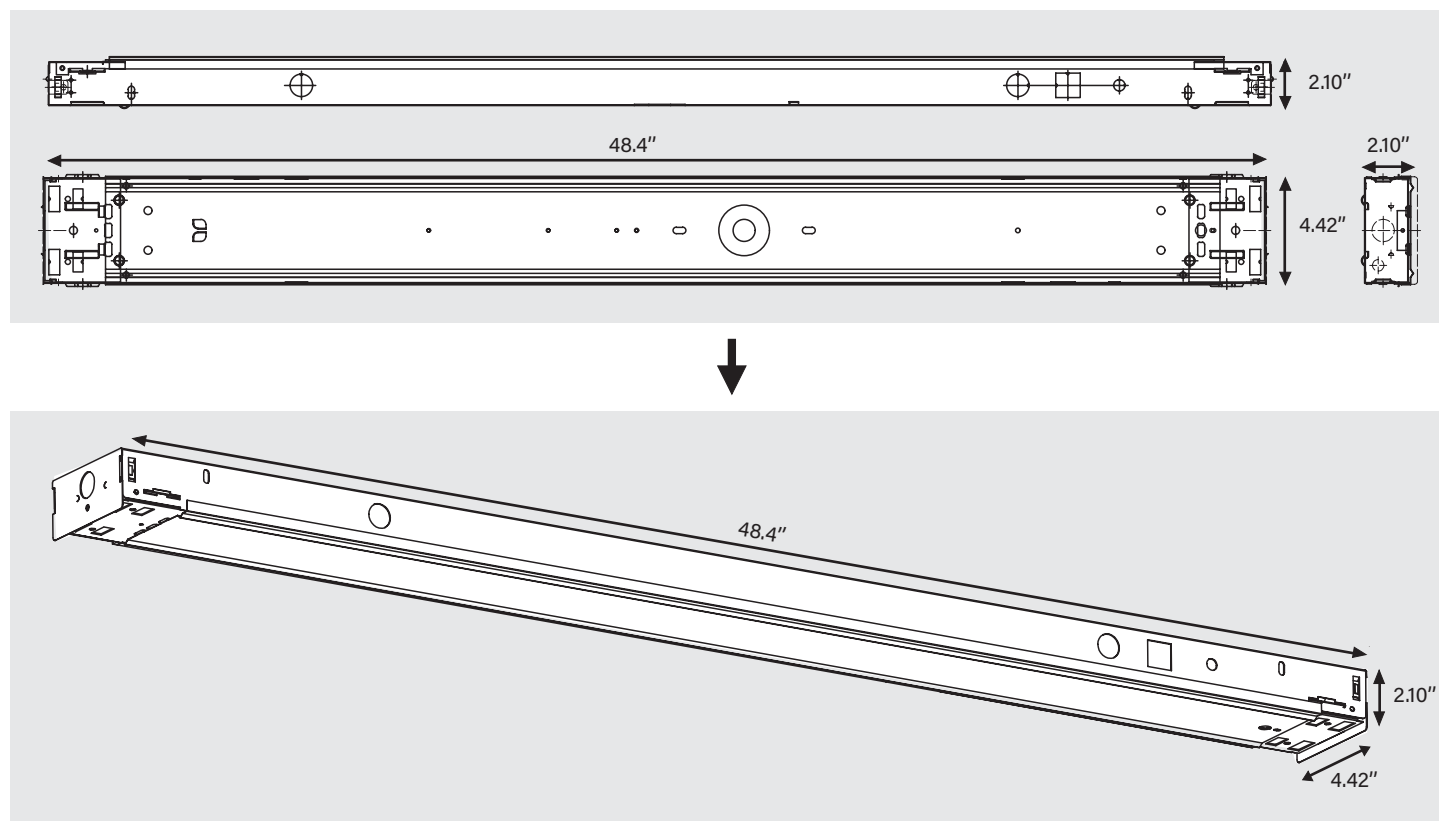

**Note:** In order for UL safety certification to be valid, only Keystone lamps may be installed in the fixture as per product label.



# KT-DDSLEDT8-4-2L-X

## 4', 2-LAMP STRIP FIXTURE

### ORDERING INFORMATION

ORDER CODE	PACK QTY.	EASY CODE	UPC
KT-DDSLEDT8-4-2L	1	JVQ-15	89094900381
KT-DDSLEDT8-4-2L-B	1	UNE-89	843654165998

### CATALOG NUMBER BREAKDOWN

# KT-DDSLEDT8-4-2L-X

1 2 3 4 5 6 7 8

- 1** Keystone Technologies
- 2** Direct Drive
- 3** Strip Fixture
- 4** LED Lamp
- 5** T8 Tubes
- 6** 4' Nominal Size
- 7** 2 Lamps
- 8** Housing Color

#### 8 Housing Color

	White
<b>B</b>	Black



## KT-DDSLEDT8-4-2L-X

### 4', 2-LAMP STRIP FIXTURE

#### DESCRIPTION

4' LED Tube ready strip fixture, 2 lamp. (lamps sold separately)  
White and Black Finishes available



RoHS Compliant

#### APPLICATION

Used for indoor highbay, lowbay, warehouse and general lighting applications.

#### PRODUCT FEATURES

- Designed for use with single ended wiring (type B) LED T8 tubes; includes pre-wired sockets
- Post painted white steel body
- Rated for dry and damp locations
- Designed only for use with Keystone single ended wiring DirectDrive LED lamps: 25W max per lamp



#### PRODUCT DIMENSIONS

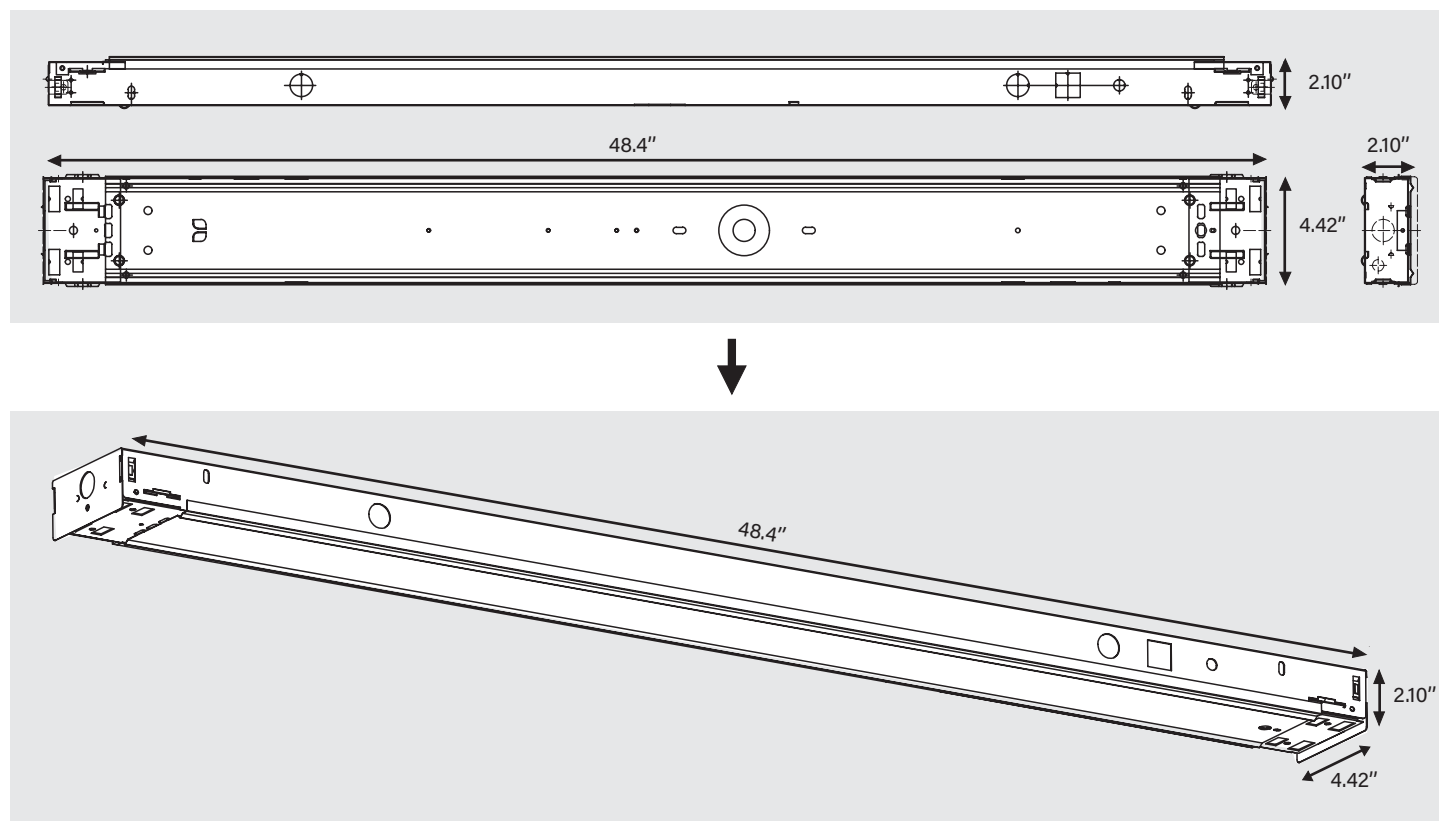

**Note:** In order for UL safety certification to be valid, only Keystone lamps may be installed in the fixture as per product label.



# KT-DDSLEDT8-4-2L-X

## 4', 2-LAMP STRIP FIXTURE

### ORDERING INFORMATION

ORDER CODE	PACK QTY.	EASY CODE	UPC
KT-DDSLEDT8-4-2L	1	JVQ-15	89094900381
KT-DDSLEDT8-4-2L-B	1	UNE-89	843654165998

### CATALOG NUMBER BREAKDOWN

# KT-DDSLEDT8-4-2L-X

1 2 3 4 5 6 7 8

- 1** Keystone Technologies
- 2** Direct Drive
- 3** Strip Fixture
- 4** LED Lamp
- 5** T8 Tubes
- 6** 4' Nominal Size
- 7** 2 Lamps
- 8** Housing Color

#### 8 Housing Color

	White
<b>B</b>	Black