

WIREMOLD®

Evolution™ Series Wall Boxes

Evolution™ Series Boxes...now available for walls

Evolution™ Series Wall Boxes are the latest advancement in the most innovative line of pathways in the industry. These wall boxes are designed for new work and old work applications while offering a sleek, clean look that architects will love and the functionality engineers and contractors require. Offered in a 2-gang version with a storage module for active A/V equipment and a 4-gang version when more power, communications, and A/V capacities are required, Evolution Series Wall Boxes are ideal for areas with large or small capacity needs. Evolution Series Wall Boxes are ideal for any area where a flat screen is required, such as: conference rooms, airports, entertainment venues, college campuses, and hospitals.

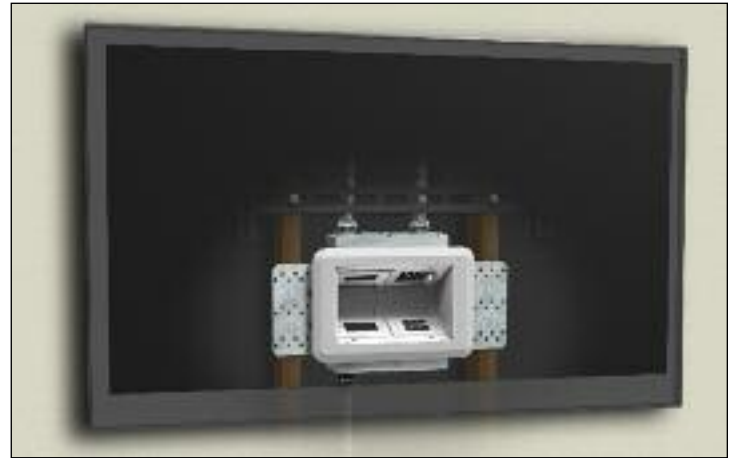

EFSB4 installed behind a flat screen display.

FEATURES & BENEFITS

■ **New work and old work applications.** Evolution Series Wall Boxes have been design to be able to be installed in both new work and old work installations. Saving time and money on the jobsite.

■ **Removable modules.** Removable modules facilitate quick and easy installations by allowing service feeds to be connected outside the box, increasing jobsite productivity and reducing overall project cost.



■ **Storage module.** The 2-gang Evolution Series Wall Box comes complete with a built-in storage module, large enough to hold the smaller receivers, and controllers that are typically found behind flat screen monitors.



■ **Available options.** Evolution Series Wall Boxes are available in both a 2-gang and a 4-gang version, allowing for maximum flexibility to fit the capacity needs of the task at hand.



■ **Finished cover.** Evolution Series Wall Boxes come complete with a decorative cover option that is field-paintable allowing the product to blend in and match the room decor.



■ **Low Profile Cover.** The decorative trim flange and cover are low profile (less than 1/4" from the wall surface) allowing the monitors to seat closer to wall.



FEATURES & BENEFITS (continued)

- **Built in Tunnel:** The built in tunnel allows services to be wrapped around, increasing flexibility and configurability, while reducing the number of service feeds that need to be brought to the box.

Tunnel

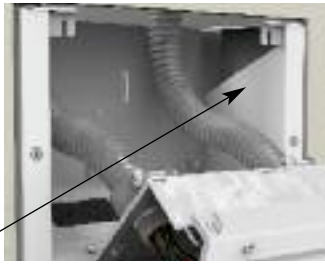

- **Feed Through Capability.** Between the removable modules and the tunneling feature, the Evolution Series Wall Boxes allows for service feeds to be fed through the boxes, reducing the number of feeds required, saving time and money.



- **Accepts standard size wall plates.** Each of the wall boxes are designed to accept standard size (2 3/4" x 4 1/2") [70mm x 114mm] device plates. No proprietary plates means quicker and easier installations.



- **Wiring Capacity:** 3 5/8" [92mm] of space behind the device plate allows for a maximum amount of space for wiring deeper A/V devices.

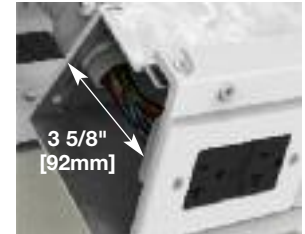

- **Finished interior.** Fully finished interior removes the unfinished industrial look while increasing visibility, making it easier to see where to plug in devices.



- **Plug-in Capacity.** 4 1/2" [114mm] of space between devices allows the end user to be able to easily plug into the active devices that are across from one another.

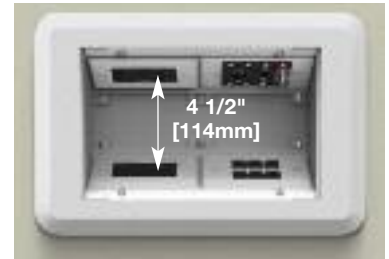

- **Multiple size knockouts.** All of the Evolution Series Wall boxes can accept service feeds from 3/4" trade size up to 2" trade size. These knockout plates are removable and interchangeable, providing the most flexibility and configurability options possible.



- **Datacom connectivity options.** Accepts industry standard and proprietary devices from a wide range of manufacturers to provide a seamless and aesthetically pleasing interface for voice, data and video applications at the point-of-use. A wide selection of data and adapter options are available for use with Ortronics® TracJack and Series II devices.

- **UL Listed to U.S. and Canadian safety standards.**

- **Removable Dividers.** Each module is supplied with one divider that can be removed and replaced when needed. Removable dividers allow for maximum configurability.

- **2" x 4" wall cavity.** The Evolution Series Wall Boxes are designed to fit within a standard 2"x 4" [51mm x 102mm] (metal or wood) wall cavity.

Evolution Series Floor Box Included Components

- KEY:**
 A. Main Body
 B. Mounting Bracket
 C. Tunnel
 D. Device Module
 E. Storage Module
 F. Trim Flange
 G. Decorative Cover

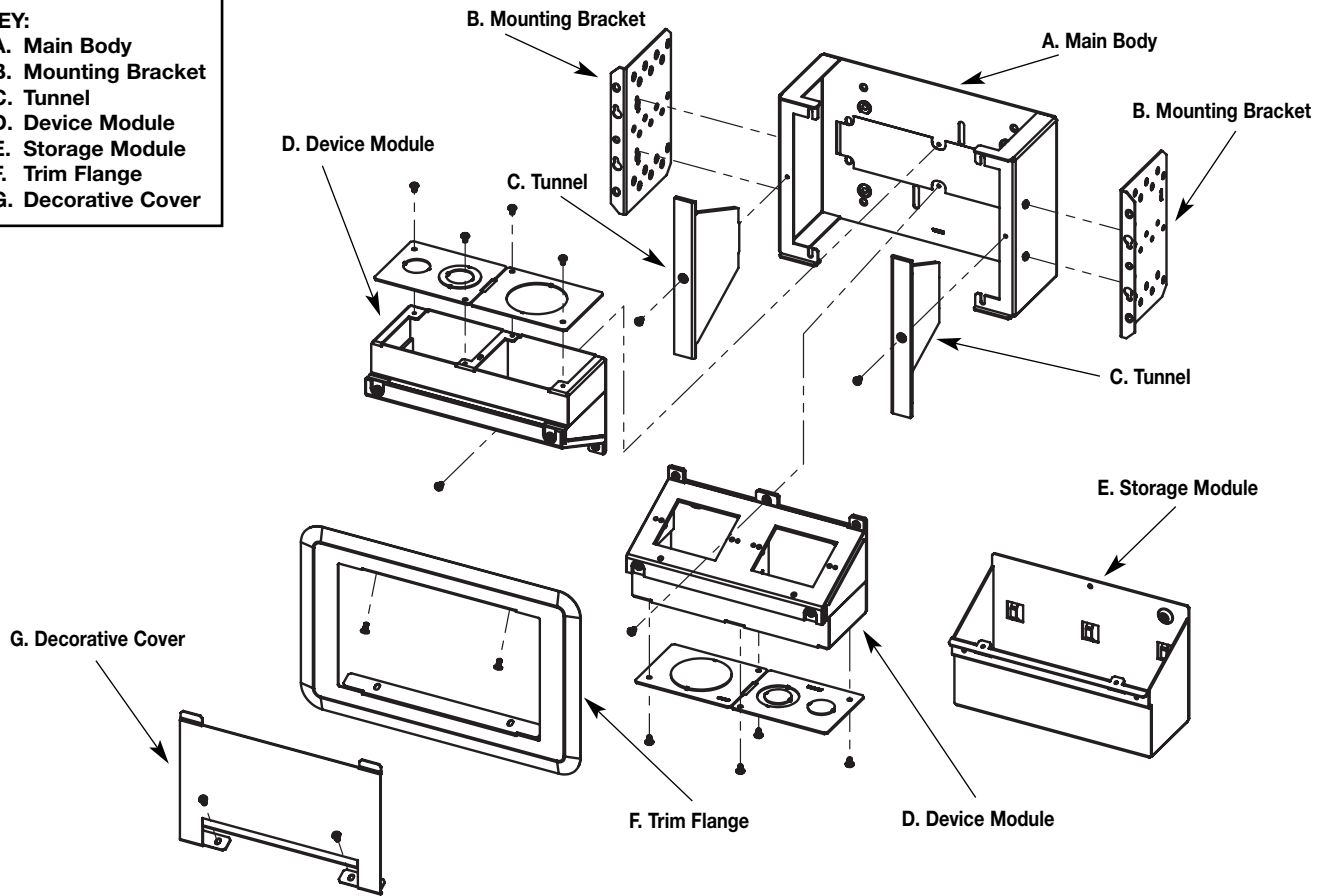

Evolution Series Wall Box Model Selection Guide

EVOLUTION WALL BOX MODEL	EFSB2	EFSB4
INSTALL TYPE: New Work Old Work	YES YES	
BOX CAPACITY:	2-Gangs	4-Gangs
DEPTH BEHIND PLATES:	3 5/8" [92mm]	
REMOVABLE MODULES:	YES	
DEVICE PLATE SIZE:	Uses Standard Size Device Plates: Single-Gang (2 3/4" x 4 1/2") [70mm x 114mm]	
COVER COLORS:	White	
COMPARTMENT VOLUMES:	43 cubic inches [705ml]	43 cubic inches [705ml]
KO SIZE RANGE: (Trade Size)	3/4" to 2"	
TUNNELS:	YES	
NOTES:	Trim flange and decorative cover are paintable	

Evolution Series EFSB2 Wall Box Ordering Information

Catalog No./Item

Description/Specifications

EFSB2

2-Gang Wall Box – Designed to fit and be concealed behind 42" [1.067m] or larger flat screen displays. Can be installed in both new work and old work applications. Has 2 NEMA size openings for power, communication, or A/V devices. Box is also equipped with a storage module that will accept active A/V equipment up to 6 7/8" x 9 1/8" [175mm x 232mm] (dimensions include wire and cables) in size.

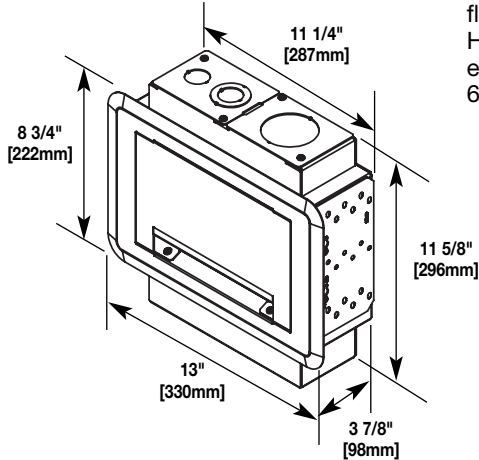

Components Included:

- A** Box Body
- B** Mounting Brackets (2)
- C** Tunnel (2)
- D** Device Module
- E** Storage Module
- F** Trim Flange
- G** Decorative Cover

Each Module Consists of:

- One (1) Device Bracket
- One (1) Back Box
- One (1) Removable Divider
- One (1) EFS-DIV Divider
- 3/4"-1 1/4" Removable KO Plate
- 2" Removable KO Plate

Items not included with the box and sold separately:

- Receptacles
- Communication Jacks
- A/V Devices
- Device plates

EFSB2 Exploded View

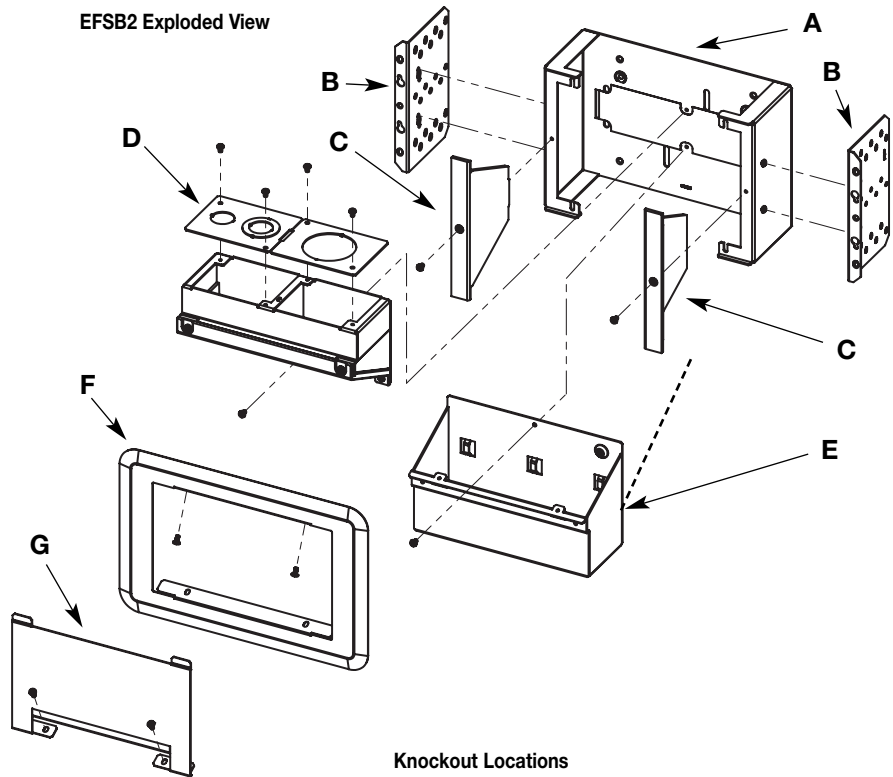

Device Module

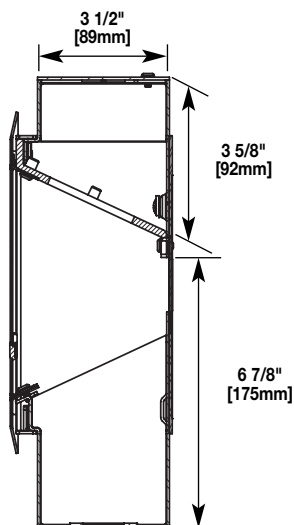

Knockout Locations

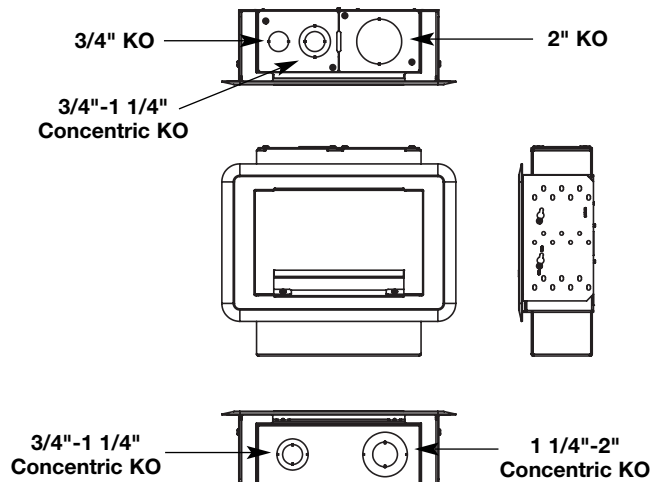

Evolution Series EFSB4 Wall Box Ordering Information

Catalog No./Item

Description/Specifications

EFSB4

4-Gang Wall Box – Designed to fit and be concealed behind 42" [1.067m] or larger flat screen displays. Can be installed in both new work and old work applications. Has 4 NEMA size openings for power, communication, or A/V devices.

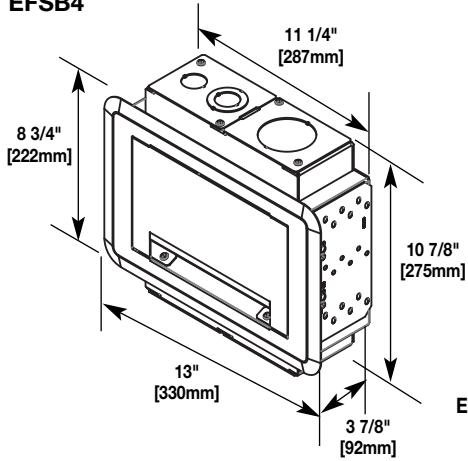

Components Included:

- A** Box Body
- B** Mounting Brackets (2)
- C** Tunnel (2)
- D** Device Modules (2)
- E** Trim Flange
- F** Decorative Cover

Each Module Consists of:

- One (1) Device Bracket
- One (1) Back Box
- One (1) Removable Divider
- One (1) EFS-DIV Divider
- 3/4"-1 1/4" Removable KO Plate
- 2" Removable KO Plate

Items not included with the box and sold separately:

- Receptacles
- Communication Jacks
- A/V Devices
- Device plates

EFSB4 Exploded View

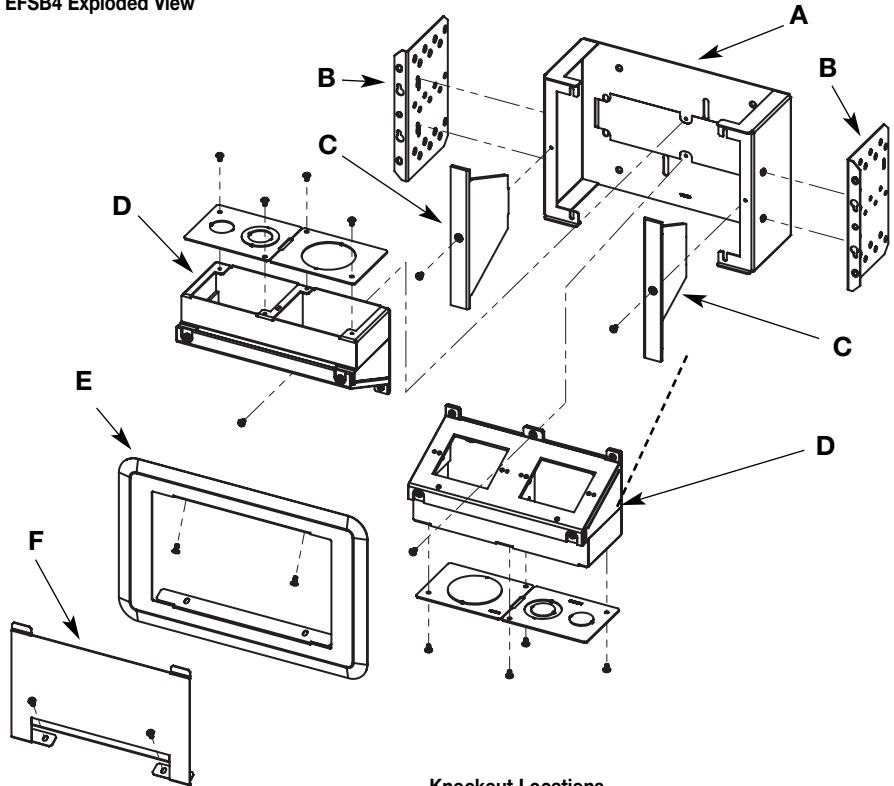



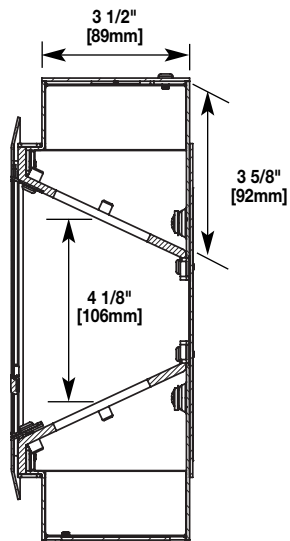

Device Module

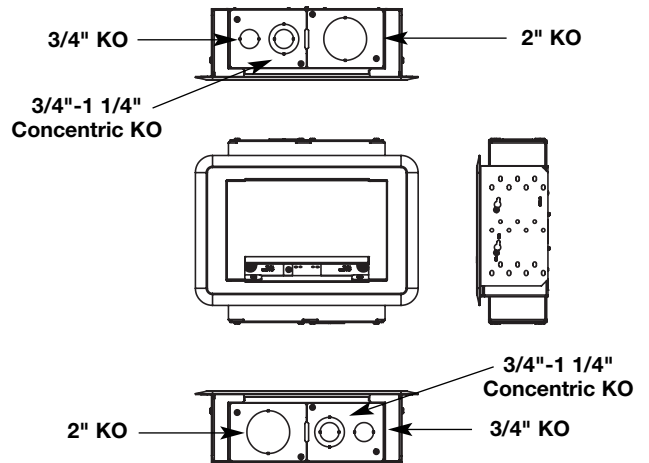

Knockout Locations

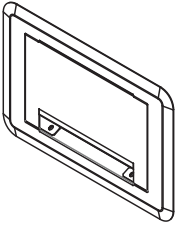
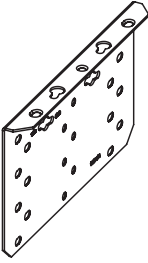
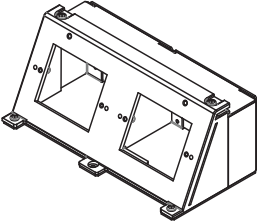

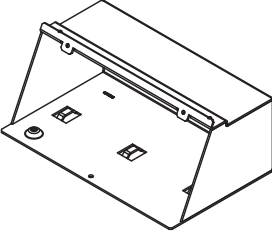
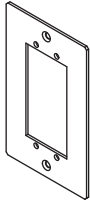
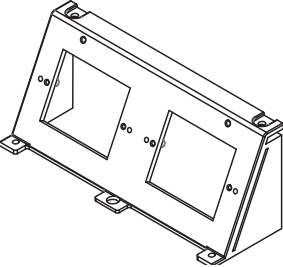
Evolution Series Wall Box Replacement Parts & Accessories Ordering Information

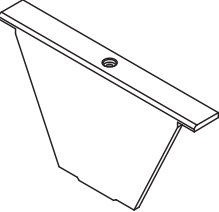
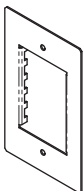
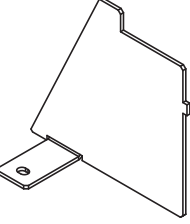
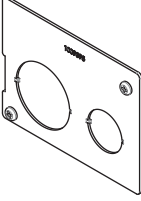
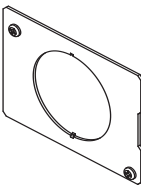
Catalog No./Item	Description/Specifications	Catalog No./Item	Description/Specifications
EFS-C 	Replacement Trim Flange & Cover Assembly – Replacement trim flange and decorative cover assembly for the EFSB2 and EFSB4 wall boxes. Trim flange and cover are finished in a decorative white color, with a paintable surface to match any room decor.	EFS-MB 	Replacement Mounting Bracket – Allows wall box to be secured to wall in both new work and old work applications. Includes 2 brackets.
EFS-DM 	Replacement Device Module – Comes complete with module base, 2" trade size knockout plate, 3/4" and 3/4" / 1-1/4" concentric knockout plate, and a removable divider. Finished in a decorative white color.	EFS-B 	Blank Device Plate – Device plate dimensions: 2 3/4" x 4 1/2" [69mm x 114mm].
EFS-SM 	Replacement Storage Module – Used to store active A/V equipment. Comes complete with tie-down locations to secure devices in place. Decorative white finish. Includes one (1) storage module.	EFS-AAP 	Device Plate – holds two (2) Extron® Electronics AAP devices. Device plate dimensions: 2 3/4" x 4 1/2" [69mm x 114mm].
EFS-DB 	Replacement 2-Gang Device Bracket – Each location is sized to accept NEMA standard devices. Device bracket will fit both the EFSB2 and EFSB4 wall boxes. Includes one (1) bracket.	EFS-MAAP 	Device Plate – holds four (4) Extron® Electronics MAAP devices. Device plate dimensions: 2 3/4" x 4 1/2" [69mm x 114mm].
EFS-TUN 	Replacement Tunnel – Allows cables to be wrapped around from one module to another without having to run another dedicated line. Tunnels fits EFSB2 and EFSB4 wall boxes. Includes two (2) tunnel pieces.	EFS-MOS 	Device Plate – European device plate accepts up to [45mm x 67.5mm] Arteor device. Device plate dimensions: 2 3/4" x 4 1/2" [69mm x 114mm].
EFS-DIV 	Replacement Divider – Provides separation of services. Includes one (1) divider.	EFSB10-3/4-11/4 	Knockout Plate – Has one 3/4" and one 3/4"/1 1/4" concentric trade size knockout.
		EFSB10-2 	Knockout Plate – Has one 2" trade size knockout.

NOTES



Electrical Wiring Systems

60 Woodlawn Street
West Hartford, CT 06110
Phone: 1.877.BY.LEGRAND (295-3472)
www.legrand.us

570 Applewood Crescent
Vaughan, Ontario L4K 4B4
Phone: 905.738.9195
www.legrand.ca

ED1707R1 – Updated August 2013 – For latest specs visit www.legrand.us/wiremold



Evolution™ Series Boxes...now available for walls

Evolution™ Series Wall Boxes are the latest advancement in the most innovative line of pathways in the industry. These wall boxes are designed for new work and old work applications while offering a sleek, clean look that architects will love and the functionality engineers and contractors require. Offered in a 2-gang version with a storage module for active A/V equipment and a 4-gang version when more power, communications, and A/V capacities are required, Evolution Series Wall Boxes are ideal for areas with large or small capacity needs. Evolution Series Wall Boxes are ideal for any area where a flat screen is required, such as: conference rooms, airports, entertainment venues, college campuses, and hospitals.

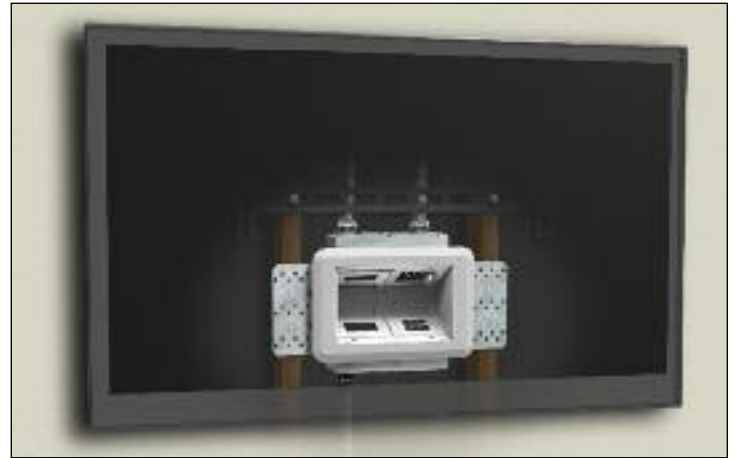

EFSB4 installed behind a flat screen display.

FEATURES & BENEFITS

■ **New work and old work applications.** Evolution Series Wall Boxes have been design to be able to be installed in both new work and old work installations. Saving time and money on the jobsite.

■ **Removable modules.** Removable modules facilitate quick and easy installations by allowing service feeds to be connected outside the box, increasing jobsite productivity and reducing overall project cost.



■ **Storage module.** The 2-gang Evolution Series Wall Box comes complete with a built-in storage module, large enough to hold the smaller receivers, and controllers that are typically found behind flat screen monitors.



■ **Available options.** Evolution Series Wall Boxes are available in both a 2-gang and a 4-gang version, allowing for maximum flexibility to fit the capacity needs of the task at hand.



■ **Finished cover.** Evolution Series Wall Boxes come complete with a decorative cover option that is field-paintable allowing the product to blend in and match the room decor.



■ **Low Profile Cover.** The decorative trim flange and cover are low profile (less than 1/4" from the wall surface) allowing the monitors to seat closer to wall.



FEATURES & BENEFITS (continued)

- **Built in Tunnel:** The built in tunnel allows services to be wrapped around, increasing flexibility and configurability, while reducing the number of service feeds that need to be brought to the box.

Tunnel

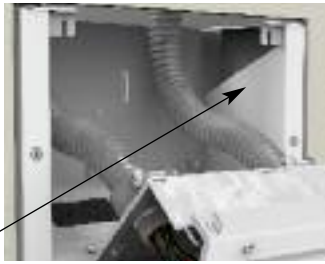

- **Feed Through Capability.** Between the removable modules and the tunneling feature, the Evolution Series Wall Boxes allows for service feeds to be fed through the boxes, reducing the number of feeds required, saving time and money.



- **Accepts standard size wall plates.** Each of the wall boxes are designed to accept standard size (2 3/4" x 4 1/2") [70mm x 114mm] device plates. No proprietary plates means quicker and easier installations.



- **Wiring Capacity:** 3 5/8" [92mm] of space behind the device plate allows for a maximum amount of space for wiring deeper A/V devices.

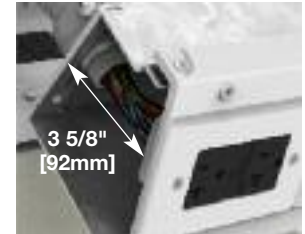

- **Finished interior.** Fully finished interior removes the unfinished industrial look while increasing visibility, making it easier to see where to plug in devices.



- **Plug-in Capacity.** 4 1/2" [114mm] of space between devices allows the end user to be able to easily plug into the active devices that are across from one another.

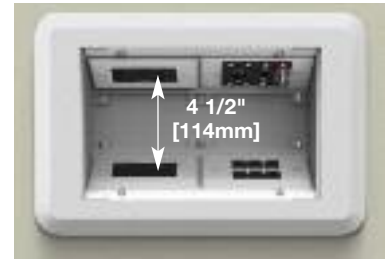

- **Multiple size knockouts.** All of the Evolution Series Wall boxes can accept service feeds from 3/4" trade size up to 2" trade size. These knockout plates are removable and interchangeable, providing the most flexibility and configurability options possible.



- **Datacom connectivity options.** Accepts industry standard and proprietary devices from a wide range of manufacturers to provide a seamless and aesthetically pleasing interface for voice, data and video applications at the point-of-use. A wide selection of data and adapter options are available for use with Ortronics® TracJack and Series II devices.

- **UL Listed to U.S. and Canadian safety standards.**

- **Removable Dividers.** Each module is supplied with one divider that can be removed and replaced when needed. Removable dividers allow for maximum configurability.

- **2" x 4" wall cavity.** The Evolution Series Wall Boxes are designed to fit within a standard 2"x 4" [51mm x 102mm] (metal or wood) wall cavity.

Evolution Series Floor Box Included Components

- KEY:**
- A. Main Body
 - B. Mounting Bracket
 - C. Tunnel
 - D. Device Module
 - E. Storage Module
 - F. Trim Flange
 - G. Decorative Cover

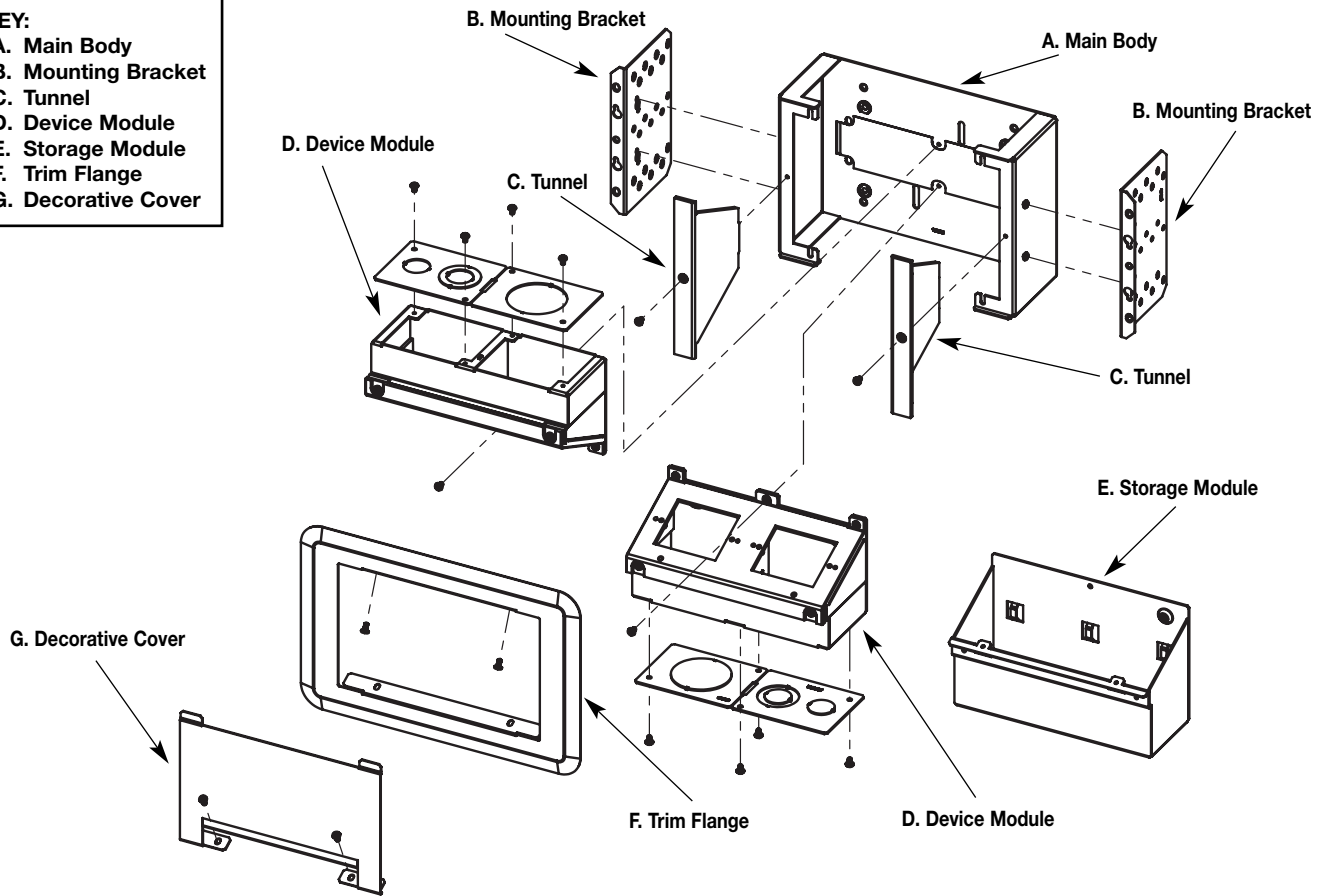

Evolution Series Wall Box Model Selection Guide

EVOLUTION WALL BOX MODEL	EFSB2	EFSB4
INSTALL TYPE: New Work Old Work	YES YES	
BOX CAPACITY:	2-Gangs	4-Gangs
DEPTH BEHIND PLATES:	3 5/8" [92mm]	
REMOVABLE MODULES:	YES	
DEVICE PLATE SIZE:	Uses Standard Size Device Plates: Single-Gang (2 3/4" x 4 1/2") [70mm x 114mm]	
COVER COLORS:	White	
COMPARTMENT VOLUMES:	43 cubic inches [705ml]	43 cubic inches [705ml]
KO SIZE RANGE: (Trade Size)	3/4" to 2"	
TUNNELS:	YES	
NOTES:	Trim flange and decorative cover are paintable	

Evolution Series EFSB2 Wall Box Ordering Information

Catalog No./Item

Description/Specifications

EFSB2

2-Gang Wall Box – Designed to fit and be concealed behind 42" [1.067m] or larger flat screen displays. Can be installed in both new work and old work applications. Has 2 NEMA size openings for power, communication, or A/V devices. Box is also equipped with a storage module that will accept active A/V equipment up to 6 7/8" x 9 1/8" [175mm x 232mm] (dimensions include wire and cables) in size.

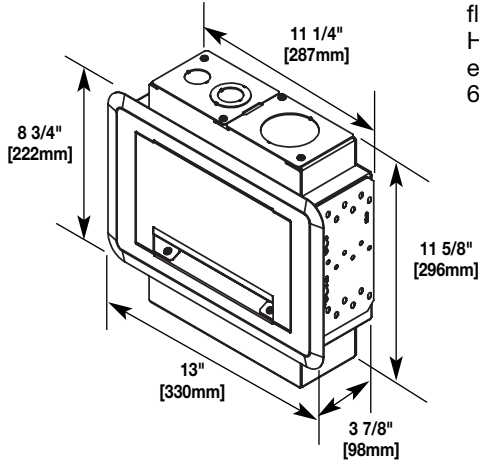

Components Included:

- A** Box Body
- B** Mounting Brackets (2)
- C** Tunnel (2)
- D** Device Module
- E** Storage Module
- F** Trim Flange
- G** Decorative Cover

Each Module Consists of:

- One (1) Device Bracket
- One (1) Back Box
- One (1) Removable Divider
- One (1) EFS-DIV Divider
- 3/4"-1 1/4" Removable KO Plate
- 2" Removable KO Plate

Items not included with the box and sold separately:

- Receptacles
- Communication Jacks
- A/V Devices
- Device plates

EFSB2 Exploded View

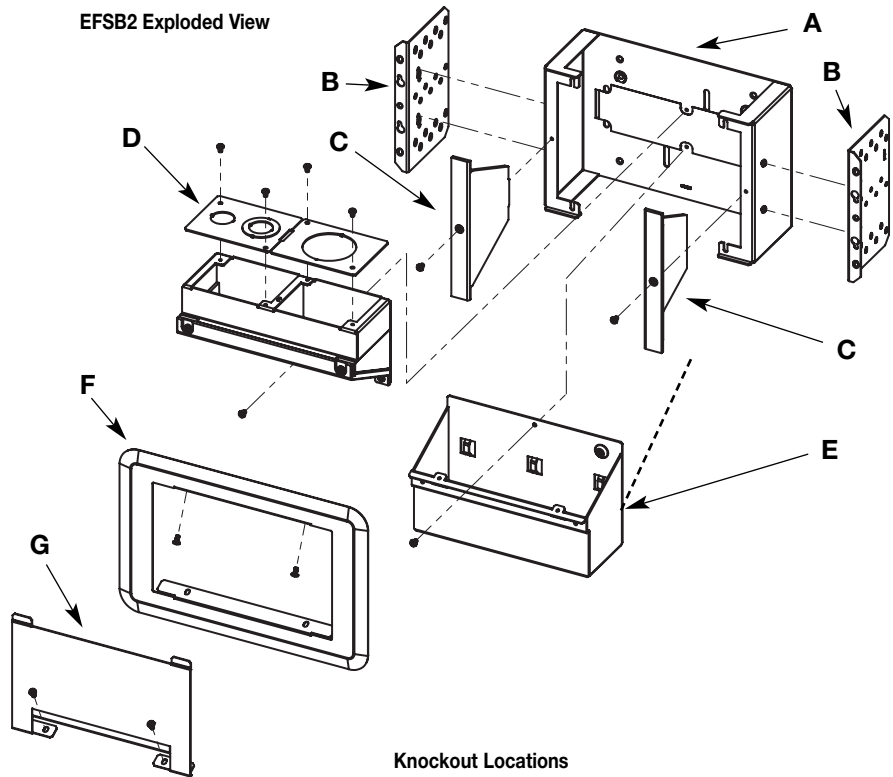

Device Module

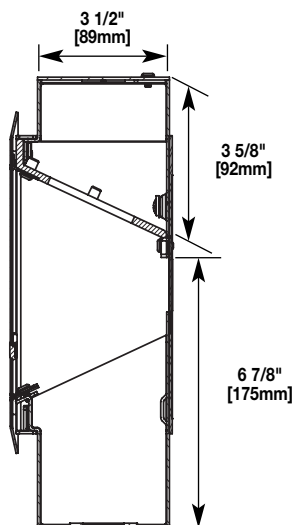

Knockout Locations

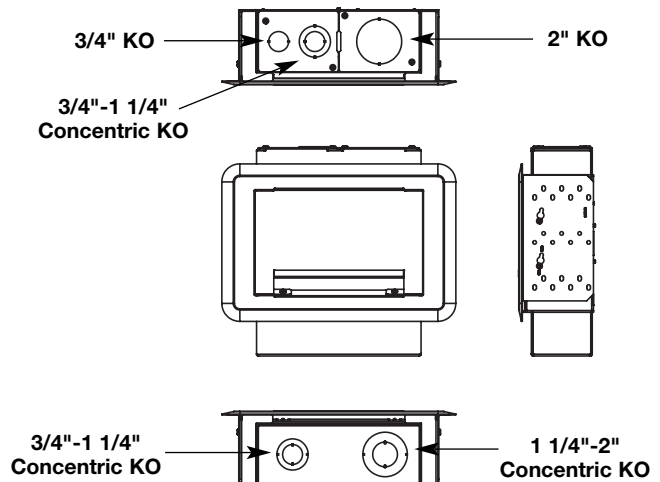

Evolution Series EFSB4 Wall Box Ordering Information

Catalog No./Item

Description/Specifications

EFSB4

4-Gang Wall Box – Designed to fit and be concealed behind 42" [1.067m] or larger flat screen displays. Can be installed in both new work and old work applications. Has 4 NEMA size openings for power, communication, or A/V devices.

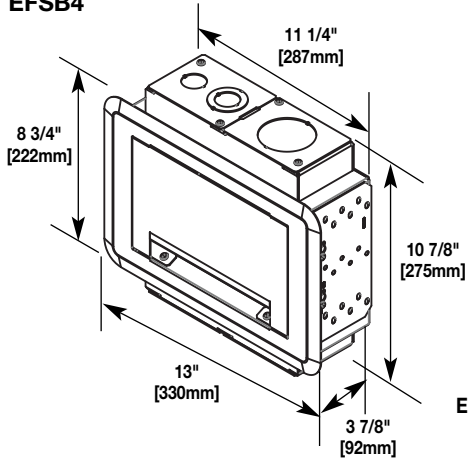

Components Included:

- A** Box Body
- B** Mounting Brackets (2)
- C** Tunnel (2)
- D** Device Modules (2)
- E** Trim Flange
- F** Decorative Cover

Each Module Consists of:

- One (1) Device Bracket
- One (1) Back Box
- One (1) Removable Divider
- One (1) EFS-DIV Divider
- 3/4"-1 1/4" Removable KO Plate
- 2" Removable KO Plate

Items not included with the box and sold separately:

- Receptacles
- Communication Jacks
- A/V Devices
- Device plates

EFSB4 Exploded View

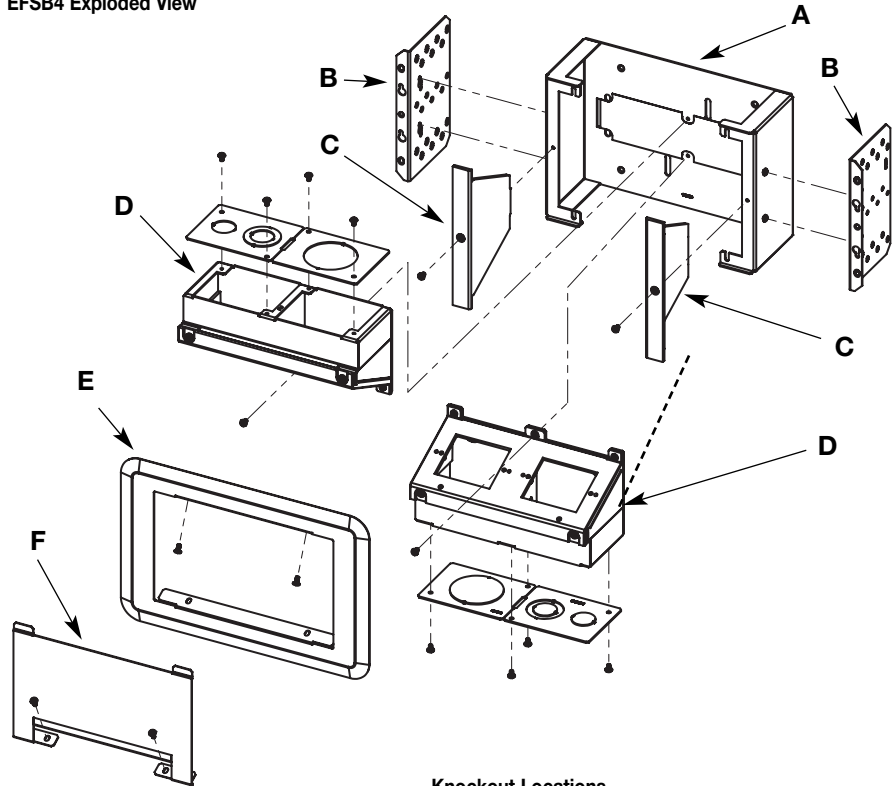



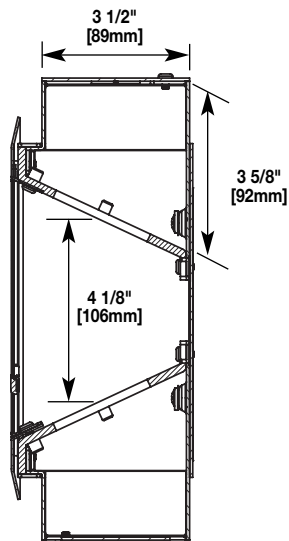

Device Module

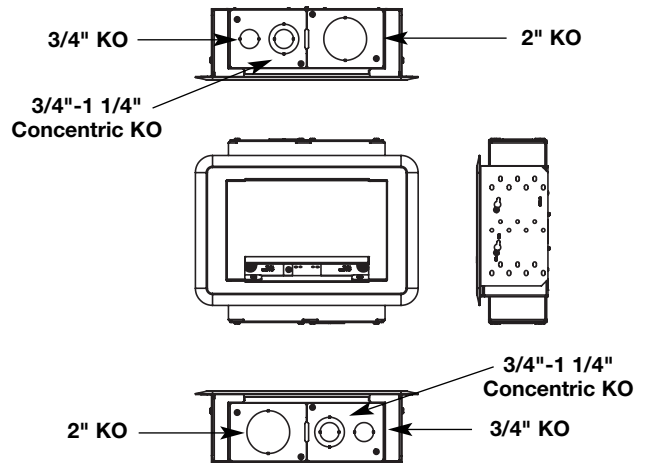

Knockout Locations

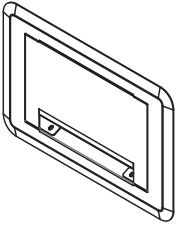
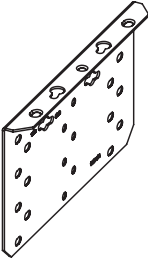
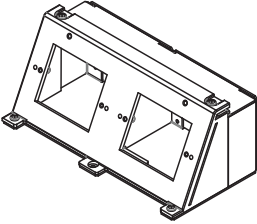

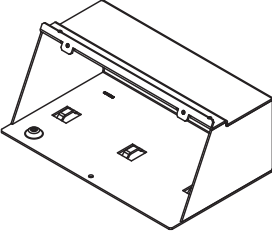
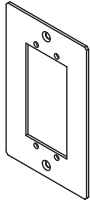
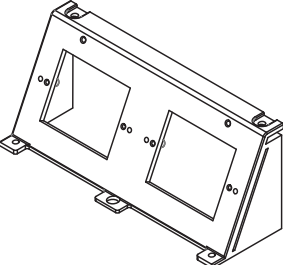
Evolution Series Wall Box Replacement Parts & Accessories Ordering Information

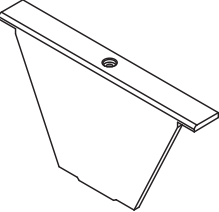
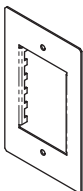
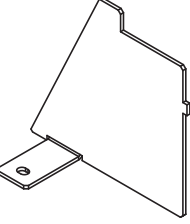
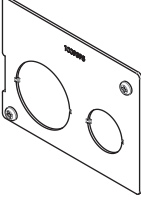
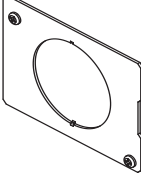
Catalog No./Item	Description/Specifications	Catalog No./Item	Description/Specifications
EFS-C 	Replacement Trim Flange & Cover Assembly – Replacement trim flange and decorative cover assembly for the EFSB2 and EFSB4 wall boxes. Trim flange and cover are finished in a decorative white color, with a paintable surface to match any room decor.	EFS-MB 	Replacement Mounting Bracket – Allows wall box to be secured to wall in both new work and old work applications. Includes 2 brackets.
EFS-DM 	Replacement Device Module – Comes complete with module base, 2" trade size knockout plate, 3/4" and 3/4" / 1-1/4" concentric knockout plate, and a removable divider. Finished in a decorative white color.	EFB-B 	Blank Device Plate – Device plate dimensions: 2 3/4" x 4 1/2" [69mm x 114mm].
EFS-SM 	Replacement Storage Module – Used to store active A/V equipment. Comes complete with tie-down locations to secure devices in place. Decorative white finish. Includes one (1) storage module.	EFB-AAP 	Device Plate – holds two (2) Extron® Electronics AAP devices. Device plate dimensions: 2 3/4" x 4 1/2" [69mm x 114mm].
EFS-DB 	Replacement 2-Gang Device Bracket – Each location is sized to accept NEMA standard devices. Device bracket will fit both the EFSB2 and EFSB4 wall boxes. Includes one (1) bracket.	EFB-MAAP 	Device Plate – holds four (4) Extron® Electronics MAAP devices. Device plate dimensions: 2 3/4" x 4 1/2" [69mm x 114mm].
EFS-TUN 	Replacement Tunnel – Allows cables to be wrapped around from one module to another without having to run another dedicated line. Tunnels fits EFSB2 and EFSB4 wall boxes. Includes two (2) tunnel pieces.	EFB-MOS 	Device Plate – European device plate accepts up to [45mm x 67.5mm] Arteor device. Device plate dimensions: 2 3/4" x 4 1/2" [69mm x 114mm].
EFS-DIV 	Replacement Divider – Provides separation of services. Includes one (1) divider.	EFB810-3/4-11/4 	Knockout Plate – Has one 3/4" and one 3/4"/1 1/4" concentric trade size knockout.
		EFB810-2 	Knockout Plate – Has one 2" trade size knockout.

NOTES



Electrical Wiring Systems

60 Woodlawn Street
West Hartford, CT 06110
Phone: 1.877.BY.LEGRAND (295-3472)
www.legrand.us

570 Applewood Crescent
Vaughan, Ontario L4K 4B4
Phone: 905.738.9195
www.legrand.ca

ED1707R1 – Updated August 2013 – For latest specs visit www.legrand.us/wiremold

