

<b>Contents</b>	<b>Page</b>
Standards . . . . .	1
General Information . . . . .	2-3
Electrical Characteristics/ Technical Data . . . . .	4-9
Electronic Trip Units . . . . .	10-12
Catalogue Numbers/ Termination Accessories	
G-Frame, 16-100 Amperes . . . . .	13
E-Frame, 16-225 Amperes . . . . .	14-15
J-Frame, 100-250 Amperes . . . . .	16-17
K-Frame, 63-400 Amperes . . . . .	18-19
L-Frame, 315-800 Amperes . . . . .	20-21
N-Frame, 400-1250 Amperes . . . . .	22-25
R-Frame, 800-2500 Amperes . . . . .	26-29
Motor Circuit Protectors . . . . .	30
Frame Sizes G through R . . . . .	31-32
Handle Mechanisms . . . . .	33-35
Accessories and Modifications . . . . .	36-38
Time-Current Curves . . . . .	39-40
Current Limiting Curves . . . . .	41
Dimensions . . . . .	42-43
Sales Offices . . . . .	44
Typical Specifications . . . . .	Inside Back Cover

**Standards**

Cutler-Hammer Moulded Case Circuit Breakers are designed to conform with the following international standards:

- Australian Standard AS 2184 and AS 3947-2 Moulded Case Circuit Breakers.
- British Standards Institution Standard BS 4752: Part 1, Switchgear and Control Gear Part 1, Circuit Breakers.
- International Electrotechnical Commission Recommendations IEC 60947.2 Circuit Breakers. 
- Japanese T-Mark Standard Moulded Case Circuit Breakers.
- National Electrical Manufacturers Association Standards Publication No. AB1-1975 Moulded Case Circuit Breakers.
- South African Bureau of Standards, Standard SABS 156, Standard Specification for Moulded Case Circuit Breakers.
- Swiss Electro-Technical Association Standard SEV 947.2, Safety Regulations for Circuit Breakers.
- Union Technique de l'Electricite Standard NF C 63-120, Low Voltage Switchgear and Control Gear Circuit Breaker Requirements.
- Verband Deutscher Elektrotechnike (Association of German Electrical Engineers) Standard VDE 0660, Low Voltage Switchgear and Control Gear, Circuit Breakers.

**Global Third Party Certification**

Certification marks assure product compliance with the total standard via the third party witnessing of tests by globally recognized independent certification organizations.

KEMA is a highly recognized, completely independent international organization that offers certification and inspection facilities for equipment in many industries. The KEMA-KEUR mark is the highest certification an electrical product can receive from KEMA. Our IEC 60947-2 Moulded Case Circuit Breakers are KEMA tested and certified.

What does the KEMA-KEUR rating mean for you? It means an independent testing house. KEMA Registered Quality has tested and certified these products to IEC 60947-2 standards. In addition, KEMA is conducting ongoing follow-up witness test programs to assure IEC 60947-2 compliance to maintain the KEMA Certification mark, KEMA-KEUR has been a well-known and highly respected independent mark for over 70 years, a symbol of quality assurance that enjoys the confidence of both manufacturers and consumers.

Cutler-Hammer also offers a complete line of Moulded Case Circuit Breakers, UL listed in accordance with UL 489 as well as CSA C22.2 No. 5.1 certified are also available. Both UL and CSA are independent third party testing houses that continue to assure that Cutler-Hammer Moulded Case Circuit Breakers meet their exacting standards through regularly scheduled follow-up testing and inspections.

## Cutler-Hammer Frame Sizes G through R

### General Information

Cutler-Hammer Moulded Case Circuit Breakers provide increased performance in considerably less space than standard circuit breakers or comparable fusible devices. Reduced system costs can also be realized because Cutler-Hammer Circuit Breakers are used in series rated systems, allowing the use of lower interrupting circuit breakers downstream.

Cutler-Hammer Circuit Breakers meet applicable IEC 60947-2 standards, have been assigned ultimate and service interrupting ratings per IEC 60947-2, and employ adjustable thermal and adjustable magnetic trips.

The Cutler-Hammer family includes seven frame sizes in ratings from 100 to 2500 amperes. Each frame size offers a choice of several interrupting capacities up to 100 kA at 415 volts ac (200 kA at 240 volts ac). This provides greater design flexibility than ever before possible while also helping to save space.

Cutler-Hammer Circuit Breakers virtually eliminate the need for redesign and they can be used to replace older circuit breakers in the same panelboards, feeder pillars, busbar trunking tap-offs, individual enclosures, machine tool control panels, and motor control centres. In most cases, the same connecting straps, studs, and handle mechanisms can be retained and used.

Standard calibration is 40°C. For applications in high ambient temperature conditions, 50°C factory calibration is available.

Cutler-Hammer Circuit Breakers are also provided for dc applications. Interrupting ratings of 35 kA for the 600 ampere frame have been achieved for three-pole breakers in series at 600 volts dc.

### The Most Logically Designed Contact Assembly

The flexibility and outstanding performance characteristics of Cutler-Hammer Circuit Breakers are made possible by one of the most logically designed contact assemblies in circuit breaker history. Based on previously patented Westinghouse contact conductor designs, the Cutler-Hammer contact assembly creates a high-speed "blow-open" action when it confronts the electromechanical forces produced by high-level fault currents.

Cutler-Hammer Circuit Breakers are operated by a toggle-type handle that is mechanically trip-free from the handle so that the contacts cannot be held closed against short circuit currents. Tripping due to overload or short circuits is clearly indicated by the position on the handle. This remarkably fast and dependable contact action is designed to enhance safety.

### Thorough In-Plant Testing

The quality, dependability, and reliability of every Cutler-Hammer Circuit Breaker is assured by a thorough program of in-plant testing. Two calibration tests are conducted on every pole of every circuit breaker to verify the trip mechanism, operating mechanism, continuity, and accuracy.

### ISO Certification

Cutler-Hammer Circuit Breakers are manufactured in ISO certified facilities.

### More Interrupting Capacity in Less Space

Cutler-Hammer Circuit Breakers are physically and electrically interchangeable with the "Classic" standard line of Westinghouse moulded case circuit breakers. This means Cutler-Hammer Breakers are ideal for upgrading equipment designs and retrofitting existing installations.

### Current Limiting Characteristics

All Cutler-Hammer Circuit Breakers are current limiting because of their high repulsion contact arrangement and incorporation of state-of-the-art arc extinguishing technology.

### Operating Mechanisms

Cutler-Hammer Circuit Breakers have, in their basic version, a toggle handle operating mechanism, which also serves as switching position indicator. As well as ON and OFF, the further position TRIPPED is possible.

The toggle handle snaps into the TRIPPED position if the breaker is tripped by one of its overcurrent, short circuit, shunt or undervoltage releases. Before the circuit breaker can be reclosed following a trip-out, the toggle handle must be brought beyond the OFF position (RESET). The circuit breaker can then be reclosed.

As an additional switching position indicator for F- to R-Frame circuit breakers, there are two windows on the right and on the left of the toggle handle, in which the switching state is indicated by means of the colours red, green and white corresponding to the ON, OFF and TRIPPED positions respectively.

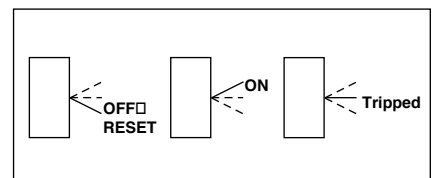

Positions of the Toggle Handle Drive

### Cutler-Hammer Frame Sizes G through R

#### Panelboards

As both main and branch circuit protection devices (G-, E-, J-, K-, L- and N-Frames).

#### Feeder Pillars

In distribution systems to provide main and branch circuit protection (E-, J-, K-, L-, N- and R-Frames).

#### Switchgear

In distribution systems to provide main and branch circuit protection up to 2500 amperes (R-Frame).

#### Busbar Trunking Tap-Offs

In busbar trunking tap-offs to provide branch circuit protection (F-Frame); and to provide feeder or branch circuit protection (J-, K- and L-Frames).

#### Individual Enclosures

Completely assembled in enclosures to meet specific customer requirements (G-, E-, J-, K-, L-, N- and R-Frames).

#### Machine Tool Control Panels and Motor Control Centres

Applied for specific equipment requirements (G-, E-, J-, K-, and L-Frames).

#### Additional Applications

Special versions of each Cutler-Hammer frame are available to provide safe equipment control and protection in mining and other applications. Contact your Cutler-Hammer agent or distributor for additional information.

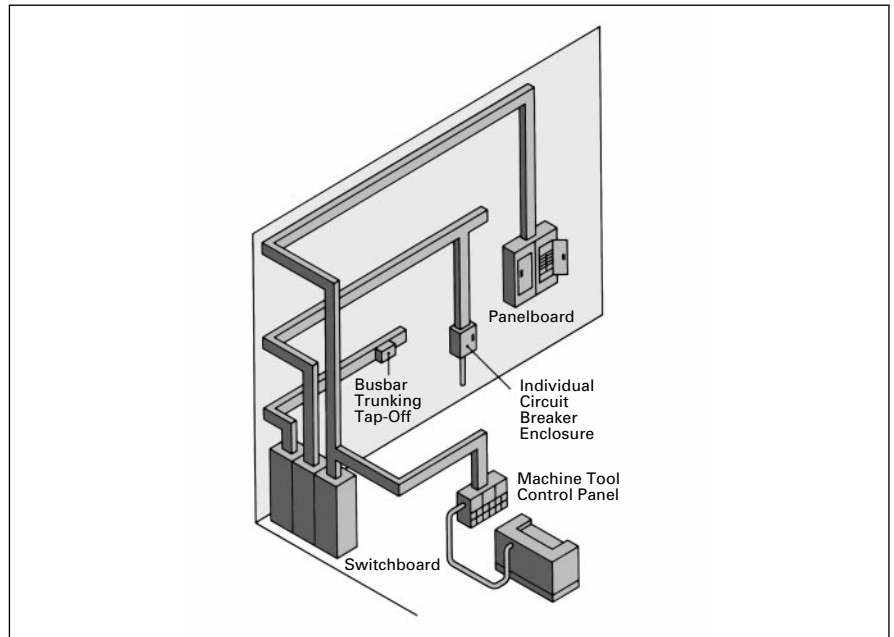





Typical Cutler-Hammer Applications

Frame	Continuous Ampere Rating Range	Type of Trip Unit					Moulded Case Switch
		Adjustable Thermal Fixed Magnetic	Fixed Thermal Fixed Magnetic	Adjustable Thermal Adjustable Magnetic	Adjustable Thermal Fixed Magnetic Earth Leakage	Digitrip RMS Electronic Trip Units	
G	16-100	–	■	–	–	–	■
E	16-125	■	■	–	–	–	■
J	125-250	–	–	■	■	–	■
K	63-400	–	–	■	■	■	■
L	315-800	–	–	■	–	■	■
N	400-1250	–	–	–	–	■	■
R	800-2500	–	–	–	–	■	■

## Cutler-Hammer Frame Sizes G through J

## Electrical Characteristics

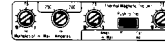
		G			E						J			
														
<b>Maximum Rated Current (Amperes)</b>		100			125						250			
<b>Breaker Type</b>		GWF <sup>②</sup>		GWF <sup>②</sup>	B	E	S	H	E	S	H			
<b>Breaker Capacity (kA rms) AC 50-60 Hz</b>														
IEC 60947-2	220-240 VAC	$I_{CU}$	18	65	25	25	35	85	85	100	100	65	85	100
		$I_{CS}$	9	33	25	25	35	43	43	50	50	65	85	100
	380-415 VAC	$I_{CU}$	—	25	—	18	25	—	40	—	70	25	40	70
		$I_{CS}$	—	13	—	18	25	—	30	—	35	25	40	70
	660-690 VAC	$I_{CU}$	—	—	—	—	—	—	—	—	—	12	12	14
		$I_{CS}$	—	—	—	—	—	—	—	—	—	6	6	7
	250 VDC <sup>③</sup>	$I_{CU}$	—	10	10	10	10	35	35	42	42	10	22	22
		$I_{CS}$	—	5	10	10	10	35	35	42	42	10	22	22
NEMA	240 VAC	18	65	25	25	35	85	85	100	100	65	85	100	
	480 VAC	—	22	—	18	25	—	35	—	65	25	35	65	
	600 VAC	—	—	—	—	—	—	—	—	—	18	25	35	
<b>Number of Poles</b>		1	2, 3	1	2, 3, 4	2, 3, 4	1	2, 3, 4	1	2, 3, 4	2, 3, 4			
<b>Ampere Range</b>		16-125A			16-125A						63-250A			
<b>Trip Units</b>											 <b>Adjustable Thermal Magnetic</b>  <b>Adjustable Thermal Magnetic</b>			
		Interchangeable	—			—						■		
		Built-in	■			■						■		
<b>Thermal Magnetic</b>	Fixed Thermal	■			■						■			
	Adjustable Thermal	Fixed			■						■			
	Magnetic	Fixed			Fixed						Adjustable			
<b>Solid State rms<sup>③</sup></b>	LS	—			—						—			
	LSI	—			—						—			
	LSG	—			—						—			
	LSIG	—			—						—			
<b>Dimensions (mm)</b>	1-Pole	H	123.8	254.4	66.7	139.7	W	25.4	76	177.8	105	103	103	
		2-Pole	50.8	50.8										
		3-Pole	76.2	76.2										
		4-Pole	—	101.6										
	4-Pole	—	—	—	—	—	—	—	—	—	140	—	—	
<b>Weight (approximate) Kgs.</b>		1-Pole	2-Pole	3-Pole	1-Pole	2-Pole	3-Pole	4-Pole	2-Pole	3-Pole	4-Pole			
		0.4	0.7	1	0.45	0.91	1.36	1.81	5.2	5.2	7.0			





① 2 poles in series.

② Not KEMA-KEUR listed. R-frame scheduled for 2001.

③ Not suitable for DC application. 4-pole ground fault not available.

Cutler-Hammer Frame Sizes K through L

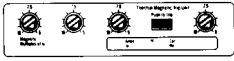
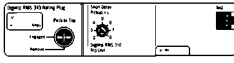
Electrical Characteristics

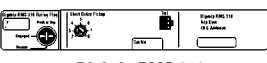
		K				L			
									
Maximum Rated Current (Amperes)		400				630			
Breaker Type		KW	HKW	KWC <sup>①</sup>	LW	HLW	LWC <sup>①</sup>	LW	
<b>Breaker Capacity (kA rms) AC 50-60 Hz</b>									
IEC 947-2	220-240 VAC	I <sub>CU</sub>	85	100	200	85	100	200	65
		I <sub>CS</sub>	85	100	150	85	100	150	33
	380-415 VAC	I <sub>CU</sub>	45	70	100	45	70	100	50
		I <sub>CS</sub>	45	70	75	45	70	75	25
	660-690 VAC	I <sub>CU</sub>	20	25	35	20	25	35	20
		I <sub>CS</sub>	10	13	18	10	13	18	10
250 VDC <sup>②</sup>	I <sub>CU</sub>	10	20	20	20	20	20	20	
	I <sub>CS</sub>	5	10	10	10	10	10	10	
NEMA	240 VAC	65	100	200	65	100	200	65	
	480 VAC	35	65	100	35	65	100	35	
	600 VAC	25	35	50	25	35	50	25	
Number of Poles		2, 3, 4				2, 3, 4			
Ampere Range		63-400A				315-630A			
Trip Units		 Adjustable Thermal Magnetic  Digitrip RMS 310				 Adjustable Thermal Magnetic  Digitrip RMS 310			
Interchangeable		■				■			
Built-in		■				■			
Thermal Magnetic	Fixed Thermal	■				■			
	Adjustable Thermal	■				■			
	Magnetic	Adjustable				Adjustable			
Solid State rms <sup>②③</sup>	LS	Standard				Standard			
	LSI	Optional				Optional			
	LSG	Optional <sup>③</sup>				Optional			
	LSIG	Optional <sup>③</sup>				Optional			
Dimensions (mm)		H	W	D	H	W	D		
	1-Pole	—	—	—	—	—	—		
	2-Pole	—	—	—	—	—	—		
	3-Pole	258	140	104	630A = 273 800A = 406	210	104		
4-Pole		183			280				
Weight (approximate) Kgs.		3-Pole		4-Pole		3-Pole		4-Pole	
		6.1		7.3		630A = 9.4/800A = 11.3		630A = 11.1/800A = 14.4	

① Not KEMA-KEUR listed. R-frame scheduled for 2001.

② 2 poles in series.

③ Not suitable for DC application. 4-pole ground fault not available.

## Cutler-Hammer Frame Sizes N and R

### Electrical Characteristics

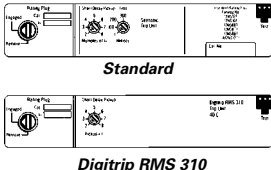
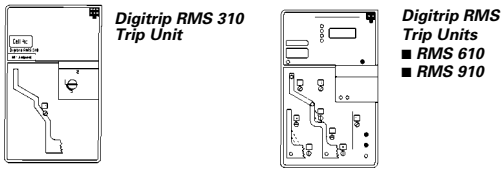
		N				R			
<b>Maximum Rated Current (Amperes)</b>		800, 1250				1600	1600, 2000, 2500		
<b>Breaker Type</b>		NW	HNW	NWC <sup>①</sup>	NW	RW <sup>①</sup>		RWC <sup>①</sup>	
<b>Breaker Capacity (kA rms) AC 50-60 Hz</b>									
IEC 947-2	220-240 VAC	$I_{CU}$	85	100	200	85	135	200	
		$I_{CS}$	85	100	100	85	100	100	
	380-415 VAC	$I_{CU}$	50	70	100	50	70	100	
		$I_{CS}$	50	50	50	50	50	50	
	660-690 VAC	$I_{CU}$	20 <sup>②</sup>	25 <sup>②</sup>	35	20 <sup>②</sup>	25	35	
		$I_{CS}$	10	13	18	10	13	18	
250 VDC <sup>③</sup>	$I_{CU}$	—	—	—	—	—	—		
	$I_{CS}$	—	—	—	—	—	—		
NEMA	240 VAC	65	100	200	100	125	200		
	480 VAC	50	65	100	65	65	100		
	600 VAC	25	35	50	35	50	65		
<b>Number of Poles</b>		2, 3, 4				3	3, 4		
<b>Ampere Range</b>		400-1250A				1600A	800-2500A		
<b>Trip Units</b>		 <p>Standard Digitrip RMS 310</p>				 <p>Digitrip RMS 310 Trip Unit Digitrip RMS Trip Units ■ RMS 610 ■ RMS 910</p>			
Interchangeable		—				—			
Built-in		■				■			
Thermal Magnetic	Fixed Thermal	—				—			
	Adjustable Thermal	—				—			
	Magnetic	—				—			
Solid State rms <sup>④</sup>	LS	Standard				Standard (LI is Optional in Digitrip 510, 610, 810 and 910)			
	LSI	Optional				Optional			
	LSG	Optional				Optional (LIG is Optional in Digitrip 510, 610, 810 and 910)			
	LSIG	Optional				Optional			
Dimensions (mm)	1-Pole	H	W	D	H	W	D		
		—	—	—	—	—	—	—	
	2-Pole	—	—	—	—	—	—	—	
		—	—	—	—	—	—	—	
3-Pole	406	210	104	406	394	229			
4-Pole	—	280	—	—	508	—			
Weight (approximate) Kgs.	3-Pole	4-Pole		3-Pole		4-Pole			
		21.3	28.3	47	54				

① Not KEMA-KEUR listed. R-frame scheduled for 2001.

② IEC 60947-2 H.5 Annex H is not KEMA-KEUR tested.

③ 2 poles in series.

④ Not suitable for DC application. 4-pole ground fault not available.

Cutler-Hammer Frame Sizes G through R

Electrical Characteristics

Technical Data	G-Frame	E125-Frame	J250-Frame	K-Frame	L-Frame	N-Frame	R-Frame
Maximum Rated Current I <sub>n</sub> Depending on the Version	100A	125A	200/250A	315/400A	500/630/800A	800/1250A	1600/2000/2500A
Rated Insulation Voltage U <sub>i</sub> , According to IEC 947-2 Main Conducting Paths Auxiliary Circuits	1-Pole = 250 VAC 2,3-Pole = 415 VAC 690 VAC	750 VAC 690 VAC	750 VAC 690 VAC	750 VAC 690 VAC	750 VAC 690 VAC	750 VAC 690 VAC	750 VAC 690 VAC
Rated Impulse Withstand Voltage U <sub>imp</sub> Main Conducting Paths Auxiliary Circuits	1-Pole = 4 kV 2,3-Pole = 6 kV 4 kV	6 kV 4 kV	8 kV 4 kV	8 kV 4 kV	8 kV 4 kV	8 kV 4 kV	8 kV 4 kV
Rated Operational Voltage U <sub>e</sub> IEC NEMA	440 VAC 480 VAC	440 VAC 600Y/347 VAC	690 VAC 600 VAC	690 VAC 600 VAC	690 VAC 600 VAC	690 VAC 600 VAC	690 VAC 600 VAC
Permissible Ambient Temperature	-20 to +70°C	-20 to +70°C	-20 to +70°C	-20 to +70°C	-20 to +70°C	-5 to +60°C	-5 to +60°C
Permissible Load for Various Ambient Temperatures Close to the Circuit Breaker, Related to the Rated Current of the Circuit Breaker ■ Circuit Breakers for Plant Protection - At 40°C - At 50°C - At 55°C - At 60°C - At 70°C ■ Circuit Breakers for Motor Protection - At 40°C - At 50°C - At 55°C - At 60°C - At 70°C ■ Circuit Breakers for Starter Combinations and Isolating Circuit Breakers - At 40°C - At 50°C - At 55°C - At 60°C - At 70°C	- 100% 96% 93% 91% 86%	① ② 100% 100% 96% 92% 93% 87% 91% 83% 86% 73%	① ② 100% 100% 96% 94% 94% 90% 92% 87% 88% 80%	① ② 100% 100% 96% 92% 93% 87% 90% 84% 85% 75%	① ② 100% 100% 96% 91% 93% 86% 90% 82% 84% 70%	- 100% 91% 85% 81% -	- 100% 100% 100% 100% -
Rated Short Circuit Breaking Capacity (DC) Not for Circuit Breakers for Motor Protection (Time Constant τ = 10 rms) 1 Conducting Path 2 Conducting Paths in Series 3 Conducting Paths in Series For F to L up to: 250 VDC 440 VDC 660 VDC NEMA (Time Constant τ = 8 rms) 1 Conducting Path 2 Conducting Paths in Series 250 VDC - 250 VDC	- 10 kA (5 rms)	20 kA Max. 10 kA 22 kA	20 kA Max. 10 kA 22 kA	20 kA Max. 10 kA 22 kA	20 kA Max. 10 kA 22 kA	-③ -③ -③	-③ -③ -③
Main Switch Characteristics According to IEC 947-2 in Combination with Lockable Rotary Drives	-	Yes	Yes	Yes	Yes	Yes	Yes
Rated Short Circuit Breaking Capacity According to IEC 947-2 (at AC 50/60 Hz)	Rated Short Circuit Breaking Capacity See Table on Pages 4-5-6						
Endurance (Operating Cycles)	10,000	10,000	10,000	8,000	8,000	3,000	3,000
Maximum Switching Frequency	300 1/h	300 1/h	240 1/h	240 1/h	240 1/h	60 1/h	20 1/h
Conductor Cross Sections and Terminal Types for Main Conductors ■ Solid or Stranded ■ Finely Stranded with End Sleeve ■ Busbar Tightening Torque for Box Terminals Tightening Torque for Busbar Connection Pieces	Box Terminals 2.5 to 50 mm <sup>2</sup> - 5.1 Nm -	Box Terminals 2.5 to 95 mm <sup>2</sup> 2.5 to 50/70 mm <sup>2</sup> 4/6 Nm 4.5 Nm	Box Terminals 50 to 150 mm <sup>2</sup> 35 to 120 mm <sup>2</sup> - 20 Nm 15 Nm	Box Terminals 95 to 240 mm <sup>2</sup> 70 to 150 mm <sup>2</sup> - 42 Nm 30 Nm	Flat Bar Terminals - 800A 31 Nm 6 Nm	Flat Bar Terminals - - Optional 31 Nm 50 Nm	Flat Bar Terminals - - Optional - 37 Nm
Conductor Cross Sections for Auxiliary Circuits with Terminal Connection or Terminal Strip ■ Solid ■ Finely Stranded with End Sleeve ■ With Brought-out Cable Ends ■ Tightening Torque for Fitting Screws	0.75 to 2.5 mm <sup>2</sup> 0.75 to 2.5 mm <sup>2</sup> - -	0.75 to 2.5 mm <sup>2</sup> 0.75 to 2.5 mm <sup>2</sup> - -	0.75 to 2.5 mm <sup>2</sup> 0.75 to 2.5 mm <sup>2</sup> 0.82 (AWG 18) mm <sup>2</sup> 0.8 to 1.4 Nm	0.75 to 2.5 mm <sup>2</sup> 0.75 to 2.5 mm <sup>2</sup> 0.82 (AWG 18) mm <sup>2</sup> 0.8 to 1.4 Nm	0.75 to 2.5 mm <sup>2</sup> 0.75 to 2.5 mm <sup>2</sup> 0.82 (AWG 18) mm <sup>2</sup> 0.8 to 1.4 Nm	Up to 2x4 mm <sup>2</sup> Up to 2x2.5 mm <sup>2</sup> 0.82 (AWG 18) mm <sup>2</sup> 0.8 to 1.4 Nm	Up to 2x4 mm <sup>2</sup> Up to 2x2.5 mm <sup>2</sup> 0.82 (AWG 18) mm <sup>2</sup> 0.8 to 1.4 Nm
Power Loss per Circuit Breaker at Maximum Rated Current I <sub>n</sub> (The Power Losses of the Undervoltage Releases ("r" Releases) Must Be Observed if Necessary) at Three-Phase Symmetrical Load ■ For Plant Protection ■ As Isolating Circuit Breaker ■ For Starter Combinations ■ For Motor Protection	50 W 40 W 40 W 50 W	50 W 40 W 40 W 50 W	75 W 75 W 45 W -	175 W 107 W 107 W 75 W	255 W 160 W 160 W 120 W	87/210 W 87/210 W - -	220/270/400 W 220/270/400 W - -
Permissible Mounting Position							

① Thermal overload release set to the lower value.

② Thermal overload release set to the upper value, respecting fixed-setting thermal overload releases.

③ Not suitable for DC switching.



## Cutler-Hammer Frame Sizes G through R

### Electrical Characteristics

Technical Data	G-Frame	E125-Frame	J250-Frame	K-Frame	L-Frame	N-Frame	R-Frame
<b>Auxiliary Switches</b>							
Rated Thermal Current $I_{th}$	6A	6A	6A	6A	6A	6A	6A
Rated Making Capacity	10A	20A	20A	20A	20A	20A	20A
AC (AC-15)							
– Rated Operational Voltage	240V	230/400/600V	230/400/690V	230/400/690V	230/400/690V	230/400/690V	230/400/690V
– Rated Operational Current	6A	6/3/0.25A	6/3/0.25A	6/3/0.25A	6/3/0.25A	6/3/0.25A	6/3/0.25A
DC (DC-13)							
– Rated Operational Voltage	24	24/125/250V	24/125/240V	24/125/240V	24/125/240V	24/125/240V	24/125/240V
– Rated Operational Current	5	6/0.5/0.25A	6/0.5/0.15A	6/0.5/0.15A	6/0.5/0.15A	6/0.5/0.15A	6/0.5/0.15A
Back-up Fuse	6A	6/4/4A	6/4/4A	6/4/4A	6/4/4A	6/4/4A	6/4/4A
Miniature Circuit Breaker	6A	6/4A	6/4A	6/4A	6/4A	6/4A	6/4A
<b>Releases</b>							
Undervoltage Releases ("r" Releases)							
Response Voltage:							
– Drop (Breaker Tripped) $U_s$	35-70%	35-70%	35-70%	35-70%	35-70%	35-70%	35-70%
– Pickup (Breaker May Be Switched on) $U_s$	85-110%	85-110%	85-110%	85-110%	85-110%	85-110%	85-110%
Power Consumption in Continuous Operation at:							
– AC 50/60 Hz 12V	–	0.95 VA	1.9 VA	1.9 VA	1.9 VA	1.9 VA	2.9 VA
– AC 50/60 Hz 24V	5.3 VA	0.72 VA	3.9 VA	3.9 VA	3.9 VA	2.4 VA	3.1 VA
– AC 50/60 Hz 48-60V	1.5 VA	1.15-1.78 VA	2.5-3.8 VA	2.5-3.8 VA	2.5-3.8 VA	2.3-4.1 VA	3.4-6.0 VA
– AC 50/60 Hz 110-127V	1.8 VA	0.96-1.25 VA	1.8-2.4 VA	1.8-2.4 VA	1.8-2.4 VA	3.4-4.2 VA	3.3-3.8 VA
– AC 50/60 Hz 208-240V	1.4 VA	1.28-1.68 VA	2.7-3.8 VA	2.7-3.8 VA	2.7-3.8 VA	4.8-6.5 VA	4.2-7.2 VA
– AC 50/60 Hz 380-500V	4.8 VA	2.2-3.9 VA	3.4-5.8 VA	3.4-5.8 VA	3.4-5.8 VA	6.8-12.0 VA	3.8-10.0 VA
– DC 12V	–	0.88 VA	1.6 W	1.6 W	1.6 W	2.6 W	3.4 W
– DC 24V	–	0.70 VA	3.1 W	3.1 W	3.1 W	3.6 W	4.3 W
– DC 48-60V	–	1.12-1.76 VA	2.0-3.1 W	2.0-3.1 W	2.0-3.1 W	3.5-5.5 W	4.8-7.2 W
– DC 110-125V	–	0.94-1.21 VA	1.6-2.2 W	1.6-2.2 W	1.6-2.2 W	2.9-3.6 W	3.3-3.8 W
– DC 220-250V	–	1.45-1.86 VA	3.1-4 W	3.1-4 W	3.1-4 W	4.8-6.3 W	6.6-7.5 W
Maximum Opening Time	50 ms	50 ms	50 ms	50 ms	50 ms	80 ms	80 ms
<b>Shunt Trips</b>							
Shunt Trips ("f" Releases)							
Response Voltage:							
– Pickup (Breaker Tripped) $U_s$	70-110%	70-110%	0-110%	70-110%	70-110%	70-110%	70-110%
Power Consumption in (Short Time) at:							
– AC 50/60 Hz 12-24V	–	10-41 VA	87-405 VA	87-405 VA	81-701 VA	86-631 VA	177-1207 VA
– AC 50/60 Hz 48-60V	–	139-210 VA	710-1105 VA	710-1105 VA	58-90 VA	48-71 VA	443-731 VA
– AC 50/60 Hz 48-127V	–	–	–	–	–	–	–
– AC 50/60 Hz 110-240V	135-500 VA	83-360 VA	66-432 VA	66-432 VA	118-665 VA	81-505 VA	323-1466 VA
– AC 50/60 Hz 380-440V	–	–	127-188 VA	127-188 VA	125-181 VA	43-68 VA	1193-1641 VA
– AC 50/60 Hz 380-600V	–	418-1080 VA	–	–	–	–	–
– AC 50/60 Hz 480-600V	–	–	34-60 VA	34-60 VA	43-79 VA	41-69 VA	197-312 VA
– DC 12-24V	–	29-120 W	164-631 W	164-631 W	79-1000 W	46-405 W	289-865 W
– DC 48-60V	–	475-720 W	830-1580 W	830-1580 W	18-31 W	58-94 W	468-696 W
– DC 110-125V	–	99-121 W	112-150 W	112-150 W	112-150 W	74-98 W	363-473 W
– DC 220-250V	–	–	40-58 W	40-58 W	38-52 W	38-49 W	513-665 W
Maximum Load Duration	Interrupts Automatically						
Maximum Opening Time	50 ms	50 ms	50 ms	50 ms	50 ms	62 ms	62 ms



## Electrical Characteristics

### DC Switching Duty

The E- to L-Frame circuit breakers are also suitable for switching dc currents.

The N- and R-Frame circuit breakers, FWMP, KWMP, and LWMP circuit breakers for motor protection are not suitable for dc currents due to the solid state overcurrent release system.

For switching dc currents, however, the maximum permissible dc voltage per conducting path has to be considered.

For voltages higher than 250 volts, the series connection of two or three conducting paths is required.

As the current has to flow through all conducting paths so as to maintain the thermal tripping characteristics, the following circuit arrangements are recommended. With dc, the trip values of the instantaneous short circuit release ("n" release) are increased by 30 to 40%.

### For 3- and 4-Pole Circuit Breakers

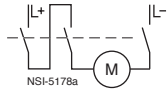
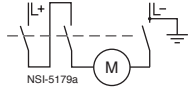
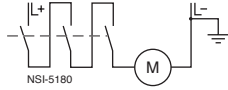
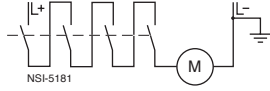
Proposed Circuit	Maximum Permissible VDC $U_e$	Remarks
	250 VDC	Double-pole switching. If there is no risk of an earth fault, or if any earth fault which occurs is immediately eliminated (earth fault monitoring), the maximum permissible dc voltage can be 600 volts.
	440 VDC	Double-pole switching (earth system). The earthed pole must always be assigned to the individual conducting path, so that two paths are always in series in the event of an earth fault.
	600 VDC	Single-pole switching (earthed system). Three conducting paths in series. The earthed pole must be assigned to the nonswitched conducting path.
	750 VDC	Single-pole switching (earthed system). Four conducting paths in series. The earthed pole must be assigned to the nonswitched conducting path.

Cutler-Hammer Frame Sizes K through R

## Multi-Function Electronic Trip Units for All Applications

### Digitrip™ RMS Trip Units

#### True rms Sensing

Digitrip RMS Trip Units utilize our proprietary SURE™ Chip and SuRE Plus™ Chip microprocessor-based intelligence to provide true rms sensing, permitting increased accuracy and reliable system protection. True rms sensing is not susceptible to nuisance tripping when waveforms containing high harmonic currents are present.

#### Digitrip RMS 310

Digitrip RMS 310 Electronic Trip Units are available with Cutler-Hammer Circuit Breakers K-, L-, N- and R-Frames 63 through 2500 amperes. Digitrip RMS 310 Trip Units are available in four styles with either fixed or adjustable rating plugs which establishes the continuous ampere rating of the breaker.

#### Rating Plugs

Digitrip RMS 310 Trip Units incorporate rating plugs that are interchangeable within a specific circuit breaker frame. This provides the user with versatility when establishing the continuous current rating of a breaker. Rating plugs are frequency sensitive and may be specified for 50 / 60 Hz applications. Both fixed and adjustable rating plugs are available, providing further flexibility when applied to selectively coordinated systems.

Note: *Digitrip RMS rating plugs are not interchangeable with SELTRONIC™ rating plugs.*

#### Curve Shaping

When selectively coordinated systems are called for, Digitrip RMS 310 will provide a cost-effective solution for a variety of applications.

The standard Digitrip RMS 310 includes an adjustable short time pickup setting encompassing an  $I^2t$  ramp function which provides the basic LS curve shaping function.

The optional Digitrip RMS 310 provides additional flat response short time delay adjustments on an instantaneous setting to provide LSI curve shaping capability.

Both Digitrip RMS 310 Trip Units are available with ground fault pickup and flat response ground fault delay which provide the trip unit with full function LSG and LSIG curve shaping flexibility.

Digitrip RMS 310 Trip Units can effectively coordinate with both sophisticated upstream power breakers as well as downstream thermal magnetic breakers...making Digitrip RMS 310 Trip Units the cost-effective reliable choice for selectively coordinated systems.

#### Thermal Memory

All Digitrip RMS Trip Units incorporate a long delay and, when ordered with ground, a ground fault thermal memory feature. Thermal memory prevents the system from cumulative overheating due to repeated overcurrent events that may occur in quick succession.

### Digitrip RMS 610 and 910

Digitrip RMS 610, and 910 Trip Units are available with Cutler-Hammer R-Frame Circuit Breakers 800 through 2500 amperes. Digitrip 610 and 910 Trip Units provide unparallelled system protection with fixed rating plugs to establish the continuous ampere rating of the breaker.

#### Curve Shaping

Digitrip RMS 610 and 910 Trip Units are available with up to nine curve shaping choices achieved by adjusting up to seven switches on the front of the unit for optimum system coordination. Maximum curve shaping flexibility is provided by dependent long and short delay adjustments that are long delay pickup ( $I_r$ ) based, depicted on the front of the unit by the blue portion of the time-current curve.

Additional coordination capability can be provided by utilizing the short delay and ground fault zone selective interlocking features available on these trip units.

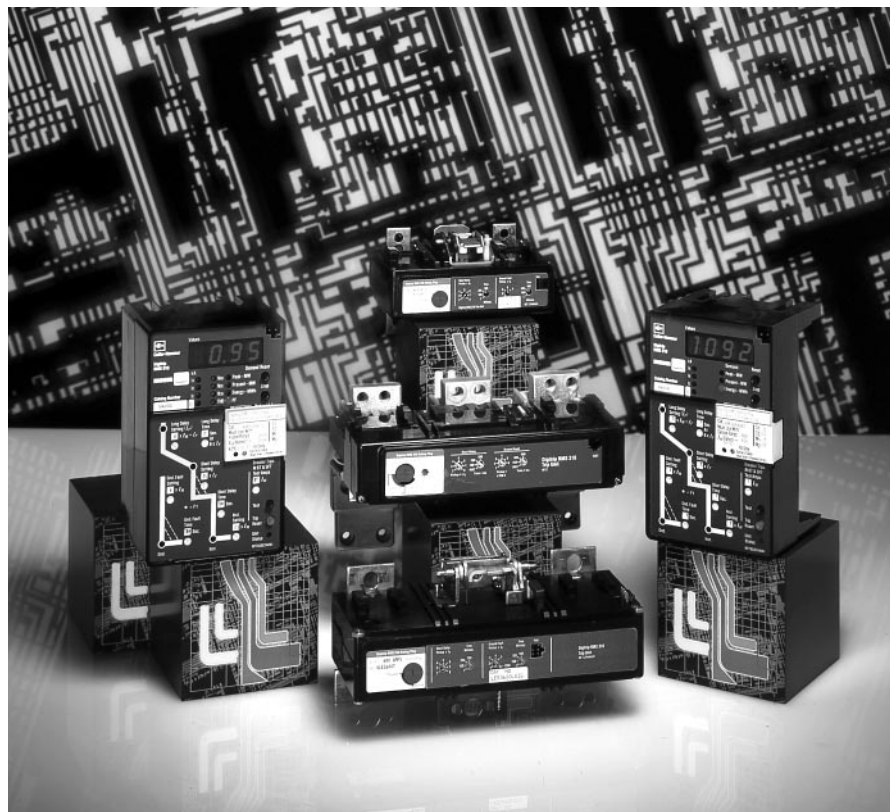

R-Frame Digitrip RMS 310, 610 and 910 Trip Units (Noninterchangeable)

### Cutler-Hammer Frame Size R

#### System Diagnostics

All four Digitrip RMS models of trip units provide long delay, short delay, instantaneous, and ground fault cause of trip LEDs on the front of the unit. Digitrip RMS 610 and 910 also offer a magnitude of trip information as well as remote signal contacts for improved system diagnostics.

#### System Monitoring

Digitrip 610 and 910 Trip Units have the capability to monitor phase currents as well as neutral or ground currents. This information is displayed on a large digital display mounted on the unit.

Digitrip RMS 910 Trip Units can also provide the user with power and energy monitoring capability. Peak power demand, present power

demand, and total energy as well as forward and reverse energy can be monitored with this unit.

Digitrip RMS 910 Trip Units have the additional capability of monitoring line to line voltage as well as system power factor. Both parameters are displayed in the digital display window and are supported by LEDs to indicate which parameter is being displayed.

#### Harmonics Monitoring

Digitrip RMS 910 Trip Units are capable of displaying values of current harmonics in the digital display window. Percentage of harmonic content can be monitored for each phase, neutral or ground, up to the 27th harmonic. Additionally, a total harmonic distortion value can be calculated and displayed.

#### Communications







Digitrip RMS 810 and 910 have built-in communications options to allow all protection, monitoring, and control information to be transmitted back to a central location via the Cutler-Hammer PowerNet System.

#### Field Testing

Integral field testing capability is provided on all 610 and 910 Trip Units. No additional test set is needed to perform both trip and no trip field testing.

## Cutler-Hammer Frame Sizes K through R

## Digitrip RMS Electronic Trip Unit Selection Guide

Digitrip	RMS 310	RMS 610	RMS 910
	   		

### Breaker Type

Cutler-Hammer Frame(s)	K-, L-, N- and R-Frames	R-Frame	R-Frame
Ampere Rating	70A-2500A	800A-2500A	800A-2500A
Interrupting Rating at 415V	35, 70, 100 kA	70, 100 kA	70, 100 kA

### Trip Unit Sensing

rms Sensing	Yes	Yes	Yes
-------------	-----	-----	-----

### Protection and Coordination

Protection	Ordering Options	LS, LSG	LSI, LSIG	LI, LSI, LIG, LSG, LSIG	LI, LS, LSI, LIG, LSG, LSIG
	Fixed Rating Plug ( $I_n$ )	Yes	Yes	Yes	Yes
	Overtemperature Trip	Yes	Yes	Yes	Yes
Long Delay	Adjustable Rating Plug (In)	Yes	Yes	No	No
	Long Delay Setting	0.5-1.0 ( $I_n$ ) <sup>①</sup>	0.5-1.0 ( $I_n$ ) <sup>①</sup>	0.5-1.0 ( $I_n$ )	0.5-1.0 ( $I_n$ )
	Long Delay Time $I^2t$	12 Seconds	12 Seconds	2-24 Seconds	2-24 Seconds
	Long Delay Thermal Memory	Yes	Yes	Yes	Yes
	High Load Alarm	No	No	0.85 x $I_r$	0.85 x $I_r$
Short Delay	Short Delay Setting	200-800% x ( $I_n$ ) <sup>⑤</sup>	200-800% x ( $I_n$ ) <sup>⑤</sup>	200-600% S1 & S2 x ( $I_r$ )	200-600% S1 & S2 x ( $I_r$ )
	Short Delay Time $I^2t$	100 ms	No	100-500 ms	100-500 ms
	Short Delay Time Flat	No	1-300 ms	100-500 ms	100-500 ms
	Short Delay Time ZSI	No	No	Yes	Yes
Instantaneous	Instantaneous Setting	No	200-800% x ( $I_n$ )	200-600% M1 & M2 x ( $I_n$ )	200-600% M1 & M2 x ( $I_n$ )
	Discriminator	No	No	Yes <sup>④</sup>	Yes <sup>④</sup>
	Instantaneous Override	Yes	Yes	Yes	Yes
Ground Fault	Ground Fault Setting	Var/Frame <sup>③</sup>	Var/Frame <sup>③</sup>	25-100% x ( $I_n$ ) <sup>③</sup>	25-100% x ( $I_n$ ) <sup>③</sup>
	Fault Delay $I^2t$	No	No	100-500 ms	100-500 ms
	Ground Fault Delay Flat	1-500 ms	1-500 ms	1-500 ms	1-500 ms
	Ground Fault ZSI	No	No	Yes	Yes
	Ground Fault Thermal Memory	Yes	Yes	Yes	Yes

### System Diagnostics

Cause of Trip LEDs	No	No	Yes	Yes
Magnitude of Trip Information	No	No	Yes	Yes
Remote Signal Contacts	No	No	Yes	Yes

### System Monitoring

Digital Display	No	No	Yes	Yes
Current	No	No	Yes	Yes
Voltage	No	No	No	Yes
Power and Energy	No <sup>②</sup>	No <sup>②</sup>	No	Yes
Power Quality - Harmonics	No	No	No	Yes
Power Factor	No	No	No	Yes

### System Communications

PowerNet	No	No	No	Yes
----------	----	----	----	-----

### Field Testing

Testing Method <sup>①</sup>	Test Set	Test Set	Integral	Integral
-----------------------------	----------	----------	----------	----------

① Set by adjustable rating plug  
 ② Yes, with addition of Energy Sentinal.  
 ③ Not to exceed 1200A.

④ LS, LSG only.  
 ⑤ 2500A R-frame 200-600% x ( $I_n$ )

$I_n$  = Rating plug rating.  
 $I_r$  = LDPU setting.

### Selection Guide and Ordering Information

Maximum Continuous Ampere Rating at 40°C <sup>①</sup>	Standard Interrupting Capacity Catalogue Number		
	U <sub>e</sub> Maximum 240 VAC		U <sub>e</sub> Maximum 440 VAC
	20 kA I <sub>cu</sub> at 240 VAC		25 kA I <sub>cu</sub> at 415 VAC
	Type GWF <sup>②</sup>		
	1-Pole	2-Pole	3-Pole

**Fixed Thermal/Fixed Magnetic Circuit Breakers**  
Sealed Breakers with Noninterchangeable Trip Units and Line and Load Terminals

16	GWF1016	GWF2016	GWF3016
20	GWF1020	GWF2020	GWF3020
25	GWF1025	GWF2025	GWF3025
32	GWF1032	GWF2032	GWF3032
40	GWF1040	GWF2040	GWF3040
50	GWF1050	GWF2050	GWF3050
63	GWF1063	GWF2063	GWF3063
80	GWF1080	GWF2080	GWF3080
100	GWF1100	GWF2100	GWF3100

**Terminals (Factory Fitted Only)**

Frame	Amperes	Terminal Type	Wire Type	Wire Range
G	16-100	Pressure Type	Copper	2.5-50

<sup>①</sup> Special 50°C rating available. Order by description.

<sup>②</sup> GWF is direct supersedure for GW fixed thermal magnetic breaker.

**Cutler-Hammer Frame Size E, 15-125 Amperes**

**Selection Guide and Ordering Information**

Maximum Continuous Ampere Rating at 40°C <sup>①</sup>	IC Rating @ 415/480 V							
	1-Pole		2-Pole <sup>②</sup>		3-Pole		4-Pole	
	Fixed Thermal Fixed Magnetic	Fixed Thermal Fixed Magnetic	Fixed Thermal Fixed Magnetic	Adjustable Thermal <sup>①</sup> Fixed Magnetic	Thermal Range	Fixed Thermal Fixed Magnetic	Adjustable Thermal <sup>①</sup> Fixed Magnetic	Thermal Range

**Complete Circuit Breaker**  
**Includes Frame, Trip Unit, Standard Terminals, and Mounting Hardware**

IEC/CE/UL/CSA 18/18								
15	EGB1015FFG	EGB2015FFG	EGB3015FFG	-	-	EGB4015FFG	-	-
16	EGB1016FFG	EGB2016FFG	EGB3016FFG	-	-	EGB4016FFG	-	-
20	EGB1020FFG	EGB2020FFG	EGB3020FFG	EGB3020AFG	16-20	EGB4020FFG	EGB4020AFG	16-20
25	EGB1025FFG	EGB2025FFG	EGB3025FFG	EGB3025AFG	20-25	EGB4025FFG	EGB4025AFG	20-25
30	EGB1030FFG	EGB2030FFG	EGB3030FFG	-	-	EGB4030FFG	-	-
32	EGB1032FFG	EGB2032FFG	EGB3032FFG	EGB3032AFG	25-32	EGB4032FFG	EGB4032AFG	25-32
35	EGB1035FFG	EGB2035FFG	EGB3035FFG	-	-	EGB4035FFG	-	-
40	EGB1040FFG	EGB2040FFG	EGB3040FFG	EGB3040AFG	32-40	EGB4040FFG	EGB4040AFG	32-40
45	EGB1045FFG	EGB2045FFG	EGB3045FFG	-	-	EGB4045FFG	-	-
50	EGB1050FFG	EGB2050FFG	EGB3050FFG	EGB3050AFG	40-50	EGB4050FFG	-	-
60	EGB1060FFG	EGB2060FFG	EGB3060FFG	-	-	EGB4060FFG	-	-
63	EGB1063FFG	EGB2063FFG	EGB3063FFG	EGB3063AFG	50-63	EGB4063FFG	EGB4063AFG	50-63
70	EGB1070FFG	EGB2070FFG	EGB3070FFG	-	-	EGB4070FFG	-	-
80	EGB1080FFG	EGB2080FFG	EGB3080FFG	EGB3080AFG	63-80	EGB4080FFG	EGB4080AFG	63-80
90	EGB1090FFG	EGB2090FFG	EGB3090FFG	-	-	EGB4090FFG	-	-
100	EGB1100FFG	EGB2100FFG	EGB3100FFG	EGB3100AFG	80-100	EGB4100FFG	EGB4100AFG	80-100
125	EGB1125FFG	EGB2125FFG	EGB3125FFG	-	-	EGB4125FFG	EGB4125AFG	100-125
125	-	-	EGB3125KSG	EGB3125AFG	100-125	EGB4125KSG	-	-

IEC/CE/UL/CSA 25/25								
15	-	EGE2015FFG	EGE3015FFG	-	-	EGE4015FFG	-	-
16	-	EGE2016FFG	EGE3016FFG	-	-	EGE4016FFG	-	-
20	-	EGE2020FFG	EGE3020FFG	EGE3020AFG	16-20	EGE4020FFG	EGE4020AFG	16-20
25	-	EGE2025FFG	EGE3025FFG	EGE3025AFG	20-25	EGE4025FFG	EGE4025AFG	20-25
30	-	EGE2030FFG	EGE3030FFG	-	-	EGE4030FFG	-	-
32	-	EGE2032FFG	EGE3032FFG	EGE3032AFG	25-32	EGE4032FFG	EGE4032AFG	25-32
35	-	EGE2035FFG	EGE3035FFG	-	-	EGE4035FFG	-	-
40	-	EGE2040FFG	EGE3040FFG	EGE3040AFG	32-40	EGE4040FFG	EGE4040AFG	32-40
45	-	EGE2045FFG	EGE3045FFG	-	-	EGE4045FFG	-	-
50	-	EGE2050FFG	EGE3050FFG	EGE3050AFG	40-50	EGE4050FFG	-	-
60	-	EGE2060FFG	EGE3060FFG	-	-	EGE4060FFG	-	-
63	-	EGE2063FFG	EGE3063FFG	EGE3063AFG	50-63	EGE4063FFG	EGE4063AFG	50-63
70	-	EGE2070FFG	EGE3070FFG	-	-	EGE4070FFG	-	-
80	-	EGE2080FFG	EGE3080FFG	EGE3080AFG	63-80	EGE4080FFG	EGE4080AFG	63-80
90	-	EGE2090FFG	EGE3090FFG	-	-	EGE4090FFG	-	-
100	-	EGE2100FFG	EGE3100FFG	EGE3100AFG	80-100	EGE4100FFG	EGE4100AFG	80-100
125	-	EGE2125FFG	EGE3125FFG	EGE3125AFG	100-125	EGE4125FFG	EGE4125AFG	100-125
125	-	-	EGE3125KSG	-	-	EGE4125KSG	-	-

IEC/CE/UL/CSA 40/35								
15	EGS1015FFG	EGS2015FFG	EGS3015FFG	-	-	EGS4015FFL	-	-
16	EGS1016FFG	EGS2016FFG	EGS3016FFG	-	-	EGS4016FFL	-	-
20	EGS1020FFG	EGS2020FFG	EGS3020FFG	EGS3020AFG	16-20	EGS4020FFL	EGS4020AFG	16-20
25	EGS1025FFG	EGS2025FFG	EGS3025FFG	EGS3025AFG	20-25	EGS4025FFL	EGS4025AFG	20-25
30	EGS1030FFG	EGS2030FFG	EGS3030FFG	-	-	EGS4030FFL	-	-
32	EGS1032FFG	EGS2032FFG	EGS3032FFG	EGS3032AFG	25-32	EGS4032FFL	EGS4032AFG	25-32
35	EGS1035FFG	EGS2035FFG	EGS3035FFG	-	-	EGS4035FFL	-	-
40	EGS1040FFG	EGS2040FFG	EGS3040FFG	EGS3040AFG	32-40	EGS4040FFL	EGS4040AFG	32-40
45	EGS1045FFG	EGS2045FFG	EGS3045FFG	-	-	EGS4045FFL	-	-
50	EGS1050FFG	EGS2050FFG	EGS3050FFG	EGS3050AFG	40-50	EGS4050FFL	-	-
60	EGS1060FFG	EGS2060FFG	EGS3060FFG	-	-	EGS4060FFL	-	-
63	EGS1063FFG	EGS2063FFG	EGS3063FFG	EGS3063AFG	50-63	EGS4063FFL	EGS4063AFG	50-63
70	EGS1070FFG	EGS2070FFG	EGS3070FFG	-	-	EGS4070FFL	-	-
80	EGS1080FFG	EGS2080FFG	EGS3080FFG	EGS3080AFG	63-80	EGS4080FFL	EGS4080AFG	63-80
90	EGS1090FFG	EGS2090FFG	EGS3090FFG	-	-	EGS4090FFL	-	-
100	EGS1100FFG	EGS2100FFG	EGS3100FFG	EGS3100AFG	80-100	EGS4100FFL	EGS4100AFG	80-100
125	EGS1125FFG	EGS2125FFG	EGS3125FFG	EGS3125AFG	100-125	EGS4125FFL	EGS4125AFG	100-125
125	-	-	EGS3125KSG	-	-	EGS4125KSL	-	-

IEC/CE/UL/CSA 70/65								
15	EGH1015FFG	EGH2015FFG	EGH3015FFG	-	-	EGH4015FFG	-	-
16	EGH1016FFG	EGH2016FFG	EGH3016FFG	-	-	EGH4016FFG	-	-
20	EGH1020FFG	EGH2020FFG	EGH3020FFG	EGH3020AFG	16-20	EGH4020FFG	EGH4020AFG	16-20
25	EGH1025FFG	EGH2025FFG	EGH3025FFG	EGH3025AFG	20-25	EGH4025FFG	EGH4025AFG	20-25
30	EGH1030FFG	EGH2030FFG	EGH3030FFG	-	-	EGH4030FFG	-	-
32	EGH1032FFG	EGH2032FFG	EGH3032FFG	EGH3032AFG	25-32	EGH4032FFG	EGH4032AFG	25-32
35	EGH1035FFG	EGH2035FFG	EGH3035FFG	-	-	EGH4035FFG	-	-
40	EGH1040FFG	EGH2040FFG	EGH3040FFG	EGH3040AFG	32-40	EGH4040FFG	EGH4040AFG	32-40
45	EGH1045FFG	EGH2045FFG	EGH3045FFG	-	-	EGH4045FFG	-	-
50	EGH1050FFG	EGH2050FFG	EGH3050FFG	EGH3050AFG	40-50	EGH4050FFG	EGH4050AFG	40-50
60	EGH1060FFG	EGH2060FFG	EGH3060FFG	-	-	EGH4060FFG	-	-
63	EGH1063FFG	EGH2063FFG	EGH3063FFG	EGH3063AFG	50-63	EGH4063FFG	EGH4063AFG	50-63
70	EGH1070FFG	EGH2070FFG	EGH3070FFG	-	-	EGH4070FFG	-	-
80	EGH1080FFG	EGH2080FFG	EGH3080FFG	EGH3080AFG	63-80	EGH4080FFG	EGH4080AFG	63-80
90	EGH1090FFG	EGH2090FFG	EGH3090FFG	-	-	EGH4090FFG	-	-
100	EGH1100FFG	EGH2100FFG	EGH3100FFG	EGH3100AFG	80-100	EGH4100FFG	EGH4100AFG	80-100
125	EGH1125FFG	EGH2125FFG	EGH3125FFG	EGH3125AFG	100-125	EGH4125FFG	EGH4125AFG	100-125
125	-	-	EGH3125KSG	-	-	EGH4125KSG	-	-

① 16, 32, 63 A are not UL Listed ratings and adjustable thermal not UL listed.

② Two-pole E-Frame breakers available June 2001.



### Selection Guide and Ordering Information

#### Line and Load Terminals

E-Frame circuit breakers and moulded case switches have line and load terminals as standard equipment.

Maximum Breaker Amperes	Terminal Body Material	Wire Type	Metric Wire Range mm <sup>2</sup>	AWG Wire Range	Catalogue Number Package of 3 Terminals
<b>Standard Cu/Al Pressure Type Terminals</b>					
125	Steel	Cu	2.5-95	#14-3/0	3T125EF①
125	Aluminium	Cu/Al	2.5-50	#14-1/0	3TA125EF
125	Aluminium	Cu/Al	16-70	#6-3/0	3TA150EF

#### Catalogue Number

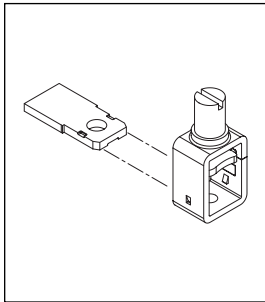

3T125EF①

Insert collar enclosing conductor as shown. Locate nut on top of conductor and tighten securely with screw and washer. Caution: Collar must surround conductor.

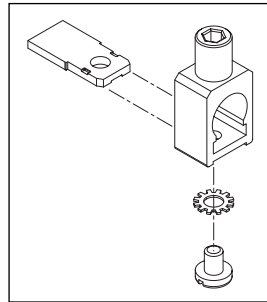

3TA125EF

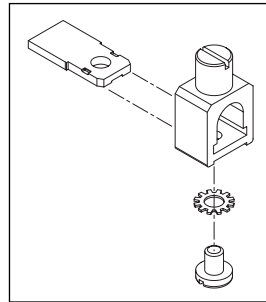

3TA150EF

Insert collar enclosing conductor and centre on extrusion. Tighten securely with screw and washer.

#### Endcap Kit

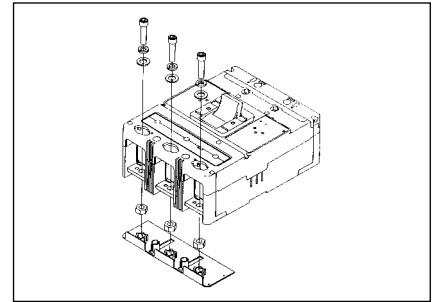

EF3RTWK 3-Pole – Metric,  
EF4RTWK 4-Pole – Metric,  
EF3RTDK 3-Pole – Imperial,  
EF4RTDK 4-Pole – Imperial

Endcap kits are used on E-frame breaker line load to connect bus bar or similar electrical connections. Includes hardware.

#### Control Wire Terminal Kit

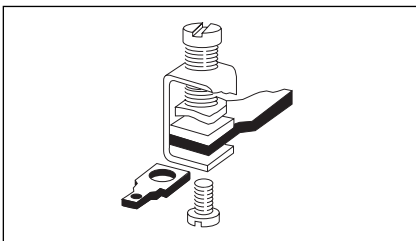

For use with steel or stainless steel① terminals only.

Package of 12 – Priced Individually
Catalogue Number – EFCWTK

#### Interphase Barriers

The interphase barrier is available for extended insulation between circuit breaker poles. Specify quantity when ordering.

Package of 2
Catalogue Number – EFIPBK

#### Base Mounting Hardware

Base mounting hardware is included with a circuit breaker or moulded case switch. (Included with breaker).

DIN Rail Adapter	Catalogue Number
3- or 4-Pole	EF34DIN

#### Terminal Shields

The terminal shield is available for line terminal areas in 2-, 3-, and 4-pole circuit breakers. Special terminal shields are also available for use when an electrical (solenoid) operator is mounted on the circuit breaker. The standard style number by pole for each terminal shield is for a package of 10 and is priced per each package. Special terminal shields are packaged individually.

Number of Poles	Standard Package of 10	IP30 Protection
	Catalogue Numbers – Priced Individually	
2	EFTS2K	
3	EFTS3K	
4	EFTS4K	

#### Terminal End Covers

The terminal end cover is available for 3-pole circuit breakers only. Two conductor opening sizes are available. Specify quantity (one per circuit breaker) when ordering.

Conductor Opening Diameter – mm (Inches)	Catalogue Number
6.35 (0.25)	EFTC3K
10.41 (0.41)	EFTC4K

① Standard line and load terminals.



## Cutler-Hammer Frame Size J, 100-250 Amperes

### Selection Guide and Ordering Information

Maximum Continuous Ampere Rating at 40°C	Magnetic Range	IC Rating @ 415/480 V						
		2-Pole		3-Pole			4-Pole <sup>①</sup>	
		Fixed Thermal Adjustable Magnetic	Fixed Thermal Adjustable Magnetic	Adjustable Thermal Adjustable Magnetic <sup>②</sup>	Thermal Range	Fixed Thermal Adjustable Magnetic	Adjustable Thermal Adjustable Magnetic <sup>②</sup>	Thermal Range
<b>Complete Circuit Breaker</b>								
<b>Includes Frame, Trip Unit, Standard Terminals, and Mounting Hardware</b>								
<b>IEC/CE/UL/CSA 25/25</b>								
63	315-630	—	JGE3063FAG <sup>②</sup>	JGE3063AAG	40-63	JGE4063FAG <sup>②</sup>	JGE4063AAG	40-63
70	350-700	JGE2070FAG	JGE3070FAG	—	—	JGE4070FAG	—	—
90	450-900	JGE2090FAG	JGE3090FAG	—	—	JGE4090FAG	—	—
100	500-1000	JGE2100FAG	JGE3100FAG	JGE3100AAG	63-100	JGE4100FAG	JGE4100AAG	63-100
125	625-1250	JGE2125FAG	JGE3125FAG	JGE3125AAG	100-125	JGE4125FAG	JGE4125AAG	100-125
150	750-1500	JGE2150FAG	JGE3150FAG	—	—	JGE4150FAG	—	—
160	800-1600	—	JGE3160FAG <sup>②</sup>	JGE3160AAG	125-160	JGE4160FAG <sup>②</sup>	JGE4160AAG	125-160
175	875-1750	JGE2175FAG	JGE3175FAG	—	—	JGE4175FAG	—	—
200	1000-2000	JGE2200FAG	JGE3200FAG	JGE3200AAG	160-200	JGE4200FAG	JGE4200AAG	160-200
225	1125-2250	JGE2225FAG	JGE3225FAG	—	—	JGE4225FAG	—	—
250	1250-2500	JGE2250FAG	JGE3250FAG	JGE3250AAG	200-250	JGE4250FAG	JGE4250AAG	200-250
250	1250-2500	③	JGE3250KSG	—	—	JGE4250KSG	—	—

<b>IEC/CE/UL/CSA 40/35</b>								
63	315-630	—	JGS3063FAG <sup>②</sup>	JGS3063AAG	40-63	JGS4063FAG <sup>②</sup>	JGS4063AAG	40-63
70	350-700	JGS2070FAG	JGS3070FAG	—	—	JGS4070FAG	—	—
90	450-900	JGS2090FAG	JGS3090FAG	—	—	JGS4090FAG	—	—
100	500-1000	JGS2100FAG	JGS3100FAG	JGS3100AAG	63-100	JGS4100FAG	JGS4100AAG	63-100
125	625-1250	JGS2125FAG	JGS3125FAG	JGS3125AAG	100-125	JGS4125FAG	JGS4125AAG	100-125
150	750-1500	JGS2150FAG	JGS3150FAG	—	—	JGS4150FAG	—	—
160	800-1600	—	JGS3160FAG <sup>②</sup>	JGS3160AAG	125-160	JGS4160FAG <sup>②</sup>	JGS4160AAG	125-160
175	875-1750	JGS2175FAG	JGS3175FAG	—	—	JGS4175FAG	—	—
200	1000-2000	JGS2200FAG	JGS3200FAG	JGS3200AAG	160-200	JGS4200FAG	JGS4200AAG	160-200
225	1125-2250	JGS2225FAG	JGS3225FAG	—	—	JGS4225FAG	—	—
250	1250-2500	JGS2250FAG	JGS3250FAG	JGS3250AAG	200-250	JGS4250FAG	JGS4250AAG	200-250
250	1250-2500	③	JGS3250KSG	—	—	JGS4250KSG	—	—

<b>IEC/CE/UL/CSA 70/65</b>								
63	315-630	—	JGH3063FAG <sup>②</sup>	JGH3063AAG	40-63	JGH4063FAG <sup>②</sup>	JGH4063AAG	40-63
70	350-700	JGH2070FAG	JGH3070FAG	—	—	JGH4070FAG	—	—
90	450-900	JGH2090FAG	JGH3090FAG	—	—	JGH4090FAG	—	—
100	500-1000	JGH2100FAG	JGH3100FAG	JGH3100AAG	63-100	JGH4100FAG	JGH4100AAG	63-100
125	625-1250	JGH2125FAG	JGH3125FAG	JGH3125AAG	100-125	JGH4125FAG	JGH4125AAG	100-125
150	750-1500	JGH2150FAG	JGH3150FAG	—	—	JGH4150FAG	—	—
160	800-1600	—	JGH3160FAG <sup>②</sup>	JGH3160AAG	125-160	JGH4160FAG <sup>②</sup>	JGH4160AAG	125-160
175	875-1750	JGH2175FAG	JGH3175FAG	—	—	JGH4175FAG	—	—
200	1000-2000	JGH2200FAG	JGH3200FAG	JGH3200AAG	160-200	JGH4200FAG	JGH4200AAG	160-200
225	1125-2250	JGH2225FAG	JGH3225FAG	—	—	JGH4225FAG	—	—
250	1250-2500	JGH2250FAG	JGH3250FAG	JGH3250AAG	200-250	JGH4250FAG	JGH4250AAG	200-250
250	1250-2500	③	JGH3250KSG	—	—	JGH4250KSG	—	—

#### Components Frame

<b>IEC/CE/UL/CSA 25/25</b>								
250	—	JGE2250NN	JGE3250NN	—	—	JGE4250NN	—	—
<b>IEC/CE/UL/CSA 40/35</b>								
250	—	JGS2250NN	JGS3250NN	—	—	JGS4250NN	—	—
<b>IEC/CE/UL/CSA 70/65</b>								
250	—	JGH2250NN	JGH3250NN	—	—	JGH4250NN	—	—

#### Trip Unit

63	315-630	JT2063FA <sup>②</sup>	JT3063FA <sup>②</sup>	JT3063AA <sup>②</sup>	40-63	JT4063FA <sup>②</sup>	JT4063AA <sup>②</sup>	40-63
70	350-700	JT2070FA	JT3070FA	—	—	JT4070FA	—	—
90	450-900	JT2090FA	JT3090FA	—	—	JT4090FA	—	—
100	500-1000	JT2100FA	JT3100FA	JT3100AA <sup>②</sup>	63-100	JT4100FA	JT4100AA <sup>②</sup>	63-100
125	625-1250	JT2125FA	JT3125FA	JT3125AA <sup>②</sup>	100-125	JT4125FA	JT4125AA <sup>②</sup>	100-125
150	750-1500	JT2150FA	JT3150FA	—	—	JT4150FA	—	—
160	800-1600	JT2160FA <sup>②</sup>	JT3160FA <sup>②</sup>	JT3160AA <sup>②</sup>	125-160	JT4160FA <sup>②</sup>	JT4160AA <sup>②</sup>	125-160
175	875-1750	JT2175FA	JT3175FA	—	—	JT4175FA	—	—
200	1000-2000	JT2200FA	JT3200FA	JT3200AA <sup>②</sup>	160-200	JT4200FA	JT4200AA <sup>②</sup>	160-200
225	1125-2250	JT2225FA	JT3225FA	—	—	JT4225FA	—	—
250	1250-2500	JT2250FA	JT3250FA	JT3250AA <sup>②</sup>	200-250	JT4250FA	JT4250AA <sup>②</sup>	200-250

① Change the 4th digit to 8 for adjustable 0-60% neutral protection, 9 for 0-100% neutral protection.

② IEC-EN 60947-2 only.

③ Use 3-pole MCS.

**Selection Guide and Ordering Information**

**Line and Load Terminals**

J250-Frame circuit breakers include Cu terminals, T250FJ as standard. When optional copper or Cu/Al terminals are required, order by catalogue number.

Maximum Breaker Amperes	Terminal Body Material	Wire Type	Metric Wire Range mm <sup>2</sup>	AWG Wire Range/ Number Conductors	Catalogue Number
<b>Standard Pressure Type Terminals</b>					
250	Stainless Steel	Cu	25-185	4-350/(1)	T250FJ①②
250	Aluminium	Cu/Al	25-185	4-350/(1)	TA250FJ①
<b>Optional Copper and Cu/Al Pressure Type Terminals</b>					
250	Copper	Cu/Al	25-185	4-350/(1)	TC250FJ①

**Catalogue Number**

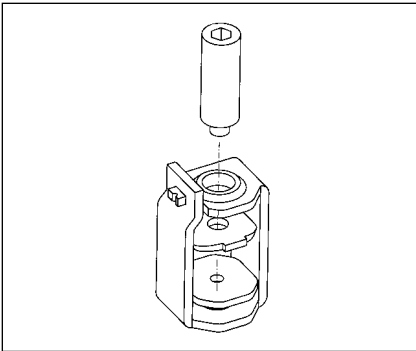

T250FJ

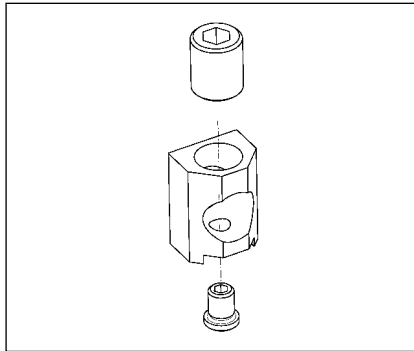

TA250FJ

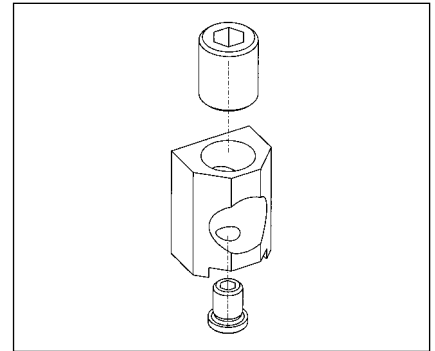

TC250FJ

**Endcap Kit**

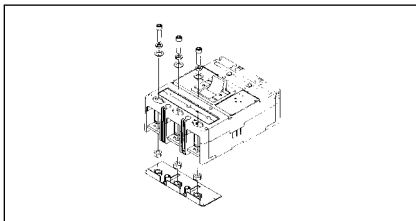

Endcap kits are used on J250 Frame breaker line load to connect bus bar or similar electrical connections. Includes hardware.

**Kit Catalogue Number**

Number of Poles	Catalogue Number	
	Metric	Imperial
3	FJ3RTWK	FJ3RTDK
4	FJ4RTWK	FJ4RTDK

**Control Wire Terminal Kit**

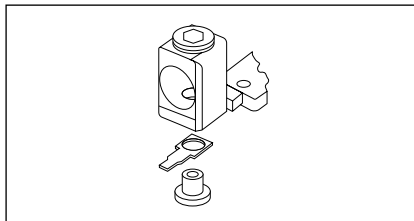

For use with aluminium or copper terminals only.

Package of 14 - Priced Individually
Catalogue Number – FJCWTK

**Base Mounting Hardware**

Base mounting hardware is included with a circuit breaker or moulded case switch. (Included with breaker).

**Terminal Shields IP30**

Location	Number of Poles	Catalogue Number Package of 10
Line or Load	2, 3 4	FJTS3K FJTS4K

**Interphase Barriers**

Package of 2	
Number of Poles	Catalogue Number
3	FJIPBK
4	FJIPBK4

① Individually packed.  
② Standard line and load terminals.

Cutler-Hammer Frame Size K, 63-400 Amperes

Selection Guide and Ordering Information

Maximum Continuous Ampere Rating at 40°C <sup>①②</sup>	Number of Poles	Thermal Range	Magnetic Range	Standard Interrupting Capacity Catalogue Number		High Interrupting Capacity Catalogue Number		Ultra-High Interrupting Capacity Catalogue Number		Thermal Magnetic Trip Unit Only	Standard Terminals Only Catalogue Number	Metric Mounting Hardware Catalogue Number
				U <sub>e</sub> Max. 690 VAC		U <sub>e</sub> Max. 690 VAC		U <sub>e</sub> Max. 690 VAC				
				45 kA I <sub>cu</sub> at 415 VAC		70 kA I <sub>cu</sub> at 415 VAC		100 kA I <sub>cu</sub> at 415 VAC				
				Factory Assembled Circuit Breaker Consisting of Frame, Trip Unit, and Terminals and Mounting Hardware	Frame Only	Factory Assembled Circuit Breaker Consisting of Frame, Trip Unit, and Terminals and Mounting Hardware	Frame Only	Factory Assembled Circuit Breaker Consisting of Frame, Trip Unit, and Terminals and Mounting Hardware	Frame Only	For Use with Standard or High or Ultra-High Interrupting Frame		
										Adjustable Thermal		
										Adjustable Magnetic		

Adjustable Thermal Magnetic Circuit Breakers with Interchangeable Trip Units

				Type KW		Type HKW		Type KWC				
200 250 315 400	2-Pole	160-200 200-250 250-315 315-400	1000-2000 1250-2500 1575-3150 2000-4000	KW2200 KW2250 KW2315 KW2400	KW2400F	HKW2200 HKW2250 HKW2315 HKW2400	HKW240F	KWC2200 KWC2250 KWC2315 KWC2400	KWC2400F	KT2200TA KT2250TA KT2315TA KT2400TA	TA300KM <sup>①</sup> TA300KM <sup>①</sup> TA350KM <sup>①</sup> TA350KM <sup>①</sup>	BMH3M BMH3M BMH3M BMH3M
200 250 315 400	3-Pole	160-200 200-250 250-315 315-400	1000-2000 1250-2500 1575-3150 2000-4000	KW3200 KW3250 KW3315 KW3400	KW3400F	HKW3200 HKW3250 HKW3315 HKW3400	HKW3400F	KWC3200 KWC3250 KWC3315 KWC3400	KWC3400F	KT3200TA KT3250TA KT3315TA KT3400TA	TA300KM <sup>①</sup> TA300KM <sup>①</sup> TA350KM <sup>①</sup> TA350KM <sup>①</sup>	BMH3M BMH3M BMH3M BMH3M
200 250 315 400	4-Pole	160-200 200-250 250-315 315-400	1000-2000 1250-2500 1575-3150 2000-4000	KW4200 KW4250 KW4315 KW4400 KW4315E <sup>③</sup> KW4400E <sup>③</sup>	KW4400F	HKW4200 HKW4250 HKW4315 HKW4400 HKW4315E <sup>③</sup> HKW4400E <sup>③</sup>	HKW4400F	KWC4200 KWC4250 KWC4315 KWC4400 KWC4315E <sup>③</sup> KWC4400E <sup>③</sup>	KWC4400F	KT4200TA KT4250TA KT4315TA KT4400TA KT4315TEA <sup>③</sup> KT4400TEA <sup>③</sup>	TA300KM <sup>①</sup> TA300KM <sup>①</sup> TA350KM <sup>①</sup> TA350KM <sup>①</sup>	BMH3M BMH3M BMH3M BMH3M

Adjustable Thermal Magnetic Earth Leakage Circuit Breakers with Line and Load Terminals Included

				Type ELKW (U <sub>e</sub> Max. 415 VAC)		Type ELHKW (U <sub>e</sub> Max. 415 VAC)		Type ELKWC (U <sub>e</sub> Max. 415 VAC)				
200 250 315 400	3-Pole	160-200 200-250 250-315 315-400	1000-2000 1250-2500 1575-3150 2000-4000	ELKW3200 ELKW3250 ELKW3315 ELKW3400	-	ELHKW3200 ELHKW3250 ELHKW3315 ELHKW3400	-	ELKWC3200 ELKWC3250 ELKWC3315 ELKWC3400	-	-	TA350KM TA350KM TA350KM TA350KM	BMH3M BMH3M BMH3M BMH3M
200 250 315 400	4-Pole	160-200 200-250 250-315 315-400	1000-2000 1250-2500 1575-3150 2000-4000	ELKW4200 ELKW4250 ELKW4315 ELKW4400	-	ELHKW4200 ELHKW4250 ELHKW4315 ELHKW4400	-	ELKWC4200 ELKWC4250 ELKWC4315 ELKWC4400	-	-	TA350KM TA350KM TA350KM TA350KM	BMH3M BMH3M BMH3M BMH3M

Moulded Case Switches MCS Only without Line and Load Terminals

				Type KW (U <sub>e</sub> Max. 690 VAC)		Type HKW (U <sub>e</sub> Max. 690 VAC)						
400	2-Pole 3-Pole 4-Pole	-	-	KW2400KW KW3400KW KW4400KW	-	HKW2400KW HKW3400KW HKW4400KW	-	-	-	-	TA350KM <sup>①</sup> TA350KM <sup>①</sup> TA350KM <sup>①</sup>	BMH3M BMH3M BMH3M

Electronic Circuit Breakers<sup>④</sup>

With Interchangeable Type KES Digitrip RMS Trip Units – Order as Individual Components: Breaker Frame, Trip Unit, Rating Plug, Terminals, Mounting Hardware

Maximum Continuous Ampere Rating at 40°C <sup>①②</sup>	Number of Poles	Circuit Breaker Frame Only Catalogue Number			Digitrip RMS 310 Trip Unit Only Less Rating Plug Catalogue Number				Digitrip RMS 310 Only Rating Plug Order as Individual Component			Standard Terminals Only Catalogue Number	Metric Mounting Hardware Catalogue Number
		Standard Interrupting Capacity	High Interrupting Capacity	Ultra-High Interrupting Capacity	L - Adjustable Long Delay Pickup (By Adjustable Rating Plug) S - Adjustable Short Delay Pickup with Fixed Short Delay Time (I <sup>2</sup> t Response) or Adjustable Short Delay Time (Flat Response) I - Adjustable Instantaneous Pickup by Setting Short Delay Time to Instantaneous G - Adjustable Ground Fault Pickup with Adjustable Ground Fault Delay (Flat Response)				Fixed Rating Plug		Adjustable Rating Plug		
		U <sub>e</sub> Max. 690 VAC	45 kA I <sub>cu</sub> at 415 VAC	70 kA I <sub>cu</sub> at 415 VAC	100 kA I <sub>cu</sub> at 415 VAC	LS	LSI	LSG	LSIG	Ampere Rating	Catalogue Number		
125	3-Pole	KW3400F	HKW3400F	KWC3400F	KES3125LS	KES3125LSI	KES3125LSG	KES3125LSIG	63 70 90 100 125	1KES063T 1KES070T 1KES090T 1KES100T 1KES125T	Adjustable Settings are: 63/80/100/125 A1KES125T2	TA300KM <sup>①</sup> TA300KM <sup>①</sup> TA300KM <sup>①</sup> TA300KM <sup>①</sup> TA300KM <sup>①</sup>	BMH3M BMH3M BMH3M BMH3M BMH3M
250		KW3400F	HKW3400F	KWC3400F	KES3250LS	KES3250LSI	KES3250LSG	KES3250LSIG	125 160 200 225 250	2KES125T 2KES160T 2KES200T 2KES225T 2KES250T	Adjustable Settings are: 125/160/225/250 A2KES250T2	TA300KM <sup>①</sup> TA300KM <sup>①</sup> TA300KM <sup>①</sup> TA300KM <sup>①</sup> TA300KM <sup>①</sup>	BMH3M BMH3M BMH3M BMH3M BMH3M
400		KW3400F	HKW3400F	KWC3400F	KES3400LS	KES3400LSI	KES3400LSG	KES3400LSIG	200 225 250 315 400	4KES200T 4KES225T 4KES250T 4KES315T 4KES400T	Adjustable Settings are: 200/250/315/400 A4KES400T2	TA300KM <sup>①</sup> TA300KM <sup>①</sup> TA300KM <sup>①</sup> TA350KM <sup>①</sup> TA350KM <sup>①</sup>	BMH3M BMH3M BMH3M BMH3M BMH3M

① Individually packed.

② Special 50°C rating available. Order by description.

③ 60% protected neutral - left pole

④ For AC application only.

Selection Guide and Ordering Information

Line and Load Terminals

K-Frame circuit breakers include Cu/Al terminals as standard. When optional copper or Cu/1919Al terminals are required, order by catalogue number.

Maximum Breaker Amperes	Terminal Body Material	Wire Type	Metric Wire Range mm <sup>2</sup>	AWG Wire Range/ Number Conductors	Catalogue Number
<b>Standard Pressure Type Terminals</b>					
225	Aluminium	Cu/Al	35-185	3-350/(1)	TA300KM <sup>①③</sup>
400	Aluminium	Cu/Al	120-240	250-500/(1)	TA350KM <sup>①③⑤</sup>
<b>Optional Copper and Cu/Al Pressure Type Terminals</b>					
225	Copper	Cu	35-185	3-350/(1)	T300K <sup>②③</sup>
400	Copper	Cu	120-240	250-500/(1)	T300K <sup>②③</sup>
400	Aluminium	Cu/Al	95-120	3/0-250/(2)	2TA400K - 2-Pole Kit <sup>②④</sup> 3TA400K - 3-Pole Kit <sup>②④</sup> 4TA400K - 4-Pole Kit <sup>②④</sup>
400	Aluminium	Cu	95-120	3/0-250/(2)	2T400K - 2-Pole Kit <sup>②④</sup> 3T400K - 3-Pole Kit <sup>②④</sup> 4T400K - 4-Pole Kit <sup>②④</sup>
400	Aluminium	Cu/Al	70-240 70-240 70-240	2/0-250/(2) or 2/0-500/(1)	2TA401K - 2-Pole Kit <sup>②④</sup> 3TA401K - 3-Pole Kit <sup>②④</sup> 4TA401K - 4-Pole Kit <sup>②④</sup>

Catalogue Number

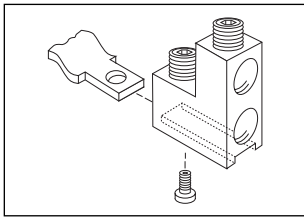

TA300KM, TA300K, T300K

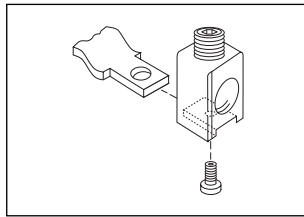

TA350KM, TA350K, T350K

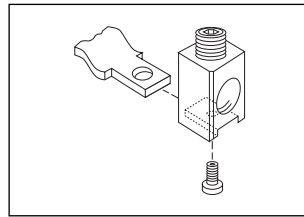

TA400K, T400K

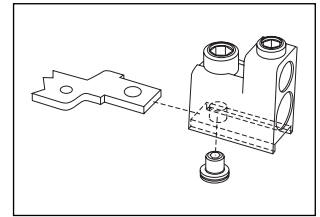

TA401K

Endcap Kit

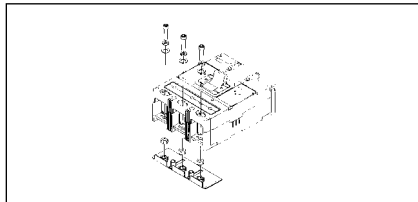

Endcap kits are used on K-Frame breaker line load to connect bus bar or similar electrical connections. Includes hardware.

Kit Catalogue Number

Metric	Imperial
KPEKM3	KPEK3

Control Wire Terminal Kit

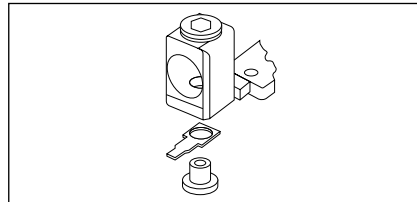

For use with aluminium or copper terminals only.

Package of 14 - Priced Individually
Catalogue Number - KCWTK

Base Mounting Hardware

Base mounting hardware is included with a circuit breaker or moulded case switch.

Number of Poles	Description	Type of Mounting	Catalogue Number
<b>Metric Thread</b>			
2, 3, 4	M6-0.7 x 38 mm Pan-Head Set screws and Lockwashers	Individual	4218B80G14
<b>Imperial Thread</b>			
2, 3, 4	0.250-20 x 1.5 Inch Pan-Head Steel Screws and Lockwashers	Individual	4218B80G14

Handle Extension

Not included with breaker. Must be purchased separately.

Packaged Individually
Catalogue Number - HEX3

Terminal Shields

Location	Number of Poles	Catalogue Number Package of 10
Line End	2, 3, 4	TS33LN TS34LN
Load End	3	TS33LD

Interphase Barriers

Package of 2
Catalogue Number - IPB3

- ① Metric hardware.
- ② Imperial hardware.
- ③ Individually packed.
- ④ TA400K, T400K, and TA401K terminal kits contain one terminal for each pole and one terminal cover.
- ⑤ Standard terminal.

Cutler-Hammer Frame Size L, 315-800 Amperes

**Selection Guide and Ordering Information**

Maximum Continuous Ampere Rating at 40°C①②	Number of Poles	Standard Interrupting Capacity Catalogue Number		High Interrupting Capacity Catalogue Number		Ultra-High Interrupting Capacity Catalogue Number		Thermal Magnetic Trip Unit Only For Use with Standard or High or Ultra-High Interrupting Frame Adjustable Thermal Adjustable Magnetic	Standard Terminals Only Catalogue Number	Metric Mounting Hardware Catalogue Number
		U <sub>e</sub> Max. 690 VAC		U <sub>e</sub> Max. 690 VAC		U <sub>e</sub> Max. 690 VAC				
		45 kA I <sub>cu</sub> at 415 VAC		70 kA I <sub>cu</sub> at 415 VAC		100 kA I <sub>cu</sub> at 415 VAC				
Factory Assembled Circuit Breaker Consisting of Frame, Trip Unit, and Terminals		Frame Only		Factory Assembled Circuit Breaker Consisting of Frame, Trip Unit, and Terminals		Frame Only				

**Adjustable Thermal Magnetic Circuit Breakers with Interchangeable Trip Units**

-		Type LW		Type HLW		Type LWC		-		
315 400 500 630	2-Pole	LW2315 LW2400 LW2500 LW2630	LW2630F	HLW2315 HLW2400 HLW2500 HLW2630	HLW2630F	LWC2315 LWC2400 LWC2500 LWC2630	LWC2630F	LT2315TA LT2400TA LT2500TA LT2630TA	TA602LDM① TA602LDM① TA602LDM① TA603LDKM③	BMH4M BMH4M BMH4M BMH4M
315 400 500 630	3-Pole	LW3315 LW3400 LW3500 LW3630	LW3630F	HLW3315 HLW3400 HLW3500 HLW3630	HLW3630F	LWC3315 LWC3400 LWC3500 LWC3630	LWC3630F	LT3315TA LT3400TA LT3500TA LT3630TA	TA602LDM① TA602LDM① TA602LDM① TA603LDKM③	BMH4M BMH4M BMH4M BMH4M
315 400 500 630	4-Pole	LW4315③ LW4400③ LW4500③	LW4630F	HLW4315 HLW4400 HLW4500	HLW4630F	LWC4315 LWC4400 LWC4500	LWC4630F	LT4315TA LT4400TA LT4500TA	TA602LDM① TA602LDM① TA602LDM①	BMH4M BMH4M BMH4M
630 500 630		LW4630④ LW4500④ LW4630④		HLW4630 HLW4500E④ HLW4630E④		LWC4630 LWC4500E④ LWC4630E④		LT4630TA LT4500TA④ LT4630TAE④	TA603LDKM③ TA602LDM① TA603LDKM③	BMH4M BMH4M BMH4M

**Thermal Magnetic Fixed Thermal Circuit Breakers with Noninterchangeable Trip Units and Bus Extension**

-		Types LW (U <sub>e</sub> Max. 690 VAC, 50 kA I <sub>cu</sub> @ 415 VAC)		-							
700 800	3-Pole	LW3700W LW3800W	-	-	-	-	-	-	-	-	BMH4M BMH4M

**Moulded Case Switches MCS Only without Line and Load Terminals**

-		Type LW (690 VAC Max.)		Type HLW (690 VAC Max.)		-					
630	2-Pole 3-Pole 4-Pole	LW2630KW LW3630WK LW4630WK	-	HLW2630KW HLW3630WK HLW4630WK	-	-	-	-	-	TA603LDKM③ TA603LDKM③ TA603LDKM③	BMH4M BMH4M BMH4M
800	3-Pole 4-Pole	LW3800WK LW4800WK	-	-	-	-	-	-	-	-	BMH4M BMH4M

**Electronic Circuit Breakers⑥**

With Interchangeable Type LES Digitrip RMS Trip Units – Order as Individual Components: Breaker Frame, Trip Unit, Rating Plug, Terminals, Mounting Hardware

Maximum Continuous Ampere Rating at 40°C①②	Number of Poles	Circuit Breaker Frame Only Catalogue Number			Digitrip RMS 310 Trip Unit Only Less Rating Plug Catalogue Number⑤				Digitrip RMS 310 Only Rating Plug Order as Individual Component			Standard Terminals Only Catalogue Number	Metric Mounting Hardware Catalogue Number
		Standard Interrupting Capacity	High Interrupting Capacity	Ultra-High Interrupting Capacity	L - Adjustable Long Delay Pickup (By Adjustable Rating Plug) S - Adjustable Short Delay Pickup with Fixed Short Delay Time (I <sup>2</sup> t Response) or Adjustable Short Delay Time (Flat Response) I - Adjustable Instantaneous Pickup by Setting Short Delay Time to Instantaneous G - Adjustable Ground Fault Pickup with Adjustable Ground Fault Delay (Flat Response)				Fixed Rating Plug		Adjustable Rating Plug		
		660 VAC Max.			LS	LSI	LSG	LSIG	Ampere Rating	Catalogue Number	Ampere Rating Catalogue Number		
		45 kA I <sub>cu</sub> at 415 VAC	70 kA I <sub>cu</sub> at 415 VAC	100 kA I <sub>cu</sub> at 415 VAC									
		Type LW	Type HLW	Type LWC									
630	3-Pole⑦	LW3630F	HLW3630F	LWC3630F	LES3630LS	LES3630LSI	LES3630LSG	LES3630LSIG	315 350 400 500 630	6LES315T 6LES350T 6LES400T 6LES500T 6LES630T	Adjustable Settings are: 315/400/500/630 A6LES630T2	TA602LDM① TA602LDM① TA602LDM① TA603LDKM① TA603LDKM③	BMH4M BMH4M BMH4M BMH4M BMH4M
	4-Pole⑧	LW4630F	HLW4630F	LWC4630F	LES4630LS	LES4630LSI	LES4630LSG	LES4630LSIG	315 350 400 500 630	6LES315T 6LES350T 6LES400T 6LES500T 6LES630T	Adjustable Settings are: 315/400/500/630 A6LES630T2	TA602LDM① TA602LDM① TA602LDM① TA603LDKM① TA603LDKM③	BMH4M BMH4M BMH4M BMH4M BMH4M

**Electronic Circuit Breakers**

Includes Circuit Breaker Frame, Digitrip RMS 310 Electronic Trip Units with Noninterchangeable Adjustable Rating Plug and Bus Extension

800	3-Pole⑦	LW3800T33W LW3800T35W LW3800T35XW	-	-	-	-	-	-	-	-	Adjustable Settings are: 400/500/630/800 A8LES800T1	-	BMH4M BMH4M BMH4M
	4-Pole⑧	LW4800T33W	-	-	-	-	-	-	-	-	-	-	BMH4M

① Individually packed.  
② Special 50°C rating available. Order by description.  
③ 2TA603KM, 3TA603LDKM and 4TA603LDKM terminal kits contain one terminal per each pole and one terminal cover.

④ 60% protected neutral – left pole  
⑤ Ampere rating is established by rating plug.  
⑥ For AC application only.  
⑦ 3-pole LES trip units are for use in 3-pole frames only.

⑧ Trip unit includes unprotected left neutral pole. For 100% protected left pole neutral add "P" to catalogue number, i.e., LES4630LSP.

### Cutler-Hammer Frame Size L, 315-800 Amperes

## Selection Guide and Ordering Information

### Line and Load Terminals

L-Frame circuit breakers include Cu/Al terminals as standard equipment. When optional copper terminals are required, order by catalogue number. 800 ampere L-Frame circuit breakers include bus extensions only.

Maximum Breaker Amperes	Terminal Body Material	Wire Type	Metric Wire Range mm <sup>2</sup>	AWG Wire Range / No. Conductors	Catalogue Number
<b>Standard Cu/Al Pressure Type Terminals</b>					
400	Aluminium	Cu/Al	120-300	4/0-600 (1)	3TA401LDKM - 3-Pole Kit <sup>①</sup> 4TA401LDKM - 4-Pole Kit <sup>②</sup>
450	Aluminium	Cu/Al	25-95 (2)	4-4/0 (2)	TA450LDM <sup>①</sup>
500	Aluminium	Cu/Al	120-150	250-350 (2)	TA602LDM <sup>①</sup>
600	Aluminium	Cu/Al	185-240 (2)	400-500 (2)	3TA603LDKM - 3-Pole Kit <sup>②</sup> 4TA603LDKM - 4-Pole Kit <sup>②</sup>
<b>Optional Copper Pressure Type Terminals</b>					
600	Copper	Copper	120-150	250-350 (2)	T602LDM <sup>①</sup>

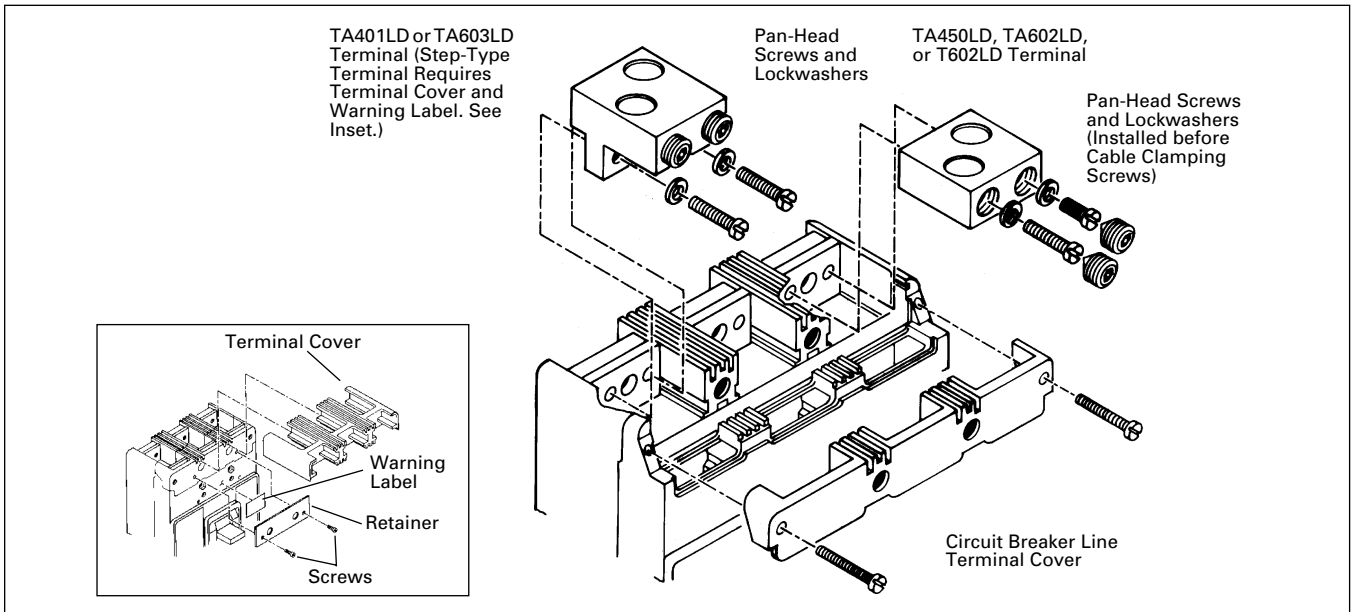

### Terminal Shields

Terminal shields provide protection against accidental contact with live line side terminations. Terminal shields are fabricated from high dielectric insulating material and fasten over the front terminal access openings. Small openings in the shields provide limited access to the terminals for tightening connectors. (Field installation only.)

Package of 2
Style Number – 314C420G01

### Handle Extension

Not included with breaker. Must be purchased separately.

Packaged Individually
Catalogue Number – HEX4

### Keeper Nut

Not required on L-Frame. Terminal is threaded.

<sup>①</sup> Individually packed.  
<sup>②</sup> Terminal kits contain one terminal for each pole and one terminal cover.

### Base Mounting Hardware

Base mounting hardware is included with a circuit breaker or moulded case switch.

Number of Poles	Description	Type of Mounting	Style Number
<b>Metric Thread</b>			
2, 3	0.250-20 x	Individual	5103A09G01
<b>Imperial Thread</b>			
2, 3, 4	0.250-20 x 1.5 Inch Filister-Head Steel Screws and Lock-washers and Flat Washers	Individual	21C6782G05

### Kit Catalogue Number

Metric	Imperial
KPEKM4	KPEK4

### Interphase Barriers

The interphase barriers provide additional electrical clearance between circuit breaker poles for special termination applications. The barriers are high dielectric insulating plates that are installed in the moulded slots

between the terminals. (Field installation only.) Two per package.

Package of 2
Catalogue Number – IPB4

### Endcap Kit

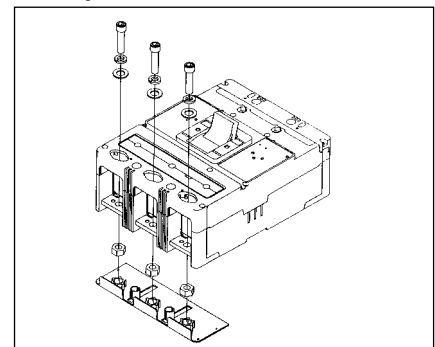

Endcap kits are used on L-Frame breaker line load to connect bus bar or similar electrical connections. Includes hardware.

### Kit Catalogue Number

Metric	Imperial
KPEKM4	KPEK4



Cutler-Hammer Frame Size N, 400-1250 Amperes 50 kA at 415 VAC

### Selection Guide and Ordering Information

Maximum Continuous Ampere Rating at 40°C <sup>①②</sup>	Number of Poles	Circuit Breaker Frame Including Digitrip RMS 310 Electronic Trip Unit Less Rating Plugs and Terminals Order as Individual Component – Catalogue Number <sup>③</sup>				Digitrip RMS 310 Interchangeable Rating Plugs Order as Individual Component		
		LS	LSI	LSG	LSIG	Fixed Rating Plug		Adjustable Rating Plug
						Ampere Rating	Catalogue Number	Ampere Rating Catalogue Number
–	–	LS	LSI	LSG	LSIG	–	–	–
Short Time Range	–	2-8 x I <sub>n</sub>	2-8 x I <sub>n</sub>	2-8 x I <sub>n</sub>	2-8 x I <sub>n</sub>	–	–	–
Short Time Delay	–	–	0-300 ms	–	0-300 ms	–	–	–
Ground Fault Pickup	–	–	–	200-1200A	200-1200A	–	–	–
Ground Fault Delay	–	–	–	0-500 ms	0-500 ms	–	–	–

Type NW Standard Interrupting Capacity – U<sub>e</sub> Max. 690 VAC, 50 kA I<sub>cu</sub> at 415 VAC

800	2-Pole	NW2800T33W	NW2800T32W	NW2800T35W	NW2800T36W	400 450 500 550 600 630 700 800	8NES400T 8NES450T 8NES500T 8NES550T 8NES600T 8NES630T 8NES700T 8NES800T	Adjustable Settings Are: 400/500/630/800 8NES800T2
	3-Pole	NW3800T33W	NW3800T32W	NW3800T35W	NW3800T36W	400 450 500 550 600 630 700 800	8NES400T 8NES450T 8NES500T 8NES550T 8NES600T 8NES630T 8NES700T 8NES800T	400/500/630/800 8NES800T2
	4-Pole	NW4800T33W	NW4800T32W	–	–	400 450 500 550 600 630 700 800	8NES400T 8NES450T 8NES500T 8NES550T 8NES600T 8NES630T 8NES700T 8NES800T	400/500/630/800 8NES800T2
1250	2-Pole	NW2125T33W	NW2125T32W	NW2125T35W	NW2125T36W	600 630 700 800 900 1000 1200 1250	12NES600T 12NES630T 12NES700T 12NES800T 12NES900T 12NES1000T 12NES1200T 12NES1250T	630/800/1000/1250 A12NES1250T2
	3-Pole	NW3125T33W	NW3125T32W	NW3125T35W	NW3125T36W	600 630 700 800 900 1000 1200 1250	12NES600T 12NES630T 12NES700T 12NES800T 12NES900T 12NES1000T 12NES1200T 12NES1250T	630/800/1000/1250 A12NES1250T2
	4-Pole	NW4125T33W	NW4125T32W	–	–	600 630 700 800 900 1000 1200 1250	12NES600T 12NES630T 12NES700T 12NES800T 12NES900T 12NES1000T 12NES1200T 12NES1250T	630/800/1000/1250 A12NES1250T2

### Moulded Case Switches<sup>①③</sup>

Ampere Rating	Number of Poles	U <sub>e</sub> Max. 690 VAC Catalogue Number	
800	3-Pole	NW3800WK	MCS Only without Line and Load
	4-Pole	NW4800WK	
1250	3-Pole	NW3125WK	MCS Only without Line and Load
	4-Pole	NW4125WK	
800	3-Pole	HNW3800WK	MCS Only without Line and Load
	4-Pole	HNW4800WK	
1250	3-Pole	HNW3125WK	MCS Only without Line and Load
	4-Pole	HNW4125WK	

① For AC use only.

② Special 50°C rating available. Order by description.

③ For 2-pole applications, use outer poles of 3-pole moulded case switch.

④ Order rating plug and terminals separately.



Selection Guide and Ordering Information

Maximum Continuous Ampere Rating at 40°C①②	Number of Poles	Circuit Breaker Frame Including Digitrip RMS 310 Electronic Trip Unit Less Rating Plugs and Terminals Order as Individual Component – Catalogue Number③				Digitrip RMS 310 Interchangeable Rating Plugs Order as Individual Component		
		L - Adjustable Long Delay Pickup (By Adjustable Rating Plug) S - Adjustable Short Delay Pickup with Fixed Short Delay Time (I <sup>2</sup> t Response) or Adjustable Short Delay Time (Flat Response) I - Adjustable Instantaneous Pickup by Setting Short Delay Time to Instantaneous G - Adjustable Ground Fault Pickup with Adjustable Ground Fault Delay (Flat Response)	Fixed Rating Plug		Adjustable Rating Plug			
			Ampere Rating	Catalogue Number	Ampere Rating	Catalogue Number		
–	–	LS	LSI	LSG	LSIG	–	–	–
Short Time Range	–	2-8 x I <sub>n</sub>	2-8 x I <sub>n</sub>	2-8 x I <sub>n</sub>	2-8 x I <sub>n</sub>	–	–	–
Short Time Delay	–	–	0-300 ms	–	0-300 ms	–	–	–
Ground Fault Pickup	–	–	–	200-1200A	200-1200A	–	–	–
Ground Fault Delay	–	–	–	0-500 ms	0-500 ms	–	–	–

Type HNWS Standard Interrupting Capacity – U<sub>e</sub> Max. 690 VAC, 70 kA I<sub>cu</sub> at 415 VAC

800	2-Pole	HNW2800T33W	HNW2800T32W	HNW2800T35W	HNW2800T36W	400 450 500 550  600 630 700 800	8NES400T 8NES450T 8NES500T 8NES550T  8NES600T 8NES630T 8NES700T 8NES800T	Adjustable Settings Are: 400/500/630/800 8NES800T2	
	3-Pole	HNW3800T33W	HNW3800T32W	HNW3800T35W	HNW3800T36W	400 450 500 550  600 630 700 800	8NES400T 8NES450T 8NES500T 8NES550T  8NES600T 8NES630T 8NES700T 8NES800T		400/500/630/800 8NES800T2
	4-Pole	HNW4800T33W	HNW4800T32W	–	–	400 450 500 550  600 630 700 800	8NES400T 8NES450T 8NES500T 8NES550T  8NES600T 8NES630T 8NES700T 8NES800T		400/500/630/800 8NES800T2
1250	2-Pole	HNW2125T33W	HNW2125T32W	HNW2125T35W	HNW2125T36W	600 630 700 800  900 1000 1200 1250	12NES600T 12NES630T 12NES700T 12NES800T  12NES900T 12NES1000T 12NES1200T 12NES1250T	630/800/1000/1250 A12NES1250T2	
	3-Pole	HNW3125T33W	HNW3125T32W	HNW3125T35W	HNW3125T36W	600 630 700 800  900 1000 1200 1250	12NES600T 12NES630T 12NES700T 12NES800T  12NES900T 12NES1000T 12NES1200T 12NES1250T		630/800/1000/1250 A12NES1250T2
	4-Pole	HNW4125T33W	HNW4125T32W	–	–	600 630 700 800  900 1000 1200 1250	12NES600T 12NES630T 12NES700T 12NES800T  12NES900T 12NES1000T 12NES1200T 12NES1250T		630/800/1000/1250 A12NES1250T2

① For AC use only.  
② Special 50°C rating available.  
Order by description.  
③ Order rating plug and terminals separately.

Cutler-Hammer Frame Size N, 400-1250 Amperes 100 kA

### Selection Guide and Ordering Information

Maximum Continuous Ampere Rating at 40°C <sup>①②</sup>	Number of Poles	Circuit Breaker Frame Including Digitrip RMS 310 Electronic Trip Unit Less Rating Plugs and Terminals Order as Individual Component – Catalogue Number <sup>③</sup>				Digitrip RMS 310 Interchangeable Rating Plugs Order as Individual Component			
		L - Adjustable Long Delay Pickup (By Adjustable Rating Plug) S - Adjustable Short Delay Pickup with Fixed Short Delay Time (I <sup>2</sup> t Response) or Adjustable Short Delay Time (Flat Response) I - Adjustable Instantaneous Pickup by Setting Short Delay Time to Instantaneous G - Adjustable Ground Fault Pickup with Adjustable Ground Fault Delay (Flat Response)	LS	LSI	LSG	LSIG	Fixed Rating Plug		Adjustable Rating Plug
			Ampere Rating	Catalogue Number	Ampere Rating	Catalogue Number			
–	–	LS	LSI	LSG	LSIG	–	–	–	
Short Time Range		2-8 x I <sub>n</sub>	2-8 x I <sub>n</sub>	2-8 x I <sub>n</sub>	2-8 x I <sub>n</sub>				
Short Time Delay		–	0-300 ms	–	0-300 ms				
Ground Fault Pickup		–	–	200-1200A	200-1200A				
Ground Fault Delay		–	–	0-500 ms	0-500 ms				

#### Type NWC Standard Interrupting Capacity – U<sub>e</sub> Max. 690 VAC, 100 kA I<sub>cu</sub> at 415 VAC

800	2-Pole	NWC2800T33W	NWC2800T32W	NWC2800T35W	NWC2800T36W	400	8NES400T 8NES450T 8NES500T 8NES550T	Adjustable Settings Are: 400/500/630/800 8NES800T2
						450		
						500		
	550							
	600	8NES600T 8NES630T 8NES700T 8NES800T						
	630							
	700							
	700	8NES700T 8NES800T						
	800							
800								
3-Pole	NWC3800T33W	NWC3800T32W	NWC3800T35W	NWC3800T36W	400	8NES400T 8NES450T 8NES500T 8NES550T	400/500/630/800 8NES800T2	
					450			
					500			
550								
600	8NES600T 8NES630T 8NES700T 8NES800T							
630								
700								
700	8NES700T 8NES800T							
800								
800								
1250	2-Pole	NWC2125T33W	NWC2125T32W	NWC2125T35W	NWC2125T36W	600	12NES600T 12NES630T 12NES700T 12NES800T	630/800/1000/1250 A12NES1250T2
						630		
						700		
	700							
	800	12NES900T 12NES1000T 12NES1200T 12NES1250T						
	900							
	1000							
	1000	12NES1000T 12NES1200T 12NES1250T						
	1200							
1250								
3-Pole	NWC3125T33W	NWC3125T32W	NWC3125T35W	NWC3125T36W	600	12NES600T 12NES630T 12NES700T 12NES800T	630/800/1000/1250 A12NES1250T2	
					630			
					700			
700								
800	12NES900T 12NES1000T 12NES1200T 12NES1250T							
900								
1000								
1000	12NES1000T 12NES1200T 12NES1250T							
1200								
1250								
4-Pole	NWC4125T33W	NWC4125T32W	–	–	600	12NES600T 12NES630T 12NES700T 12NES800T	630/800/1000/1250 A12NES1250T2	
					630			
					700			
700								
800	12NES900T 12NES1000T 12NES1200T 12NES1250T							
900								
1000								
1000	12NES1000T 12NES1200T 12NES1250T							
1200								
1250								

① For AC use only.

② Special 50°C rating available.  
Order by description.

③ Order rating plug and terminals separately.

**Cutler-Hammer Frame Size N, 400-1250 Amperes**

**Selection Guide and Ordering Information**

**Line and Load Terminals**

N-Frame circuit breakers include Cu/Al terminals as standard. When optional copper or Cu/Al terminals are required, order by catalogue number.

Maximum Breaker Amperes	Terminal Body Material	Wire Type	Metric Wire Range mm <sup>2</sup>	AWG Wire Number of Conductors	Catalogue Number
<b>Standard Cu/Al Pressure-Type Terminals</b>					
1250	Aluminium	Cu/Al	120-300	4/0-500 (3)	TA1200NB3M
<b>Optional Copper and Cu/Al Pressure Type Terminals</b>					
1250	Copper	Copper	95-185	3/0-400 (4)	T1200NB3M

**Base Mounting Hardware**

Base mounting hardware is included with a circuit breaker or moulded case switch.

**Imperial Thread**

Number of Poles	Description	Catalogue Number
2-, 3-, and 4-pole	0.3125-18 x 1.25 Inch Pan-Head Steel Screws and Lock Washers	BMH5M

**Keeper Nut**

Not required on N-Frame. Terminals are threaded.

**Handle Extension**

Included with breaker. Additional handle extensions are available.

<b>Single Handle Extension</b>
Catalogue Number – HEX5

**Interphase Barriers**

The interphase barriers provide additional electrical clearance between circuit breaker poles for special termination applications. Barriers are high dielectric insulating plates that are installed in the Moulded slots between the terminals. (Field installation only.)

<b>Interphase Barriers</b>
Catalogue Number – IPB5

Cutler-Hammer Frame Size R, 800-2500 Amperes 70 kA at 415 VAC

### Selection Guide and Ordering Information

Maximum Continuous Ampere Rating at 40°C <sup>①②</sup>	Number of Poles	Circuit Breaker Frame Including Digitrip RMS 310 Electronic Trip Unit Less Rating Plugs and Terminals Order as Individual Component – Catalogue Number <sup>⑤</sup>				Digitrip RMS 310 Interchangeable Rating Plugs Order as Individual Component		
		L - Adjustable Long Delay Pickup (By Adjustable Rating Plug) S - Adjustable Short Delay Pickup with Fixed Short Delay Time (I <sup>2</sup> t Response) or Adjustable Short Delay Time (Flat Response) I - Adjustable Instantaneous Pickup by Setting Short Delay Time to Instantaneous G - Adjustable Ground Fault Pickup with Adjustable Ground Fault Delay (Flat Response)	Fixed Rating Plug		Adjustable Rating Plug			
			Ampere Rating	Catalogue Number	Ampere Rating	Catalogue Number		
–	–	LS	LSI	LSG <sup>④</sup>	LSIG <sup>③</sup>	–	–	–
Short Time Range		2-8 x I <sub>n</sub>	2-8 x I <sub>n</sub>	2-8 x I <sub>n</sub>	2-8 x I <sub>n</sub>			
Short Time Delay		–	0-300 ms	–	0-300 ms			
Ground Fault Pickup		–	–	200-1200A	200-1200A			
Ground Fault Delay		–	–	0-500 ms	0-500 ms			

#### Type RW with Digitrip 310 Standard Interrupting Capacity – U<sub>e</sub> Max. 690 VAC, 70 kA I<sub>cu</sub> at 415 VAC

1600 <sup>①</sup>	3-Pole	RW316T33W	RW316T32W	RW316T35W	RW316T36W	800 1000 1200 1250	16RES08T 16RES10T 16RES12T 16RES125T	Adjustable Settings Are: 800/1000/1200/1600 A16RES16T1
						1400 1500 1600	16RES14T 16RES15T 16RES16T	
2000		RW320T33W	RW320T32W	RW320T35W	RW320T36W	1000 1200 1250	20RES10T 20RES12T A20RES125T	1000/1200/1600/2000 A20RES20T1
					1400 1600 2000	A20RES14T A20RES16T A20RES20T	1000/1250/1600/2000 A20RES20T2	
2500		RW325T33W	RW325T32W	RW325T35W	RW325T36W	1200 1250 1600 2000 2500	25RES12T 25RES125T A25RES16T A25RES20T A25RES25T	1200/1600/2000/2500 A25RES25T1 1250/1600/2000/2500 A25RES25T2
1600 <sup>①</sup>	4-Pole <sup>③</sup>	RW416T33W	RW416T32W	–	–	800 1000 1200 1250	16RES08T 16RES10T 16RES12T 16RES125T	800/1000/1200/1600 A16RES16T1
						1400 1500 1600	16RES14T 16RES15T 16RES16T	
2000		RW420T33W	RW420T32W	–	–	1000 1200 1250	20RES10T 20RES12T A20RES125T	1000/1200/1600/2000 A20RES20T1
					1400 1600 2000	A20RES14T A20RES16T A20RES20T	1000/1250/1600/2000 A20RES20T2	
2500		RW425T33W	RW425T32W	–	–	1200 1250 1600 2000 2500	25RES12T 25RES125T A25RES16T A25RES20T A25RES25T	1200/1600/2000/2500 A25RES25T1 1250/1600/2000/2500 A25RES25T2

① For SCR application, use 2000A frame.

② Special 50°C rating available. Order by description.

③ Unprotected left pole neutral. Add "P" to catalogue number for 100% protected left pole neutral, add "E" for 60% protected, i.e., "RW416T33PW", "RW416T33EW".

④ Ground fault equipped trip units available with remote indicating panel. Add "R" to catalogue number, i.e., "RW316T35RW".

⑤ Order rating plug and terminals separately. Mounting hardware not included.

Selection Guide and Ordering Information

Maximum Continuous Ampere Rating at 40°C <sup>①②</sup>	Number of Poles	Circuit Breaker Frame Including Digitrip RMS 310 Electronic Trip Unit Less Rating Plugs and Terminals Order as Individual Component – Catalogue Number <sup>⑤</sup>				Digitrip RMS 310 Interchangeable Rating Plugs Order as Individual Component		
		L - Adjustable Long Delay Pickup (By Adjustable Rating Plug) S - Adjustable Short Delay Pickup with Fixed Short Delay Time (I <sup>2</sup> t Response) or Adjustable Short Delay Time (Flat Response) I - Adjustable Instantaneous Pickup by Setting Short Delay Time to Instantaneous G - Adjustable Ground Fault Pickup with Adjustable Ground Fault Delay (Flat Response)	Fixed Rating Plug		Adjustable Rating Plug			
			Ampere Rating	Catalogue Number	Ampere Rating	Catalogue Number		
–	–	LS	LSI	LSG <sup>④</sup>	LSIG <sup>④</sup>	–	–	–
Short Time Range	–	2-8 x I <sub>n</sub>	2-8 x I <sub>n</sub>	2-8 x I <sub>n</sub>	2-8 x I <sub>n</sub>	–	–	–
Short Time Delay	–	–	0-300 ms	–	0-300 ms	–	–	–
Ground Fault Pickup	–	–	–	200-1200A	200-1200A	–	–	–
Ground Fault Delay	–	–	–	0-500 ms	0-500 ms	–	–	–

Type RWC with Digitrip 310 High Interrupting Capacity – U<sub>e</sub> Max. 690 VAC, 100 kA I<sub>cu</sub> at 415 VAC

Maximum Continuous Ampere Rating	Number of Poles	LS	LSI	LSG <sup>④</sup>	LSIG <sup>④</sup>	Fixed Rating Plug	Adjustable Rating Plug	
1600 <sup>①</sup>	3-Pole	RWC316T33W	RWC316T32W	RWC316T35W	RWC316T36W	800 1000 1200 1250  1400 1500 1600	16RES08T 16RES10T 16RES12T 16RES125T  16RES14T 16RES15T 16RES16T	Adjustable Settings Are: 800/1000/1200/1600 A16RES16T1  800/1000/1250/1600 A16RES16T2
2000		RWC320T33W	RWC320T32W	RWC320T35W	RWC320T36W	1000 1200 1250  1400 1600 2000	20RES10T 20RES12T A20RES125T  A20RES14T A20RES16T A20RES20T	1000/1200/1600/2000 A20RES20T1  1000/1250/1600/2000 A20RES20T2
1600 <sup>①</sup>	4-Pole <sup>③</sup>	RWC416T33W	RWC416T32W	–	–	800 1000 1200 1250  1400 1500 1600	16RES08T 16RES10T 16RES12T 16RES125T  16RES14T 16RES15T 16RES16T	800/1000/1200/1600 A16RES16T1  800/1000/1250/1600 A16RES16T2
2000		RWC420T33W	RWC420T32W	–	–	1000 1200 1250  1400 1600 2000	20RES10T 20RES12T A20RES125T  A20RES14T A20RES16T A20RES20T	1000/1200/1600/2000 A20RES20T1  1000/1250/1600/2000 A20RES20T2

Moulded Case Switches

Ampere Rating	Number of Poles	Catalogue Number
1600A 2000A	3-Pole	RW316WK RW320WK
1600A 2000A	4-Pole	RW416WK RW420WK

① For SCR application, use 2000A frame.

② Special 50°C rating available.  
Order by description.

③ Unprotected left pole neutral. Add "P" to catalogue number for 100% protected left pole neutral, add "E" for 60% protected, i.e., "RW416T33PW", "RW416T33EW".

④ Ground fault equipped trip units available with remote indicating panel. Add "R" to catalogue number, i.e., "RW316T35RW".

⑤ Order rating plug and terminals separately. Mounting hardware not included.

Cutler-Hammer Frame Size R, 800-1250 Amperes 70 kA at 415 VAC and 100 kA at 415 VAC

### Selection Guide and Ordering Information

Maximum Continuous Ampere Rating at 40°C <sup>①</sup>	Number of Poles	Circuit Breaker Frame Including Digitrip 610 and and 910 Electronic Trip Unit Less Rating Plugs and Terminals Order as Individual Component – Catalogue Number <sup>②</sup>					Digitrip RMS Interchangeable Rating Plug Order as Individual Component		
		L - Adjustable Long Delay Pickup ( $I_r$ ) with Adjustable Long Delay Time	S - Adjustable Short Delay Pickup with Adjustable Short Delay Time ( $I^2t$ or Flat Response)	I - Adjustable Instantaneous Pickup	G - Adjustable Ground Fault Pickup with Adjustable Ground Fault Time Delay ( $I^2t$ or Flat Response)	Fixed Rating Plug	Ampere Rating	Catalogue Number	
–	–	LI	LS	LSI	LIG	LSG	LSIG	–	–
Long Delay Pickup		$0.5-1.0 \times I_n$	$0.5-1.0 \times I_n$	$0.5-1.0 \times I_n$	$0.5-1.0 \times I_n$	$0.5-1.0 \times I_n$	$0.5-1.0 \times I_n$		
Long Delay Time		2-24 Seconds	2-24 Seconds	2-24 Seconds	2-24 Seconds	2-24 Seconds	2-24 Seconds		
Short Time Range		$2-6 \times I_r$	$2-6 \times I_r$	$2-6 \times I_r$	$2-6 \times I_r$	$2-6 \times I_r$	$2-6 \times I_r$		
Short Time Delay		–	100-500 ms	100-500 ms	–	100-500 ms	100-500 ms		
Instantaneous		$2-6 \times M1$ & $M2$	–	$2-6 \times M1$ & $M2$	$2-6 \times M1$ & $M2$	–	$2-6 \times M1$ & $M2$		
Ground Fault Pickup		–	–	–	$0.25-1.0 \times I_n$ <sup>③</sup>	$0.25-1.0 \times I_n$ <sup>③</sup>	$0.25-1.0 \times I_n$ <sup>③</sup>		
Ground Fault Delay		–	–	–	100-500 ms	100-500 ms	100-500 ms		

#### Type RW with Digitrip 610 Standard Interrupting Capacity – $U_e$ Max. 690 VAC, 70 kA $I_{cu}$ at 415 VAC

Rating	Poles	LI	LS	LSI	LIG	LSG	LSIG	Rating	Ordering
1600	3-Pole	RW316T61W	RW316T63W	RW316T62W	RW316T64W	RW316T65W	RW316T66W	800 1000 1200 1250 1600	RP6R16A080 RP6R16A100 RP6R16A120 RP6R16A125 RP6R16A160
2000		RW320T61W	RW320T63W	RW320T62W	RW320T64W	RW320T65W	RW320T66W	1000 1200 1250 1600 2000	RP6R20A100 RP6R20A120 RP6R20A125 RP6R20A160 RP6R20A200
2500		RW325T61W	RW325T63W	RW325T62W	RW325T64W	RW325T65W	RW325T66W	1600 2000 2500	RP6R25A160 RP6R25A200 RP6R25A250

#### Type RWC with Digitrip 610 High Interrupting Capacity – $U_e$ Max. 690 VAC, 100 kA $I_{cu}$ at 415 VAC

Rating	Poles	LI	LS	LSI	LIG	LSG	LSIG	Rating	Ordering
1600	3-Pole	RWC316T61W	RWC316T63W	RWC316T62W	RWC316T64W	RWC316T65W	RWC316T66W	800 1000 1200 1250 1600	RP6R16A080 RP6R16A100 RP6R16A120 RP6R16A125 RP6R16A160
2000		RWC320T61W	RWC320T63W	RWC320T62W	RWC320T64W	RWC320T65W	RWC320T66W	1000 1200 1250 1600 2000	RP6R20A100 RP6R20A120 RP6R20A125 RP6R20A160 RP6R20A200

#### Type RW with Digitrip 910 Standard Interrupting Capacity – $U_e$ Max. 690 VAC, 70 kA $I_{cu}$ at 415 VAC

Rating	Poles	LI	LS	LSI	LIG	LSG	LSIG	Rating	Ordering
1600	3-Pole	RW316T91W	RW316T93W	RW316T92W	RW316T94W	RW316T95W	RW316T96W	800 1000 1200 1250 1600	RP6R16A080 RP6R16A100 RP6R16A120 RP6R16A125 RP6R16A160
2000		RW320T91W	RW320T93W	RW320T92W	RW320T94W	RW320T95W	RW320T96W	1000 1200 1250 1600 2000	RP6R20A100 RP6R20A120 RP6R20A125 RP6R20A160 RP6R20A200
2500		RW325T91W	RW325T93W	RW325T92W	RW325T94W	RW325T95W	RW325T96W	1600 2000 2500	RP6R25A160 RP6R25A200 RP6R25A250

#### Type RWC with Digitrip 910 High Interrupting Capacity – $U_e$ Max. 690 VAC, 100 kA $I_{cu}$ at 415 VAC

Rating	Poles	LI	LS	LSI	LIG	LSG	LSIG	Rating	Ordering
1600	3-Pole	RWC316T91W	RWC316T93W	RWC316T92W	RWC316T94W	RWC316T95W	RWC316T96W	800 1000 1200 1250 1600	RP6R16A080 RP6R16A100 RP6R16A120 RP6R16A125 RP6R16A160
2000		RWC320T91W	RWC320T93W	RWC320T92W	RWC320T94W	RWC320T95W	RWC320T96W	1000 1200 1250 1600 2000	RP6R20A100 RP6R20A120 RP6R20A125 RP6R20A160 RP6R20A200

① Special 50°C rating available. Order by description.

② Order rating plug and terminals separately. Mounting hardware not included.

③ Not to exceed 1200A ground fault pick-up.

Selection Guide and Ordering Information

Line and Load Terminals

R-Frame circuit breakers have Cu/Al terminals as standard and copper only terminals as an option. Specify if factory installation is required.

Maximum Breaker Amperes	Terminal Body Material	Wire Type	Hardware	AWG/kmil Wire Range/Number of Conductors	Metric Wire Range mm <sup>2</sup>	Catalogue Number
-------------------------	------------------------	-----------	----------	--	-----------------------------------	------------------

Wire Terminals

1600	Aluminium	Cu/Al	English	500-1000 (4)	300-500	TA1600RD
1600	Copper	Cu	English	1-600 (4)	50-300	T1600RD
2000	Aluminium	Cu/Al	English	2-600 (6)	35-300	TA2000RD

Rear Connectors

2000	Copper	-	English	-	-	B2016RD
2000	Copper	-	English	-	-	B2016RDL
2500	Copper	-	English	-	-	B2500RD

RD Rear Connector Exploded View

TA2000RD<sup>①</sup>

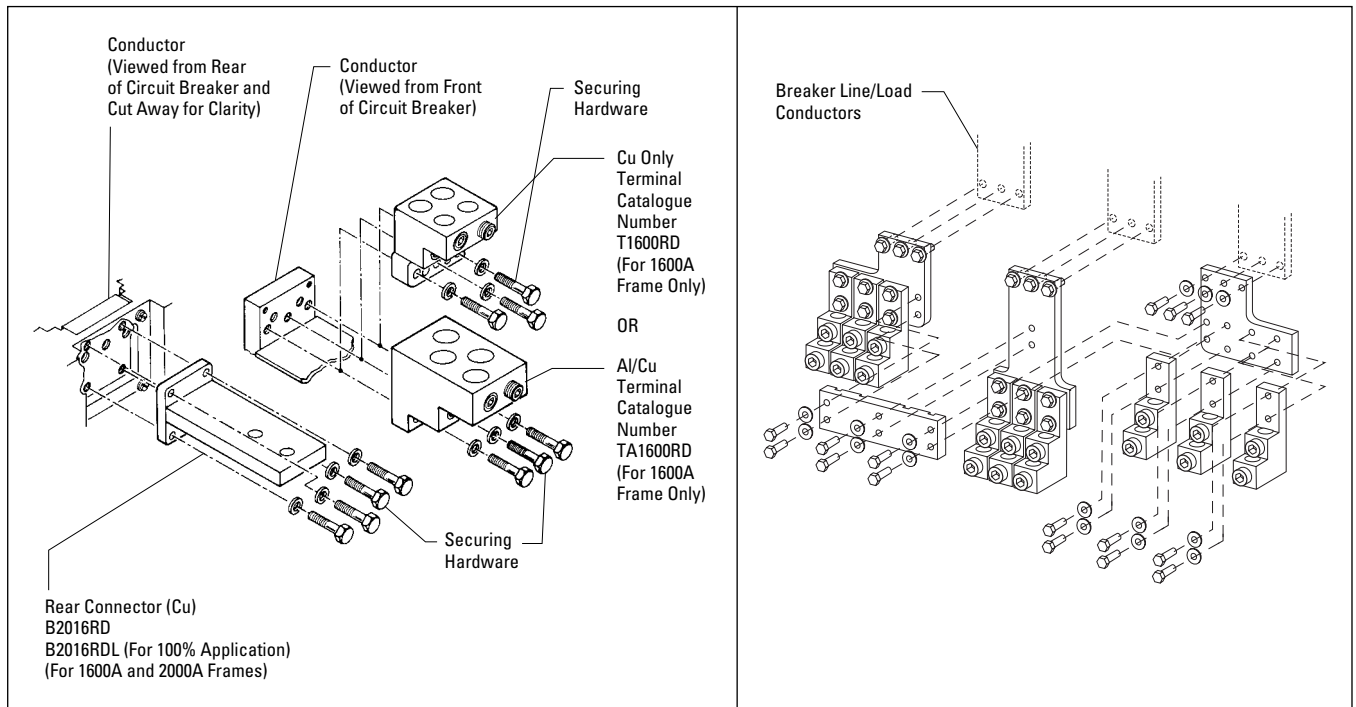

Base Mounting Hardware

Supplied by customer.

Handle Extension

Included with breaker. Additional handle extensions are available.

Single Handle Extension
Catalogue Number – HEX6

<sup>①</sup> Catalogue number includes bus connection, terminals, and hardware for either line side or load side of 3-pole breaker.



## Motor Circuit Protectors

### Selection Guide and Ordering Information

#### Circuit Breakers for Motor Protection

Breaker Type	Rated Current $I_n$	Rated Output of 3-Phase Motors <sup>①</sup> to Be Protected at 50 Hz		Setting Current of Inverse-Time Overload Release $I_r$	Instantaneous Short Circuit Release $I_i$	Trip Class $T_c$	Standard Switching Capacity Catalogue Number	High Switching Capacity Catalogue Number
		380/415V Max. kW	500V Max. kW					

#### Without Adjustment of the Trip Class, without Phase Unbalance Detection

Breaker Type	Rated Current $I_n$	380/415V Max. kW	500V Max. kW	Setting Current of Inverse-Time Overload Release $I_r$	Instantaneous Short Circuit Release $I_i$	Trip Class $T_c$	40 kA at 380/415 VAC	70 kA at 380/415 VAC
							Standard Switching Capacity Catalogue Number	High Switching Capacity Catalogue Number
FWMP	80	37	55	40-80	$15 \times I_r$	10	FWMP3080L	HFWMP3080L
FWMP	100	45	55	80-100	$15 \times I_r$	10	FWMP3100L	HFWMP3100L
FWMP	160	75	110	100-160	$15 \times I_r$	10	FWMP3160L	HFWMP3160L
FWMP	205	110	132	160-205	$13 \times I_r$	10	FWMP3205L	HFWMP3205L
KWMP	315	160	200	160-315	$15 \times I_r$	20	KWMP3315W	HKWMP3315W
LWMP	500	250	355	250-500	$15 \times I_r$	20	LWMP3500W	HLWMP3500W

#### With Adjustment of the Trip Class, with Phase Unbalance Detection

Breaker Type	Rated Current $I_n$	380/415V Max. kW	500V Max. kW	Setting Current of Inverse-Time Overload Release $I_r$	Instantaneous Short Circuit Release $I_i$	Trip Class $T_c$	35 kA at 380/415 VAC	65 kA at 380/415 VAC
							Standard Switching Capacity Catalogue Number	High Switching Capacity Catalogue Number
FWMP-J	80	37	55	40-80	$15 \times I_r$	5/10/15/20	FWMP3080JL	HFWMP3080JL
FWMP-J	100	45	55	80-100	$15 \times I_r$	5/10/15/20	FWMP3100JL	HFWMP3100JL
FWMP-J	160	75	110	100-160	$15 \times I_r$	5/10/15/20	FWMP3160JL	HFWMP3160JL
FWMP-J	205	110	132	160-205	$13 \times I_r$	10	FWMP3205JL	HFWMP3205JL
KWMP-J	315	160	200	160-315	$15 \times I_r$	10/15/20/30	KWMP3315JW	HKWMP3315JW
LWMP-J	500	250	355	250-500	$15 \times I_r$	20	LWMP3500JW	HLWMP3500JW

#### Motor Circuit Protectors for Combination Starters

Breaker Type	Rated Current $I_n$	380/415V Max. kW	500V Max. kW	Setting Current of Inverse-Time Overload Release $I_r$	Instantaneous Short Circuit Release $I_i$	Trip Class $T_c$	35 kA at 380/415 VAC	65 kA at 380/415 VAC <sup>①</sup>
							Standard Switching Capacity Catalogue Number	High Switching Capacity Catalogue Number
HMCP	Up to 63	30	37	—	300-1000	—	—	HMCPJ250R3
HMCP	Up to 100	45	55	—	450-1500	—	—	HMCPJ250C5
HMCP	Up to 150	75	110	—	750-1500	—	—	HMCPJ250G5
HMCP	Up to 125	55	75	—	1000-2000	—	—	HMCPJ250K5
HMCP	Up to 160	75	110	—	1125-2250	—	—	HMCPJ250L5
HMCP	Up to 200	90	132	—	1250-2500	—	—	HMCPJ250W5
HMCP	Up to 200	90	132	—	1500-3000	—	—	HMCP400N5
HMCP	Up to 250	110	160	—	1750-3500	—	—	HMCP400R5
HMCP	Up to 315	160	200	—	2000-4000	—	—	HMCP400X5
HMCP	Up to 315	160	200	—	1800-6000	—	—	HMCP600L6W
HMCP	Up to 400	200	250	—	1800-6000	—	—	HMCP600L6W
HMCP	Up to 500	250	355	—	1800-6000	—	—	HMCP600L6W

① Combination ratings with Cutler-Hammer Freedom® / ADVANTAGE® Control, contact Cutler-Hammer.

**Selection Guide and Ordering Information**

**Special Calibration**

Special non-UL listed calibrations are available for certain ambient temperatures other than 40°C and for frequencies other than 50/60 Hz or dc. Reduced interrupting ratings will apply for 400 Hz applications.

**50°C Calibration<sup>①</sup>**

Add suffix "V" to catalogue number for complete breaker when ordering listed ampere ratings for breakers to be used in 50°C ambients.

Contact Cutler-Hammer for availability.

**Moisture-Fungus Treatment**

All Cutler-Hammer Circuit Breaker cases are moulded from glass-poly-ester which does not support the growth of fungus. Any parts which are susceptible to the growth of fungus will require special treatment.

Order by description.

Accessory	Frame						
	G	E125	J250	K	L	N	R
Special Calibration	✓	✓	✓	✓	✓	✓	✓
Moisture-Fungus Treatment	✓	✓	✓	✓	✓	✓	✓

Accessory	Fit Type	Frame						
		G	E125	J250	K	L	N	R

**External Accessory Catalogue Numbers**

Non-Padlockable Handle Block	Field Fitted	1294C01H01	EFHB	–	LKD3	LKD4	LKD4	–
Padlockable Handle Block	Field Fitted	–	–	–	–	–	–	–
	Field Fitted	223C77G03	EFPHB0FF	FJPHB0FF	PHB3	–	–	HLK6
Padlockable Handle Lock Hasp	Field Fitted	–	EFPHL0FF	FJPHL0FF	PLK3	HLK4	PLK5	–
Cylinder Lock	Factory Fitted	Order by Description						
Key Interlock Kit (Provision Only)	Field Fitted	–	–	KYKFJ	KYK3	KYK4	KYK4	KYK6
Slide Bar Interlock – Requires 2 Breakers	Field Fitted	–	–	–	SBK3	SBK4	SBK5	–
Walking Beam Interlock – Requires 2 Breakers	Factory Fitted	Order by Description						
Electrical Operator	120 VAC	–	–	–	E0P3T07	E0P4T07	E0P5T07	E0P6T08
	240 VAC	–	–	–	E0P3T11	E0P4T11	E0P5T11	E0P6T11
	120 VDC	–	–	–	E0P3T07DC	E0P4T26	–	–
	240 VDC	–	–	–	E0P3T11DC	–	–	–
	24 VDC	–	–	–	MOP3PO3DC	E0P4MT21	E0P5T21K	E0P6T19K
	48 VDC	–	–	–	–	–	E0P5T22	E0P6T21
	125 VDC	–	–	–	–	E0P4T21	E0P5T26	–
Plug-In Adapters <sup>②</sup>	Field Fitted	–	✓	✓	✓	✓	✓	–
Rear Connecting Studs <sup>②</sup>	Field Fitted	–	✓	✓	✓	✓	✓	–
Handle Mechanism Field Fitted Only <sup>②</sup>	Flex Shaft	✓	✓	✓	✓	✓	✓	✓
	Type SM	–	–	–	✓	✓	–	–
	Rotary	✓	✓	✓	✓	✓	✓	–
	Type MC	–	–	–	✓	✓	–	–
	Slide Plate	–	–	–	✓	✓	✓	✓
	Direct	✓	✓	✓	✓	✓	✓	✓

**Test Kit**





Electronic Portable Test Kit (Digitrip 310 Only)	–	–	–	STK2	STK2	STK2	STK2
--	---	---	---	------	------	------	------

① K-, L-, N- and R-Frame breakers equipped with electronic trip units can operate reliably in ambient temperatures of 50°C.

② Contact Cutler-Hammer for catalogue numbers.

## Cutler-Hammer Frame Sizes G through R

### Selection Guide and Ordering Information

Accessory		Pole Location	Frame					
			G	E125 and J250	K	L	N	R
<b>Field Fit Kit Catalogue Numbers</b>								
Alarm Lockout 	Make/Break	Left	–	–	A1L3LPK	A1L4LPK	A1L5LPK	–
		Right	Factory Fit Only	ALM1M1BEPK	A1L3RPK	A1L4RPK	A1L5RPK	A1L6RPK
	2 Make/2 Break	Left	–	–	A2L3LPK	A2L4LPK	A2L5LPK	–
		Right	–	ALM2M2BEPK	A2L3RPK	A2L4RPK	A2L5RPK	A2L6RPK
Auxiliary Switch 	1A, 1B	Left	–	–	A1X3PK	A1X4PK	A1X5LPK	–
		Right	Factory Fit Only	AUX1A1BPK	A1X3PK	A1X4PK	A1X5RP	–
	2A, 2B	Left	–	–	A2X3PK	A2X4PK	A2X5LPK	–
		Right	Factory Fit Only	AUX2A2BPK	A2X3PK	A2X4PK	A2X5RPK	A2X6RPK
	3A, 3B	Left	–	–	A3X3LPK	A3X4PK	A3X5LPK	–
		Right	–	–	A3X3RPK	A3X4PK	A3X5RPK	–
Auxiliary Switch/ Alarm Lockout	Left	–	–	AAL3LPK	AA114LPK	AA115LPK	–	
	Right	–	AUXALRMEPK	AAL3RPK	AA114RPK	AA115RPK	–	
Shunt Trip – Standard <sup>①</sup> 	120 VAC	Left	Factory Fit Only	SNT120CPK	SNT3P11K	SNT4LP11K	SNT5LP11K	–
		Right	–	–	SNT3P11K	SNT4RP11K	–	SNT6P11K
	240 VAC	Left	Factory Fit Only	SNT480APK	SNT3P11K	SNT4LP11K	SNT5LP11K	–
		Right	–	–	SNT3P11K	SNT4RP11K	–	SNT6P11K
	24 VDC	Left	Factory Fit Only	SNT060CPK	SNT3P04K	SNT4LP03K	SNT5LP03K	–
		Right	–	–	SNT3P04K	SNT4RP03K	–	SNT6P03K
	48 VDC	Left	–	SNT060CPK	SNT3P06K	SNT4LP23K	SNT5LP23K	–
		Right	–	–	SNT3P06K	SNT4RP23K	–	SNT6P23K
Shunt Trip – Low Energy	Left	–	–	LST3LPK	LST4LPK	LST5LPK	–	
	Right	–	–	LST3RPK	LST4RPK	–	LST6RPK	
Undervoltage Release Mechanism <sup>①</sup> 	120 VAC	Left	Factory Fit Only	UVR120APK	UVH3LP08K	UVH4LP08K	UVH5LP08K	–
		Right	–	–	UVH3RP08K	UVH4RP08K	–	UVH6RP08K
	240 VAC	Left	Factory Fit Only	UVR480APK	UVH3LP11K	UVH4LP11K	UVH5LP11K	–
		Right	–	–	UVH3RP11K	UVH4RP11R	–	UVH6RP11K
	24 VDC	Left	–	UVR024CPK	UVH3LP21K	UVH4LP21K	UVH5LP21K	–
		Right	–	–	UVH3RP21K	UVH4RP21K	–	UVH6RP21K
	48 VDC	Left	–	UVR048DPK	UVH3LP23K	UVH4LP23K	UVH5LP23K	–
		Right	–	–	UVH3RP23K	UVH4RP23K	–	UVH6RP23K

① Shunt trip and undervoltage release can only be mounted in left pole of K- and L-Frame breakers equipped with electronic trip units.

Handle Mechanisms

Selection Guide and Ordering Information

Handle Mechanisms Overview

Handle Mechanisms are used to operate moulded case circuit breakers, moulded case switches and motor circuit protectors. They are available in three basic configurations — Flange Mounted, Through-the-Door and Direct (Close-Coupled) — providing safe, dependable operation and ease of installation.

Flange Mounted

- Flex Shaft

Through-the-Door

- Universal Rotary

Direct (Close-Coupled)

- Universal Direct
- Euro IEC
- G Direct

Handle mechanisms are typically used on enclosed circuit breakers, control panels and motor control centres in many different applications. Cutler-Hammer has a handle mechanism for virtually any need.

Flange Mounted Handle Mechanisms

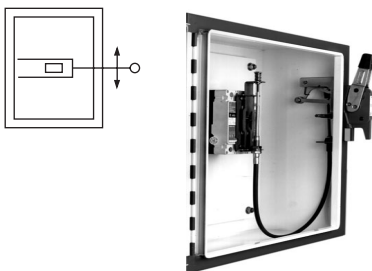

Flex Shaft™

Flange Mounted Handle Mechanisms mount on the flange of an enclosure door. The Flex Shaft™ is an extra heavy-duty mechanism that includes a flexible shaft in various lengths, 0.9 meters (3 feet) through 3 meters (10 feet) for use with various size enclosures.

The Flex Shaft Handle will accept up to three padlock shackles, each with a maximum diameter of 9.5 mm (3/8-inch). Can be used with NEMA 1, 3R and 12 fabricated enclosures. An optional handle is available for Flex Shaft that is suitable for use with NEMA 4 and 4X environments.

Flex Shaft comes preset from the factory, requiring only minor field adjustments on installation, which takes about 10 minutes — a significant time savings compared to installation of other types of flange handle mechanisms. The Flex Shaft mechanism also takes up less interior enclosure space than competitive

designs and the handle fits standard flange cutouts. Flex Shaft handle can be remotely mounted from breaker, where an operator can use it by “funneling” the cable through conduit.

Flex Shaft is UL Listed under File E64893 and meets CSA requirements.

Flex Shaft Ordering Information

Breaker Frame	Flexible Shaft Length Meters (Feet)							
	Catalogue Number							
	0.91m (3)	1.22m (4)	1.25m (5)	1.83m (6)	2.13m (7)	2.44m (8)	2.74m (9)	3.05m (10)
EF FJ	EHMFS03I JHMFS03I	EHMFS04I JHMFS04I	EHMFS05I JHMFS05I	EHMFS06I JHMFS06I	EHMFS07I JHMFS07I	EHMFS08I JHMFS08I	EHMFS09 JHMFS09	EHMFS10 JHMFS10
G K	F0S03CI F3S03CI	F0S04CI F3S04CI	F0S05CI F3S05CI	F0S06CI F3S06CI	F0S07CI F3S07CI	F0S08CI F3S08CI	F0S09C F3S09C	F0S10C F3S10C
L and MDL N R	N/A N/A N/A	F4S04CI F5S04CI F6S04CI	F4S05CI F5S05CI F6S05CI	F4S06CI F5S06CI F6S06CI	N/A N/A N/A	N/A N/A N/A	N/A N/A N/A	F4S10C F5S10C N/A

**Note:** Type 4/4X handle mechanisms are available. Add Suffix X before the I to complete Catalogue Number.

Add Suffix L to complete Catalogue Number for 152.4 mm (6-inch) handle.

Original narrow handle design (No C Suffix) is available. Remove C from Catalogue Number.

**Note:** When selecting the length of shaft, ensure minimum bending radius of 101.6 mm (4 inches) is maintained to operate properly.

The standard method of shipment includes the mechanism preset at the factory; however, minor field adjustments may be required.

Flex Shaft Accessories (E- through R-Frame)

Standard Door Hardware (Required Adapter Kit)

Latch	Panel Height mm (Inches)	Catalogue Number
2 point	Up to 762 (30)	DH1R
2 point	Up to 1016 (40)	DH2R
3 point	Over 1016 (40)	DH3R

Door Hardware Adapter Kit (Required on Standard Door Hardware)

Catalogue Number — AMTDHA
---------------------------

Flex Shaft Replacement Door Hardware Kits

Breaker Frame	Flexible Shaft	Catalogue Number
F J	5108A56G01 5108A56G02	LONR LH/RH
F J K	5108A56G15 5108A56G16 5108A56G17	LONR LH/RH LH/RH
F J K	5108A56G18 5108A56G19 5108A56G20	LONR LH/RH LH/RH

Door Hardware for Hoffman A – 25 Enclosure<sup>①</sup>

Latch	Panel Height mm (Inches)	Catalogue Number
2 point	Up to 1016 (40)	HDH-2R
3 point	Over 1016 (40)	HDH-3R

Flange Mounted Instruction Leaflets

Breaker Frame	Instruction Leaflet/FRED Number
<b>Flex Shaft</b>	
EF FJ G	29C265 29C518 TBD
F J K	15609 15605 15604
L and M N R	15606 15606 15606

<sup>①</sup> Kit consists of special door hardware and door interlock pin. Available for right hand flange mounting only.

## Handle Mechanisms

### Selection Guide and Ordering Information

#### Through-the-Door Handle Mechanisms

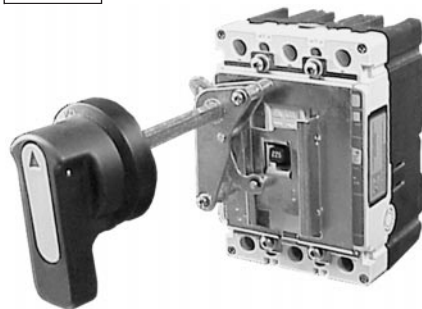
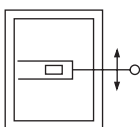

**Rotary**

The Cutler-Hammer Rotary is suitable for use with NEMA 1 and 12 enclosure types. All Rotary handle mechanisms include a handle "Lock Off," to prevent turning the breaker ON while in the OFF position. All Rotary handles indicate ON/OFF/ Tripped/Reset positions, however, Universal Rotary has the added feature of international markings for ON (I) and OFF (O). Cutler-Hammer Rotary handle is metal, Universal Rotary is made of moulded material. Cutler-Hammer Rotary handle is black and Universal Rotary is available in black or yellow/red.

#### Universal Rotary Ordering Information

Shaft Length in mm (Inches)	Handle Colour	Complete Catalogue Number <sup>①</sup>	Cutler-Hammer Rotary Complete Catalogue Number <sup>①</sup>	
			IEC IP65	IEC IP66
<b>EF-Frame</b>				
152.4 (6)	Black	EHMVD06B	—	—
304.8 (12)	Black	EHMVD12B	—	—
152.4 (6)	Red	EHMVD06R	—	—
304.8 (12)	Red	EHMVD12R	—	—
<b>FJ-Frame</b>				
152.4 (6)	Black	FJHMVD06B	—	—
304.8 (12)	Black	FJHMVD12B	—	—
152.4 (6)	Red	FJHMVD06R	—	—
304.8 (12)	Red	FJHMVD12R	—	—
<b>G-Frame</b>				
152.4 (6)	Black	GHMVD06B	—	—
304.8 (12)	Black	GHMVD12B	—	—
152.4 (6)	Red	GHMVD06R	—	—
304.8 (12)	Red	GHMVD12R	—	—
<b>F-Frame</b>				
152.4 (6)	Black	FHMVD06B	WHM1B06	WHM1B06X
304.8 (12)	Black	FHMVD12B	WHM1B12	WHM1B12X
152.4 (6)	Red	FHMVD06R	WHM1R06	WHM1R06X
304.8 (12)	Red	FHMVD12R	WHM1R12	WHM1R12X
<b>J-Frame</b>				
152.4 (6)	Black	JHMVD06B	WHM2B06	WHM2B06X
304.8 (12)	Black	JHMVD12B	WHM2B12	WHM2B12X
152.4 (6)	Red	JHMVD06R	WHM2R06	WHM2R06X
304.8 (12)	Red	JHMVD12R	WHM2R12	WHM2R12X
<b>K-Frame</b>				
152.4 (6)	Black	KHMVD06B	WHM3B06	WHM3B06X
304.8 (12)	Black	KHMVD12B	WHM3B12	WHM3B12X
152.4 (6)	Red	KHMVD06R	WHM3R06	WHM3R06X
304.8 (12)	Red	KHMVD12R	WHM3R12	WHM3R12X
<b>L- and MDL-Frames</b>				
152.4 (6)	Black	LHMVD06B	WHM4B06	WHM4B06X
304.8 (12)	Black	LHMVD12B	WHM4B12	WHM4B12X
152.4 (6)	Red	LHMVD06R	WHM4R06	WHM4R06X
304.8 (12)	Red	LHMVD12R	WHM4R12	WHM4R12X
<b>N-Frame</b>				
152.4 (6)	Black	HMVD15HB + HMCC5W	WHM5B06	WHM5B06X
304.8 (12)	Red	HMVD15HR + HMCC5W	WHM5R12	WHM5R12X
<b>R-Frame</b>				
152.4 (6)	Black	HMVD15HB + HMCC6W	WHM5B06	WHM5B06X
304.8 (12)	Red	HMVD15HR + HMCC6W	WHM5R12	WHM5R12X

#### Through-the-Door Instruction Leaflets/ FRED Number

Breaker Frame	Cutler-Hammer Rotary	Universal Rotary
EF	—	29C517
FJ	—	29C519
G	—	29C250
F	15594	29C250
J	15599	29C250
K	15600	29C250
L & MDL	15601	29C250
N	15602	—

<sup>①</sup> Complete catalogue number includes handle, mechanism, shaft and mounting hardware.

Handle Mechanisms

Selection Guide and Ordering Information

Direct (Close-Coupled) Handle Mechanisms



Universal Direct



Euro IEC Direct



G Direct

Direct (Close-Coupled) Handle Mechanisms mount directly to the circuit breaker. They are used in shallow enclosures where the standard variable depth Through-the-Door type mechanism is not practical or cannot be used. They are typically for applications where high volume, standardized enclosures are being fabricated.

The Universal Direct handle mechanism is designed exclusively for the new Cutler-Hammer E125 and J250 circuit breakers. It is available as standard with a door interlock to prevent opening the enclosure while the circuit breaker is in the ON position. It is also available without a door interlock.

The Euro IEC Direct handle mechanism can be used on F- through R-Frames.

G Direct is available with a black or yellow handle, and with or without a shroud. It is suitable for use with NEMA 1 enclosures. It is for use only with the G-Frame (GD, GC, GHC, GMCP).

An escutcheon ring and interlock clip are provided as standard. The standard design includes a lock-off feature.

The Universal Direct handle mechanism is UL 489 listed, IEC 60947-1/2 and meets CSA requirements. The Euro IEC Direct handle mechanism is IEC-240-1. G Direct is UL listed and meets CSA requirements.

Universal Direct Ordering Information

Frame	Universal Direct Domestic		Universal Direct International
	with Interlock (white)	without Interlock (white)	without Interlock (charcoal with global label)
Catalogue Number			
EF	EHMCCBI	EHMCCB	EHMCCR
FJ	JHMCCBI	JHMCCB	JHMCCR

Euro IEC Direct Ordering Information

Frame	Catalogue Number	
	Black Handle	Red Handle
K	HMCC3B	HMCC3R
L and M	HMCC4B	HMCC4R
N	HMCC5B	HMCC5R
R	HMCC6B	HMCC6R

G Direct Ordering Information<sup>①</sup>

Frame	Catalogue Number			
	Black Handle		Yellow Handle	
	with Shroud	without Shroud	with Shroud	without Shroud
GD	HRGCC1S	HRGCC10	HRGCC3S	HRGCC30
GC	HRGCC1S	HRGCC10	HRGCC3S	HRGCC30
GHC	HRGCC1S	HRGCC10	HRGCC3S	HRGCC30
GMCP	HRGMC1S	HRGMC10	HRGMC3S	HRGMC30

Direct (Close-Coupled) Instruction Leaflets

Frame	Instruction Leaflet/FRED Number		
	Universal Direct	Euro IEC Direct	G Direct
EF	29C255	—	—
FJ	29C256	—	—
G	—	—	15567
F	—	29C288A	—
J	—	29C288A	—
K	—	29C288A	—
L and MDL	—	29C289	—
N	—	29C290	—
R	—	29C291	—

<sup>①</sup> Suitable for use on 2- or 3-pole G-Frame.

**Selection Guide and Ordering Information**

**Remote Controlled Operating Mechanisms**

Cutler-Hammer Circuit Breakers (sizes 160 to 2000 amperes) can be equipped with motorized operating mechanisms for remote in-service closing and opening.

For normal remote opening, solenoid operating mechanisms F- and K-Frames are available for circuit breakers and motorized operating mechanisms for J to R (sizes 250 to 2500 amperes) solenoid operating mechanisms and motor operators are always supplied with a locking device for padlocks. This device can be used for electrical and mechanical blocking of the operating mechanism. All remote operating mechanisms are equipped with a manual actuator for local operation.

**Alarm Lockout**

The alarm switches operate when the circuit breaker is tripped by a short circuit or overcurrent, but also when it is tripped by a shunt trip or undervoltage release.

**Auxiliary Switches**

Auxiliary switches are used for signalling and control purposes. The various functions of the auxiliary switches (changeover) are shown in the top table to the right.

**Shunt Trips**

The shunt trip is used for remote tripping.

The coil of the shunt trip is rated only for short-time operation.

It is not permissible with the circuit breaker open to apply a continuous opening command to the shunt trip in order to prevent the breaker from closing.

This means that interlocking circuits with continuous commands may not be set up with shunt trips.

**Possible Equipment of E- and L-Frame Circuit Breakers with Auxiliary and Alarm Switches**

**3-Pole Circuit Breakers** (left and right poles):

□ / U<sub>c</sub> / DI	1 AUX
□ / U<sub>c</sub> / DI	2 AUX
□ / U<sub>c</sub> / DI	1 AS
□ / U<sub>c</sub> / DI	1 AS + 1 AUX
2 AS	1 AUX
1 AS	2 AUX
2 AS	2 AUX
—	4 AUX 4 AUX 4 AUX ●
—	U<sub>c</sub> / 2AS □ / 2AS □ / 2AS ●

**4-Pole Circuit Breakers** (left and right poles):

□ / U<sub>c</sub> / DI	—	1 AUX
□ / U<sub>c</sub> / DI	—	2 AUX
□ / U<sub>c</sub> / DI	—	1 AS
□ / U<sub>c</sub> / DI	—	1 AS 1 AUX
2 AS	—	1 AUX
1 AS	—	2 AUX
2 AS	—	2 AUX
—	—	4 AUX 4 AUX 4 AUX ●
—	—	U<sub>c</sub> / 2AS □ / 2AS □ / 2AS ●

**F-Frame for Motor Protection**

□ / U<sub>c</sub> / DI	—
1 AUX	—
2 AUX	—
1 AS	—
1 AS + 1 AUX	—
2 AS	—

□ / U<sub>c</sub> / DI = Shunt Trip or Undervoltage Release or DI Module (if Built-In)  
 AUX = Auxiliary Switch  
 AS = Alarm Switch  
 ● = For R-Frame Circuit Breakers Only

*E125 and J250 Auxiliary Switch or Alarm Switch in the Right Pole.  
 E125 and J250 Shunt Trip or UVR in the Left Pole.*

**Undervoltage Releases**

The circuit breaker cannot be closed until the undervoltage release is energized. If the release is not energized, the circuit breaker can only perform an idle switching operation.

Frequent idle switching actions should be avoided as they shorten the endurance of the circuit breaker.

**Contact making by the auxiliary and alarm switches as a function of the switching position of the circuit breaker**

Position of the Toggle Handle Drive (Equivalently Applicable for Rotary Drives)	Position of the Auxiliary Switch	Position of the Alarm Switch
OFF RESET		
ON		
Tripped		



## Time-Current Curves

### Tripping Characteristics

The operating values specified for the inverse time overcurrent releases (thermal overload releases, "a" releases) are mean values of the scatter bands of all setting ranges from the cold state and with uniform current loading of the conducting paths.

The tripping characteristics of the instantaneous (electromagnetic) short circuit releases ("n" releases) are based on the rated phase current  $I_n$  which in the case of circuit breakers with adjustable thermal overload releases is also the upper value of the setting range. With a lower setting current, a correspondingly higher multiple is obtained for the operating current of the "n" release.

Individual time-current curves K- and L-Frame Digitrip 310 Electronic Trip Curves are available upon request.

### Tripping time characteristics (Thermal Memory)

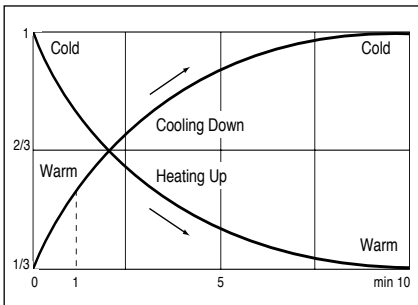

### Type GWF

Tripping characteristics of GWF circuit breakers for plant protection,  $I_{CU} = 25$  kA, "n" release fixed setting  $n = 500-1300$  for breaker 16-63A; 1300-1800 for breaker 70-100A

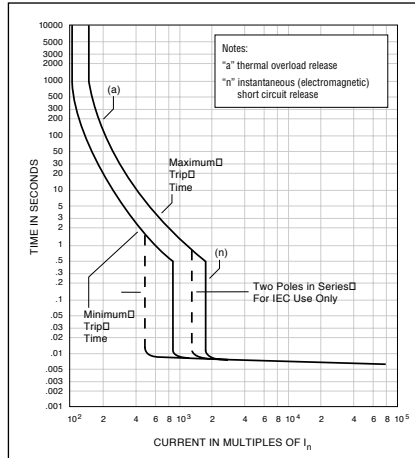

### Type E125

Tripping characteristics of E125 circuit breakers for plant protection,  $I_{CU} = 18/25/40/70$  kA, "n" release fixed setting  $n = 500-1300$  for breaker 16-63A; 1300-1800 for breaker 70-125A

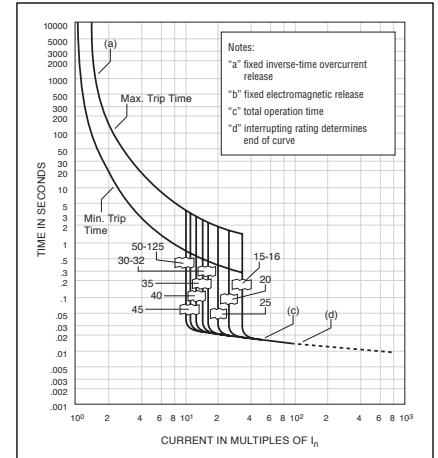

### Type J250

Tripping characteristics of J250 circuit breakers for plant protection,  $I_{CU} = 25/40/70$  kA, "n" release adjustable

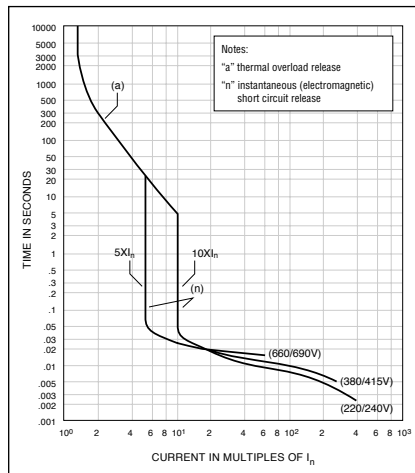

### Type KW

Tripping characteristics of KW circuit breakers for plant protection,  $I_{CU} = 45/70$  kA, "n" release adjustable

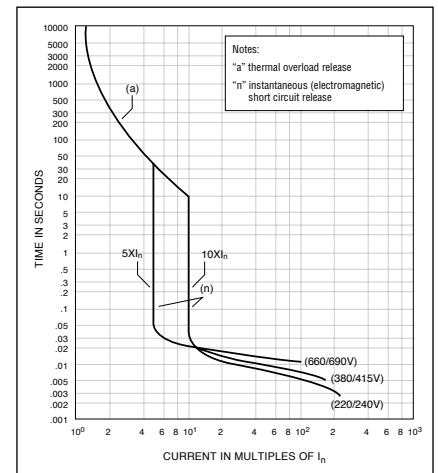

Cutler-Hammer Frame Sizes K through L

Time-Current Curves

Tripping Characteristics

The operating values specified for the inverse time overcurrent releases (thermal overload releases, "a" releases) are mean values of the scatter bands of all setting ranges from the cold state and with uniform current loading of the conducting paths.

The tripping characteristics of the instantaneous (electromagnetic) short circuit releases ("n" releases) are based on the rated phase current  $I_n$  which in the case of circuit breakers with adjustable thermal overload releases is also the upper value of the setting range. With a lower setting current, a correspondingly higher multiple is obtained for the operating current of the "n" release.

Type KW

Tripping characteristics of KW circuit breakers for plant protection,  $I_{CU} = 100$  kA, "n" release adjustable

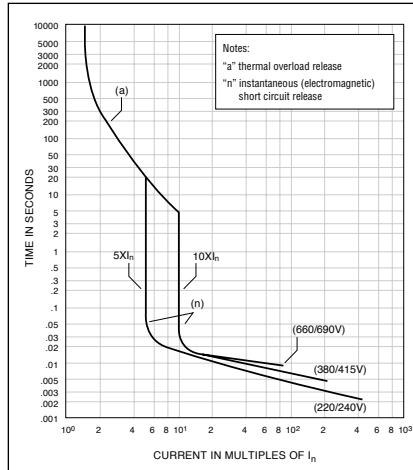

Type LW

Tripping characteristics of LW circuit breakers for plant protection,  $I_{CU} = 45/70$  kA, "n" release adjustable

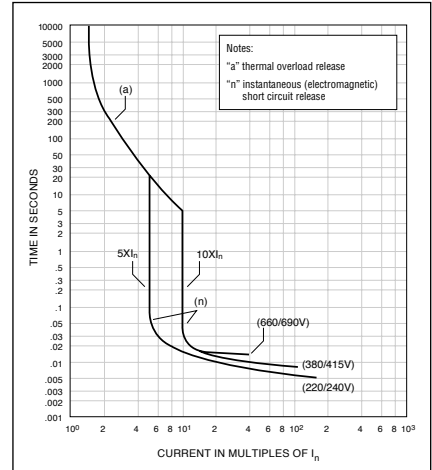

Type LW

Tripping characteristics of LW circuit breakers for plant protection,  $I_{CU} = 100$  kA, "n" release adjustable

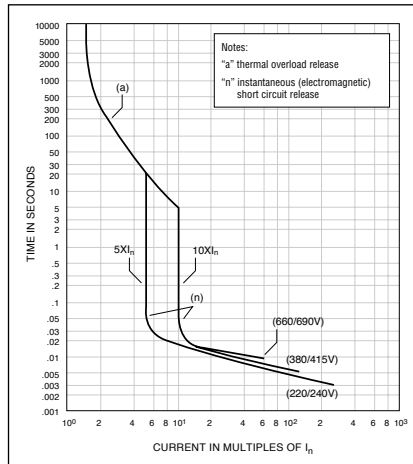

Time-Current Curves

Type NW

Tripping characteristics for NW circuit breakers,  $I_{cu}$  50/70/100 kA, with solid state overcurrent release

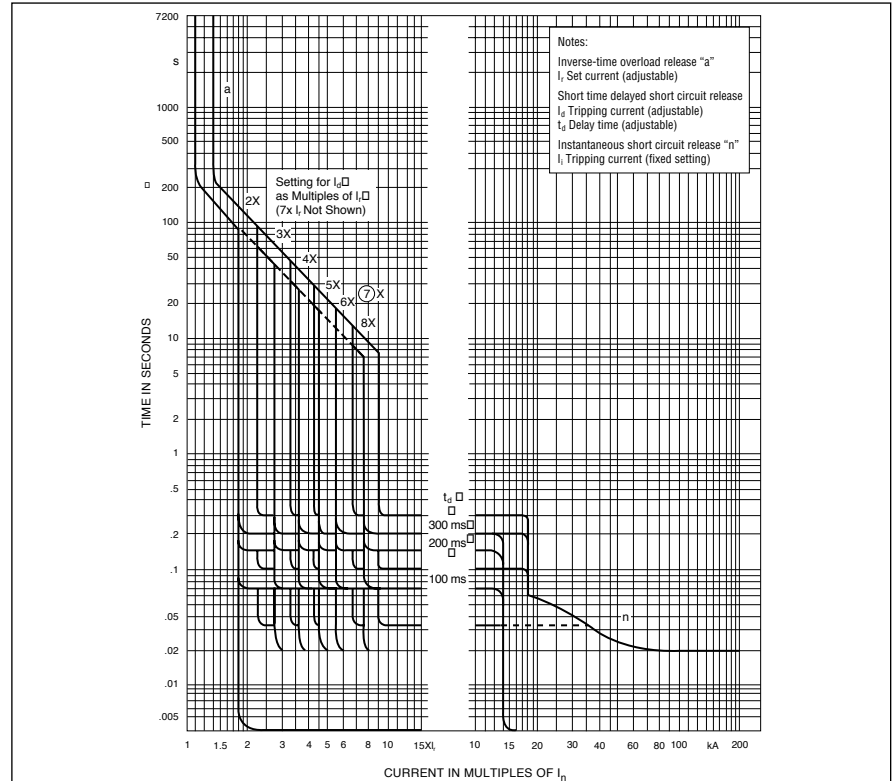

Working Temperature Range

The tolerance bands shown are applicable to an ambient temperature range of -5 to +60°C at the circuit breaker.

Type RW

Tripping characteristics for RW circuit breakers,  $I_{cu}$  70/100 kA, with solid state overcurrent release

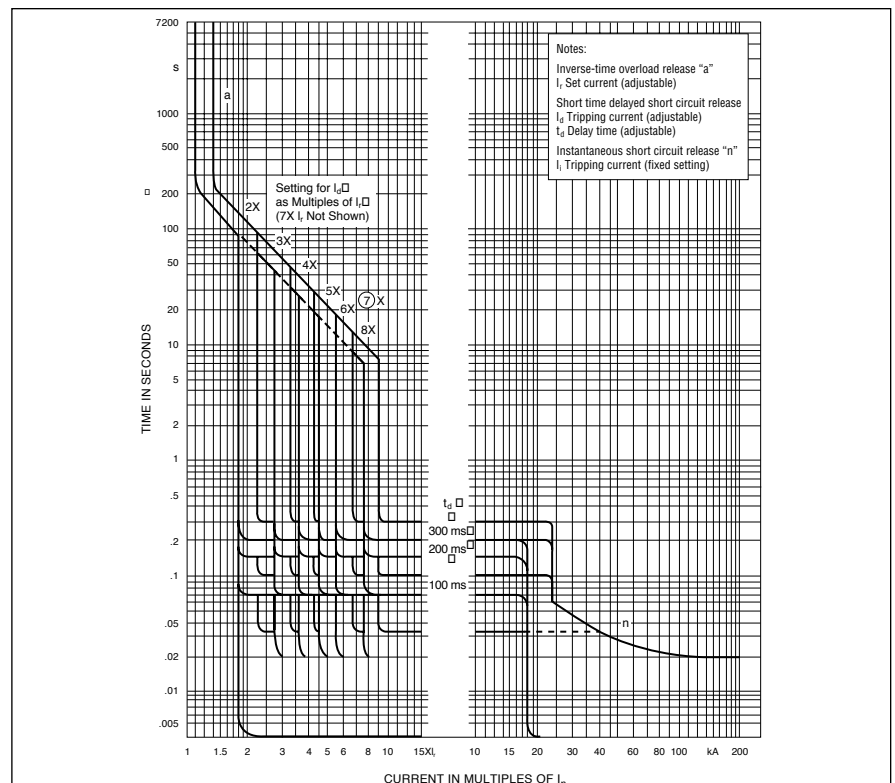

Working Temperature Range

The tolerance bands shown are applicable to an ambient temperature range of -5 to +60°C at the circuit breaker.

Cutler-Hammer Frame Sizes F through L

## Time-Current Curves

### Characteristics of the FWMP, KWMP, and LWMP Circuit Breakers for Motor Protection with Solid State Overcurrent Releases

The tripping times of the inverse-time delayed overcurrent releases are only valid for the not preloaded (cold) state. At operating temperature (after load with rated current), the tripping times are reduced to approximately 33%. After an overcurrent trip, the tripping times are reduced according to the tripping time characteristics (see figure below) so that cooling down for some minutes is required before restarting the motor. During the first minute after tripping, reclosing of the circuit breaker is blocked.

### Type FWMP, KWMP, and LWMP

Tripping characteristics for FWMP, KWMP, and LWMP circuit breakers for motor protection with solid state overcurrent releases

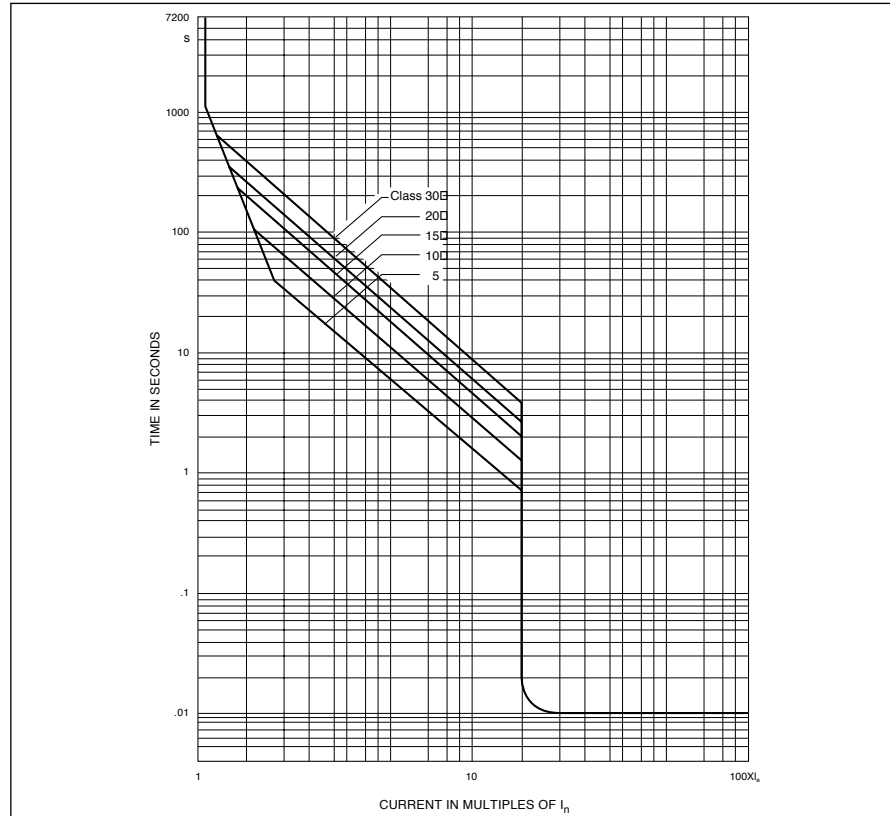

Current Limiting Curves

Current Limiting Characteristics and Maximum I<sup>2</sup>t Values

Type E/LW

Current limiting characteristics for E to LW, 50/60 Hz 380/415 VAC

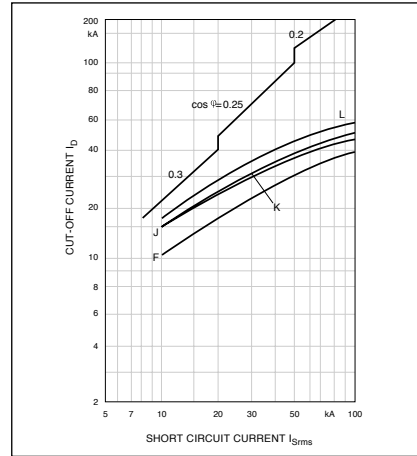

Type E/LW

Current limiting characteristics for E to LW, 50/60 Hz 660/690 VAC

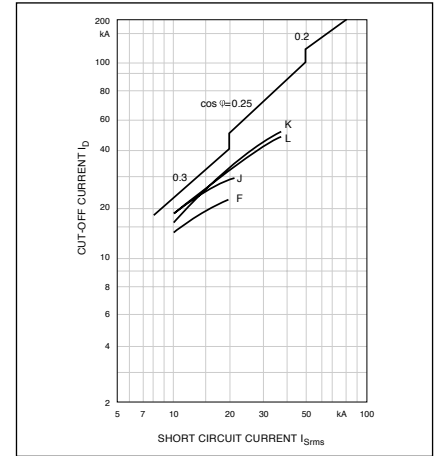

Type NW/RW

Current limiting characteristics for NW to RW, 50/60 Hz 380/415 VAC

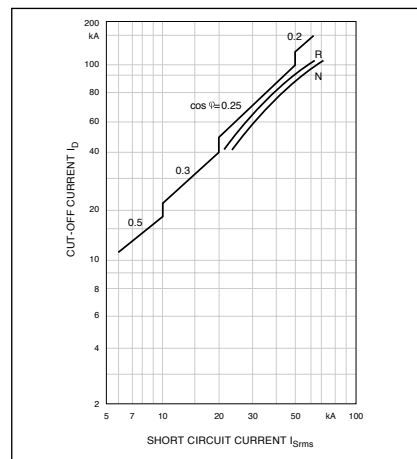

Type FW/LW

Maximum I<sup>2</sup>t values for FW to LW, 50/60 Hz 380/415 VAC

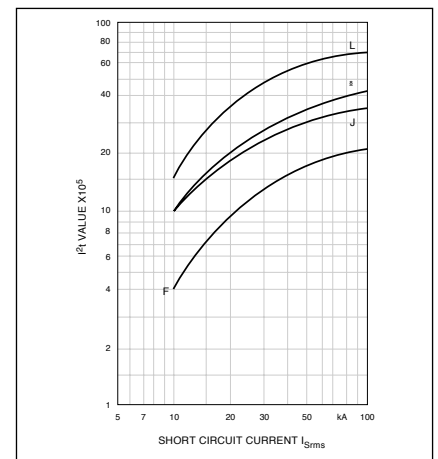

Type FW/LW

Maximum I<sup>2</sup>t values for FW to LW, 50/60 Hz 660/695 VAC

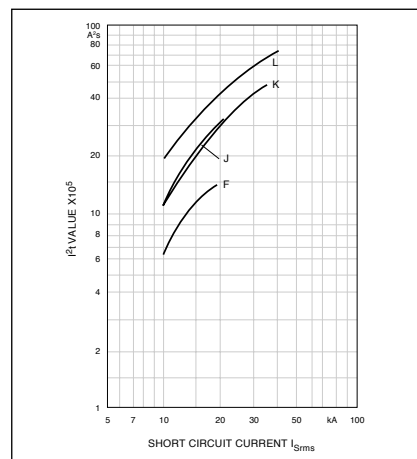

Type NW/RW

Maximum I<sup>2</sup>t values for NW to RW

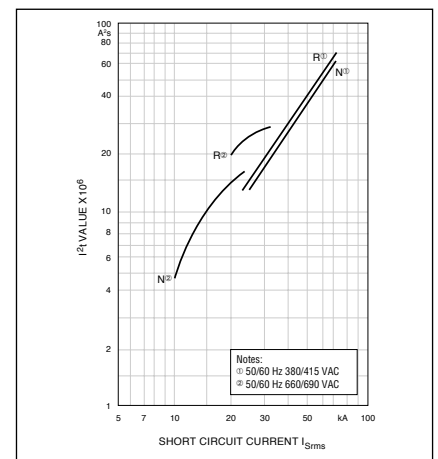

**Cutler-Hammer Frame Sizes G through K**

**Dimensions, mm (inches)**

**G-Frame**

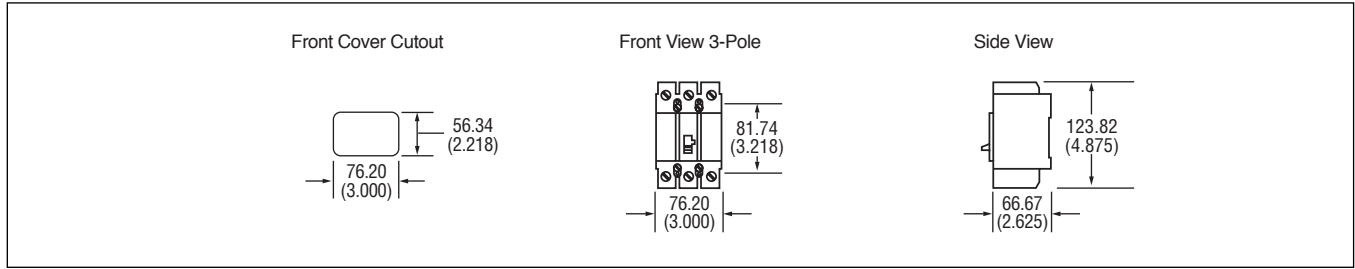

**E125-Frame**

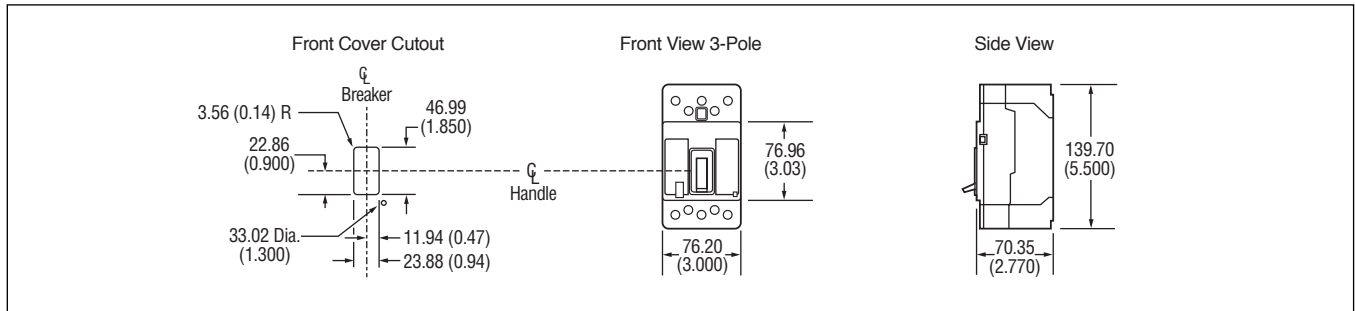

**J250-Frame**

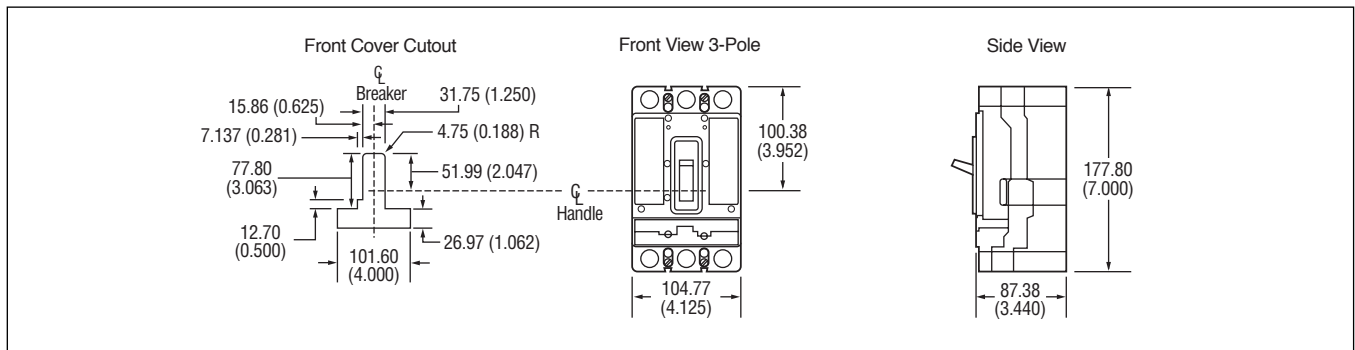

**K-Frame**

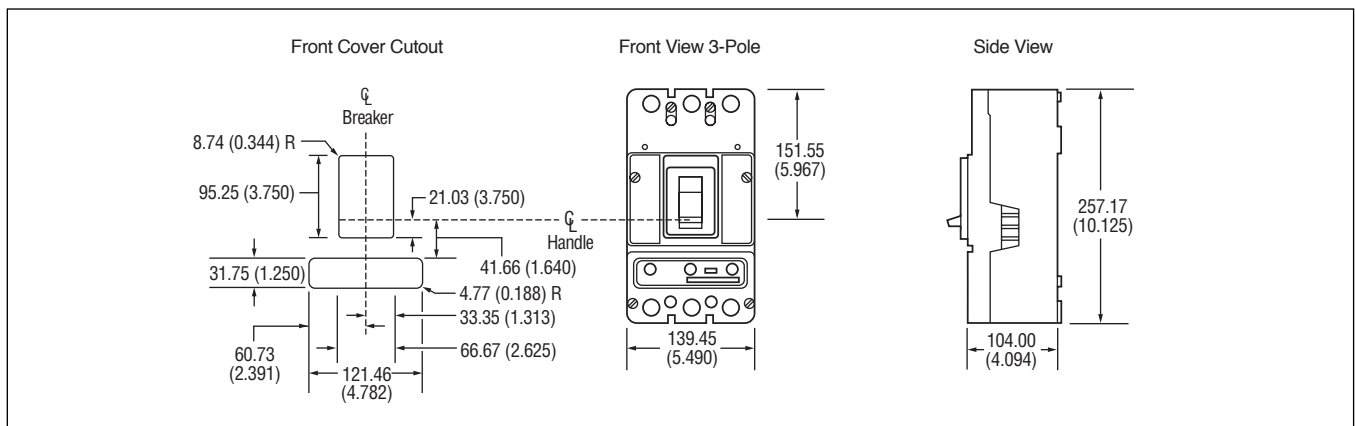

*Dimensions in parentheses in inches.*

Cutler-Hammer Frame Sizes L through R

Dimensions, mm (inches)

L-Frame 630 (Bus extensions not included)  
L-Frame 800

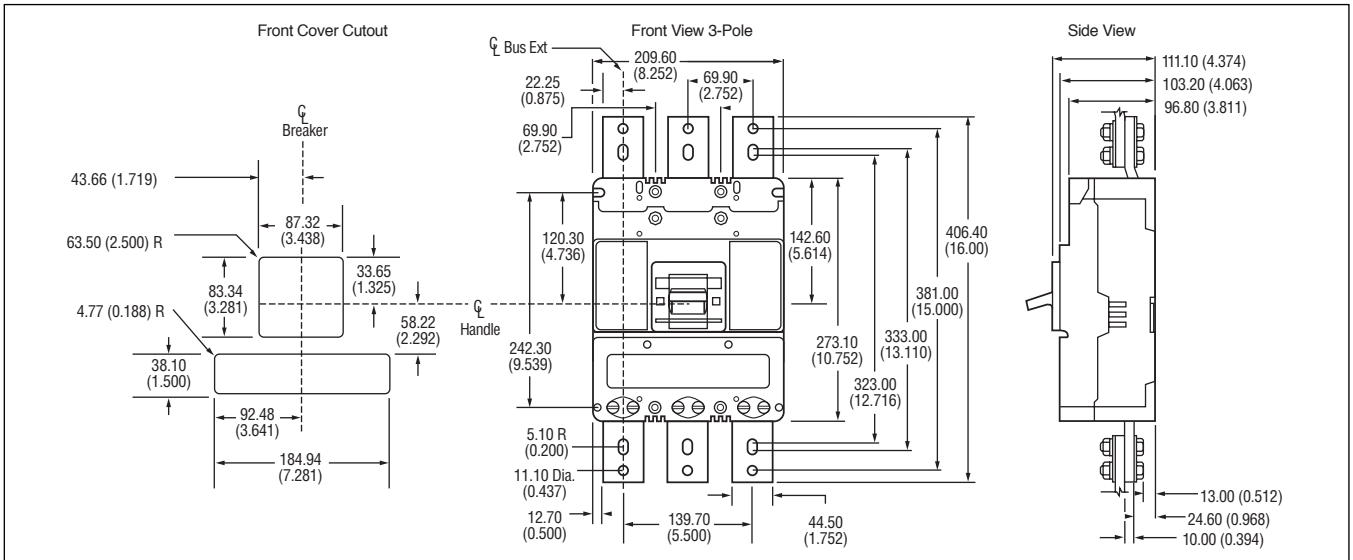

N-Frame

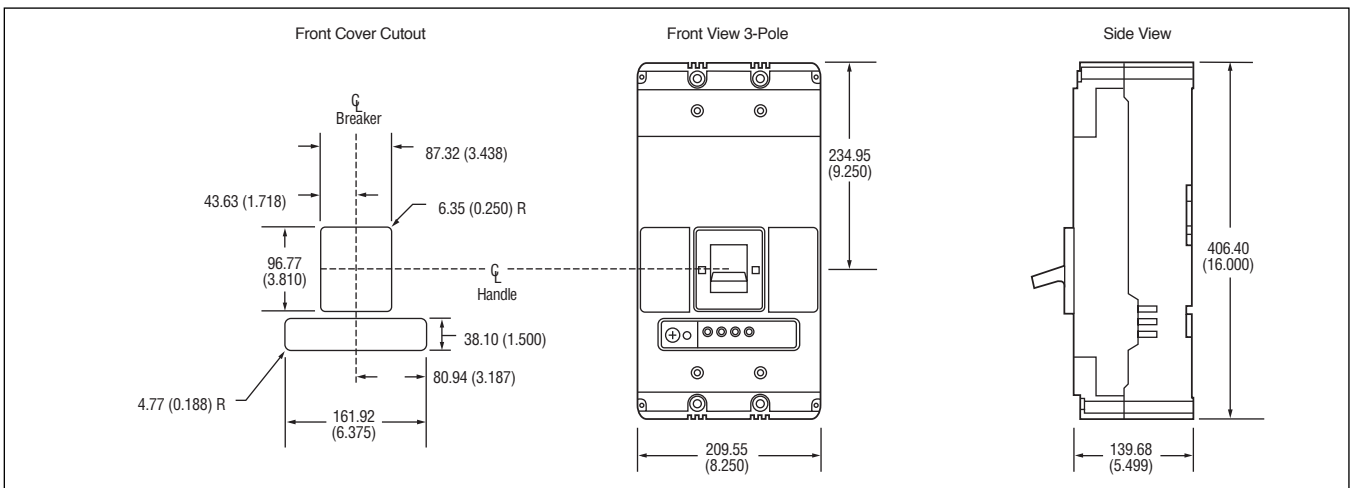

R-Frame

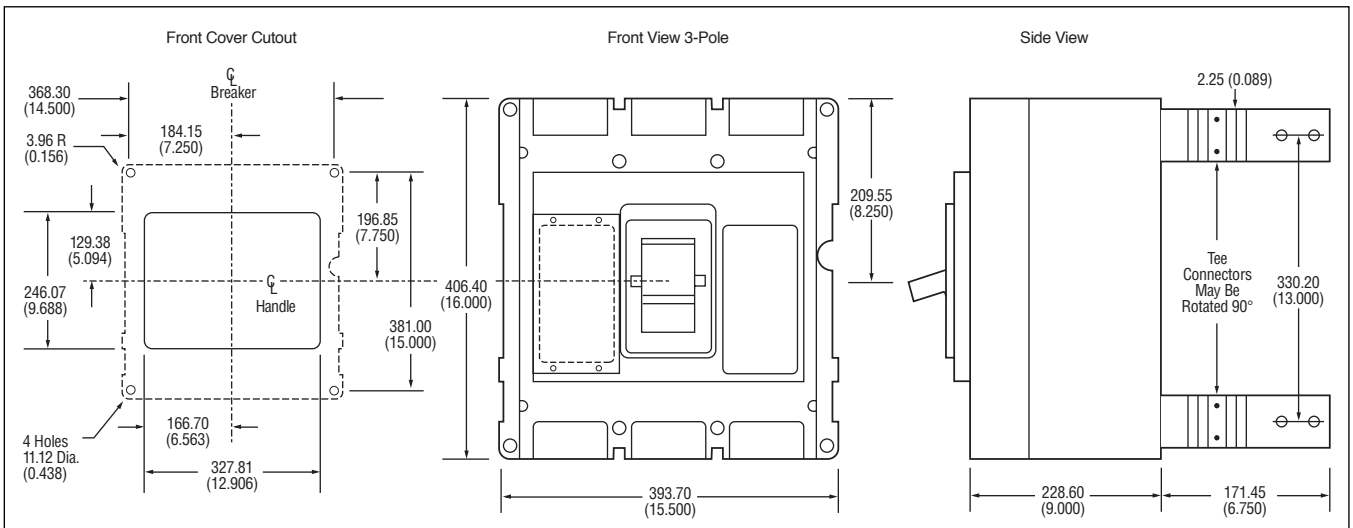

Dimensions in parentheses in inches.



## Cutler-Hammer Sales Offices

### Sales Offices

Country	Address	Office Phone	Office Fax
<b>Argentina</b>			
	Cutler-Hammer, Inc. Calle Reconquista 656, Piso 13 (1003) Capital Federal – Buenos Aires, Argentina	(54-11) 4315-4066	(54-11) 4314-8946
<b>Australia</b>			
	Cutler Hammer Pty Ltd P.O. Box 85 Rosebery, NSW 1445, Australia	(61-2) 9693-9333	(61-2) 9693-1258
<b>Brazil</b>			
	Cutler-Hammer, Inc. Eletromar Plant Estrada Velha da PaPavuna, 257 21058-900 Rio de Janeiro-RJ-Brazil	(55-21) 865-3912	(55-21) 290-1645
<b>Canada</b>			
	Cutler-Hammer Canada 3228 South Service Road, Box 5040 Station A Burlington, Ontario L7R 3Y8	(905) 333-6442	(905) 631-4248
<b>Chile</b>			
	Cutler-Hammer, Inc. Neveria 4631, Office 210 /203 Las Condes CP 6761670 Santiago, Chile	(56-2) 207-1695	(56-2) 207-1699
<b>China</b>			
	Cutler-Hammer China 193 Su Hong Xi Road, Suzhou Industrial Park Suzhou, 215021, PRC	(86-512) 716-3728	(86-512) 716-9535
<b>Costa Rica</b>			
	Cutler-Hammer, Inc. Industrial Control & Power Distribution Operations-Worldwide Power Distribution Division Apartado Postal 10156 1000 San Jose, Costa Rica	(506) 235-6022	(506) 235-9156
<b>Egypt</b>			
	Cutler-Hammer, Inc. 9, Shehab Street- #11, Mohandessin 12411 Cairo, Egypt	(20-2) 338-6170	(20-2) 338-2025
<b>El Salvador</b>			
	Cutler-Hammer, Inc. Centro Comercial Villas Españolas, Local C-1 San Salvador, El Salvador	(503) 263-6557	(503) 264-4144
<b>France</b>			
	Cutler-Hammer 11 Rue Chataigneraie 73000 Barberaz, France	(33-4) 79604763	(33-4) 79604766
<b>Germany</b>			
	Eaton GmbH Oranienpassage, 1 57258 Freudenberg, Germany	(49-2734) 4663-0	(49-2734) 4760-5
<b>Guatemala</b>			
	Cutler-Hammer, Inc. Avenida Reforma 7-62 zona 9 Edificio Aristos Reforma, Oficina N°704 Ciudad de Guatemala, Guatemala	(502) 362-9168	(502) 385-0343
<b>Honduras</b>			
	Cutler-Hammer, Inc. Honduras Edificio Miramontes Plaza Apart. Hoteles Continental S.A. Segundo nivel, local N°10 Tegucigalpa, Honduras	(504) 235-7554	N/A
<b>Indonesia</b>			
	Cutler-Hammer Suite 503A Sentra Mulia JI HR Rasuna Said Kav X-6 No.8 Jakarta 12940, Indonesia	(62-21) 522-2020	(62-21) 522-2110

Country	Address	Office Phone	Office Fax
<b>Jordan</b>			
	Cutler-Hammer, Inc. P.O. Box 510449 Amman 11151, Jordan	(962-6) 474-0660	(962-6) 962-660
<b>Korea</b>			
	Eaton Limited-Korea 7th Floor, Woo Duk Building 832-2, Yeoksam-dong, Kangnam-ku Seoul, 135-750, Korea	(82-2) 557-0313	(82-2) 557-1634
<b>Malaysia</b>			
	Eaton Corporation Regional Office c/o Alpha Executive Business Center 1005 Blk B Level 10 Phileo Tamansara 9 Jin 16/11 Off Jin Tamansara 46350 Petaling Jaya, Selangor, Malaysia	(60-3) 737-2970	(60-3) 737-2960
<b>Mexico</b>			
	Cutler Hammer, Inc. Rojo Gomez 1300 Col. Sn.Miguel Iztapalapa Mexico City DF 09360 Mexico	(52-5) 804-8230	(52-5) 804-8232
<b>New Zealand</b>			
	Cutler Hammer P.O. Box 12648 Penrose, Auckland, New Zealand	(82-2) 557-0313	(82-2) 557-1634
<b>Nicaragua</b>			
	Cutler-Hammer, Inc. Edificio Ofiplaza El Retiro Modulo N°5-1.1 De los semaforos de la antrada al antiguo, Nejapa Country Club o CAS 200 m al sur Managua, Nicaragua	(505) 270-0920	(505) 270-0900
<b>Panama</b>			
	Cutler-Hammer, Inc. Avenida Ricardo J. Alfaro Edificio Plaza Edison, Segundo Nivel, Oficina N°7 Ciudad de Panama, Panama	(507) 321-0288 / 0289	(507) 321-0290
<b>Saudi Arabia</b>			
	Cutler-Hammer, Inc. P.O. Box 19651, Riyadh 11445 Kingdom of Saudi Arabia	(966-1) 460-2275	(966-1) 460-2991
<b>Singapore</b>			
	Cutler-Hammer Pte Ltd 3 Tai Seng Drive #03-01 Marconi Building Singapore 535216	(65) 382-7330	(65) 382-7262
<b>Thailand</b>			
	Cutler-Hammer (C-H 1254) Eaton Technologies Limited, 91/1 Chailyo Building, 5th Floor, Rama 1X Road, Huaykwang Bangkok 10320 Thailand	(66-2) 643-9504-8	(66-2) 643-9509
<b>United Kingdom</b>			
	Cutler-Hammer Carina, Sunrise Parkway Linford Wood Milton Keynes MK146NR	(44-0-1908) 541600	(44-0-1908) 660527
<b>United States</b>			
	Cutler-Hammer, Inc. 1000 Cherrington Way Pittsburgh, PA 15108	(412) 893-3300	N/A
<b>Venezuela</b>			
	Cutler-Hammer, Inc. Avda. Libertador, El Rosal, Edificio Lex, Piso 1 Caracas 1060, Venezuela	(58-2) 953-1697	(58-2) 953-2585 / 2841
<b>United Arab Emirates</b>			
	Cutler-Hammer Inc. P.O. Box 9398, Dubai World Trade Centre – Level 10 Dubai, United Arab Emirates	(971-4) 331-3938	(971-4) 332-9239

# Typical Specifications for Cutler-Hammer Moulded Case Circuit Breakers

The circuit breakers shall meet or exceed all standards as defined in IEC 60947-2. Electrical circuits shall be protected by Cutler-Hammer World Moulded Case Circuit Breakers as manufactured by Cutler-Hammer.

Each pole of the one-, two-, and three-pole circuit breakers shall provide complete circuit overcurrent protection by having inverse time and instantaneous tripping characteristics and, where applicable, be current limiting.

The circuit breaker shall be available in interrupting families that provide 35-65-100 kA at 380-415 volts AC.

The circuit breakers shall be operated by a toggle-type handle and have a quick-make, quick-break, over-centre switching mechanism that is mechanically trip-free from the handle so that the contacts cannot be closed against short circuit currents. Tripping due to overload or short circuits shall be clearly indicated by the position of the handle. The ON and OFF positions shall be clearly marked on the cover of the circuit breaker along with the international symbols I for ON and O for OFF on the handle, providing positive indication of the circuit breaker contact position. Additionally, a colour-coded indication of the circuit breaker contact position shall be provided: red for ON, green for OFF, and white for TRIPPED. An easily accessible Push-To-Trip button for mechanically exercising the trip unit shall be provided on the cover of each circuit breaker. All poles of a multi-pole circuit breaker shall be so constructed as to ensure simultaneous open, close, and trip operations.

Circuit breakers shall be completely enclosed in a high strength glass-polyester case.

Noninterchangeable trip circuit breakers shall be factory sealed; interchangeable trip circuit breakers shall have the trip unit sealed to prevent tampering. Ampere ratings shall be clearly visible from the front of the circuit breaker. Contacts shall be nonwelding silver alloy. Arc extinction shall be accomplished by means of DE-ION<sup>®</sup> arc extinguishers consisting of metal grids mounted in an insulating support.

The minimum interrupting ratings of the circuit breakers shall be at least equal to the available short circuit current at the line terminals.

The circuit breakers can be applied in series rated applications and subject to test data verification.

Circuit breakers in frame sizes 125 amperes through 250 amperes shall be equipped with thermal-magnetic trip units. Circuit breakers 400 amperes through 2500 ampere frame sizes shall be equipped with electronic trip units that are insensitive to changes in ambient temperature within the normal operating temperature range of the circuit breaker. The 400 ampere and 630 ampere frame sizes shall be designed to accept either thermal-magnetic or electronic interchangeable trip units.

Electronic trip units shall be rms sensing type and have unpowered thermal memory.

Circuit breaker ratings and modifications shall be indicated on the drawings.

Circuit breakers shall be of the inverse time and instantaneous trip type as provided by thermal-magnetic or electronic trip elements with either standard interrupting, high interrupting, or current limiting characteristics as required.

Moulded case circuit interrupters (motor circuit protectors) shall be of the instantaneous (magnetic) only type, providing instantaneous short circuit protection by means of a front adjustable trip unit.

Moulded case switches shall be of the same construction as the related listed circuit breaker and equipped with a factory sealed, nonadjustable, high instantaneous only short circuit protection.

Moulded case switches shall have no overload or low level fault protection provided and shall be marked with a maximum withstand rating denoting the type and level of upstream protection required. Moulded case switches shall be listed per IEC 60947-2.

Internally mounted accessories including alarm (signal)/lockout switches, auxiliary switches, shunt trips, and undervoltage released mechanisms shall be of the plug-in type and shall be listed for field fitting in circuit breakers which are not factory sealed.

Electrical operators for circuit breakers of the 400 ampere frame size and below shall be of the solenoid type with maximum five-cycle closing characteristics. Electrical operators for circuit breaker frame sizes 630 amperes through 2500 amperes shall be of the motor driven type. All electrical operators shall be cover mounted. All electrical operators shall be listed for field installation per IEC 60947-2.

Electrical characteristics of accessories shall be as indicated on the drawings.

Circuit breakers in the 125 amperes rating shall be supplied in one-, two-, three-, and four-pole models, as specified on the drawings. Circuit breakers in ratings of 225 amperes through 1250 amperes shall be supplied in two-, three-, or four-pole models. The 2500 ampere circuit breaker is available in three- and four-pole models as specified on the drawings.

Accessory wiring shall be brought out through the side or rear of the circuit breaker, or be connected to a terminal block mounted on the side of the circuit breaker, as specified. The ability to route accessory wiring to the opposite side of the circuit breaker through a trough in the base shall be provided.

Circuit breakers shall be provided with uniformly designed nameplates to clearly indicate the type, rating, listing/recognition/certification marks, accessory details, and other information defined in IEC 60947-2.