

CONNECTORS

Mechanical Connectors

Aluminum, Dual Rated, Lay-In GLA Series

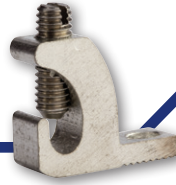

SPECIFICATIONS

- UL Listed/cULus Listed for Wire Connector.
- UL486A/B Listed. AL9CU.
- CSA 701642 (GLA-250).
- **Temperature Rating:** 90 °C.
- **Voltage:** 600V (2000V max. per UL486B).
- *UL467 Listed Grounding & Bonding Equipment.

FEATURES

- Lay-in connectors offer the ultimate in flexibility.
- Excellent for grounding and continuous loop applications.
- Made of 6061T-6 aluminum alloy.
- Electro-tin plated for low contact resistance.
- For use with copper or aluminum conductors.
- Stainless Steel Screw (GLA-4 only).

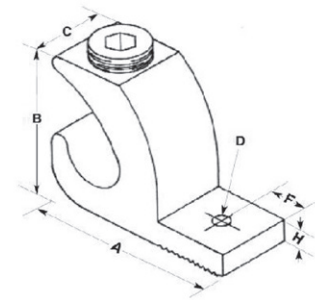
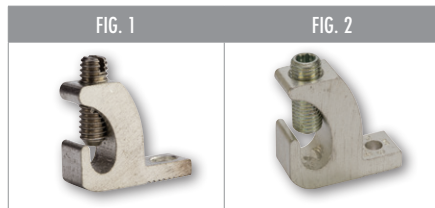

CAT. NO.	CERTIFICATION	FIG. NO.	WIRE RANGE	MAX TORQUE VALUE (IN./LBS.)	HEX WRENCH SIZE (IN.)	MTG. BOLT SIZE	LENGTH (A)	HEIGHT (B)	WIDTH (C)	MTG. HOLE DIA. (D)	TANG LENGTH (F)	TANG THICKNESS (H)	STD. CTN. QTY.	
GLA-4	cULus	1	4-14 AWG	45	Slotted	⬢	0.187	1.070	0.750	0.380	0.218	0.190	0.150	100
GLA-0	cULus	1	1/0-8 AWG	120	Slotted	⬢	0.250	1.500	1.100	0.600	0.272	0.300	0.220	40
GLA-000	cULus	1	3/0-6 AWG	250	1/4	⬢	0.375	2.000	1.500	0.800	0.330	0.400	0.300	20
GLA-250	UL Recognized CSA	2	250 MCM-6 AWG	330	1/4	⬢	0.375	2.200	1.700	0.800	0.330	0.400	0.300	20

CONNECTORS

Mechanical Connectors

Aluminum, Dual Rated, Lay-In GLA Series

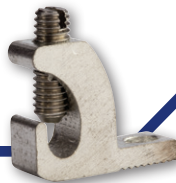

SPECIFICATIONS

- UL Listed/cULus Listed for Wire Connector.
- UL486A/B Listed. AL9CU.
- CSA 701642 (GLA-250).
- **Temperature Rating:** 90 °C.
- **Voltage:** 600V (2000V max. per UL486B).
- *UL467 Listed Grounding & Bonding Equipment.

FEATURES

- Lay-in connectors offer the ultimate in flexibility.
- Excellent for grounding and continuous loop applications.
- Made of 6061T-6 aluminum alloy.
- Electro-tin plated for low contact resistance.
- For use with copper or aluminum conductors.
- Stainless Steel Screw (GLA-4 only).

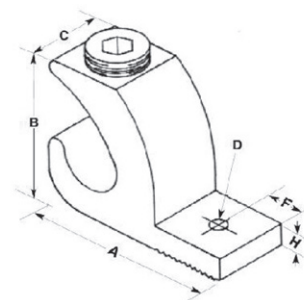
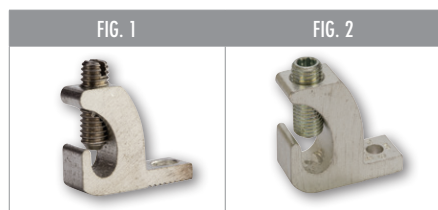

CAT. NO.	CERTIFICATION	FIG. NO.	WIRE RANGE	MAX TORQUE VALUE (IN./LBS.)	HEX WRENCH SIZE (IN.)	MTG. BOLT SIZE	LENGTH (A)	HEIGHT (B)	WIDTH (C)	MTG. HOLE DIA. (D)	TANG LENGTH (F)	TANG THICKNESS (H)	STD. CTN. QTY.	
GLA-4	cULus	1	4-14 AWG	45	Slotted	⬡	0.187	1.070	0.750	0.380	0.218	0.190	0.150	100
GLA-0	cULus	1	1/0-8 AWG	120	Slotted	⬡	0.250	1.500	1.100	0.600	0.272	0.300	0.220	40
GLA-000	cULus	1	3/0-6 AWG	250	1/4	⬡	0.375	2.000	1.500	0.800	0.330	0.400	0.300	20
GLA-250	UL Recognized CSA	2	250 MCM-6 AWG	330	1/4	⬡	0.375	2.200	1.700	0.800	0.330	0.400	0.300	20

CONNECTORS