

SINGLE ZONE SWITCHING AND DIMMING CLOSED LOOP DIGITAL PHOTOSENSOR

LMLS-400

Daylight responsive on/off, bi-level, tri-level or dimming control for one lighting zone

Extended tube model accommodates thicker ceiling materials

100 degree spatial response for optimal detection of ambient light level



Automatic calibration and configuration; optional hold off setting to maximize energy savings

Photodiode corrected to match the photopic response of the human eye

Can be calibrated in any daylight condition



DESCRIPTION

The LMLS-400 is a closed loop photosensor that measures the ambient light level in order to automatically switch or dim one zone of lighting. It is part of a Digital Lighting Management (DLM) system and sends light level signals to control loads connected to DLM on/off or dimming room controllers. The LMLS-400 has a photodiode with an extended range of 1-1,553 footcandles (fc), and photopic correction to mimic the human eye, for precise measurement of visible light.

OPERATION

The LMLS-400 operates on Class 2 power supplied to a DLM local network by one or more DLM room controllers. When there is one LMLS-400, Plug n' Go™ assigns load 1 to daylighting control. An LMCT-100-2 is used to assign additional loads, and assign loads to multiple photosensors. Following an automatic setup process, the LMLS-400 monitors the ambient light in the controlled space and works with the room controller(s) to maintain the design light level. Wattstopper's exclusive control algorithm uses on/off or dimming setpoints and other control parameters to establish the correct light levels throughout the day regardless of changing daylight contribution.

FEATURES

- Digital Lighting Management components plug together on a free-topology Cat 5e DLM local network
- Test mode override of programmed time delay allows easy verification of selected settings
- Load status verification allows confirmation and testing of controlled load
- Mounting options for hard ceilings, dropped ceilings and suspended lighting fixtures
- Infrared (IR) transceiver for wireless configuration and control
Compatible with DLM wall switches for manual override, if desired
- LED status indicators
- Complies with California Title 24, Section 119 requirements
- The product meets the materials restrictions of RoHS
- BAA/TAA-compliant models available

AUTOMATIC SETUP

After installation, the LMLS-400 measures the daylight and electric light levels in order to automatically calibrate itself and establish setpoints. This process may be initiated from the photosensor or a handheld LMCT-100-2 wireless configuration tool. The LMCT-100-2 may also be used to adjust setpoints and other parameters including hold off functionality. Adjustable switching parameters include on and off setpoints and time delays. The off setpoint can be adjusted to a value of 25, 50 (default), 75, or 100 percent above the on setpoint. Adjustable dimming parameters include day and night setpoints, ramp up and down rates, and a cut-off time delay. Electric lights can be turned off (default) or dimmed to a user-selectable minimum level when daylight contribution is abundant.

APPLICATIONS

The LMLS-400 photosensor is recommended for use in private offices, cafeterias, classrooms, atriums, lobbies and perimeter spaces with daylight contribution. It is designed to sense both daylight and electric light, and is typically ceiling mounted for sidelighting applications. The LMLS-400 can be used for on/off switching, bi-level or tri-level step switching or step dimming, or continuous dimming.

PROJECT

LOCATION/
TYPE

SPECIFICATIONS

- Input voltage: 24VDC from DLM local network
- Current consumption: 7mA
- DLM local network connection: 1 RJ45 port
- Digital multi-band photodiode with extended range: 1-1,553 fc (10-16,716 lux)
- Spatial response: 100°
- LED status and configuration indicators
- Infrared (IR) transceiver
- Weight: 1.4 oz (40 g)
- Operating conditions: for indoor use only; 32-131°F (0-55°C); less than 90% RH, non-condensing
- UL and cUL listed
- FCC part 15 compliant
- Five year warranty

DIMENSIONS & MOUNTING

Product Dimensions

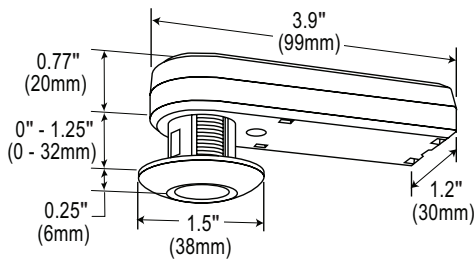

Placement for Sidelight Applications

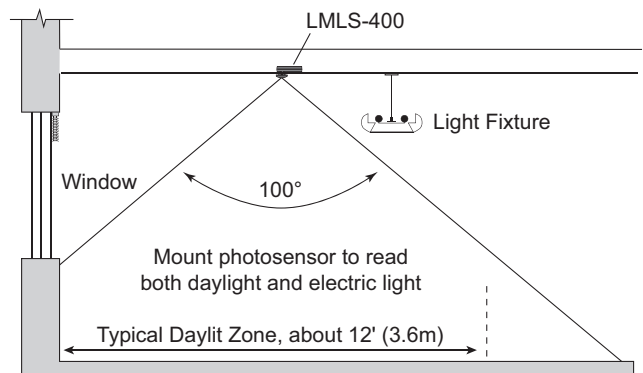

Mounting

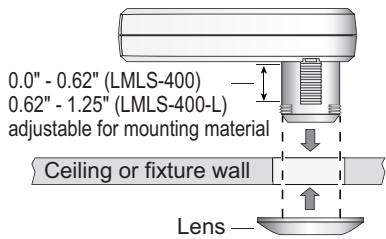

Mount in Ceiling

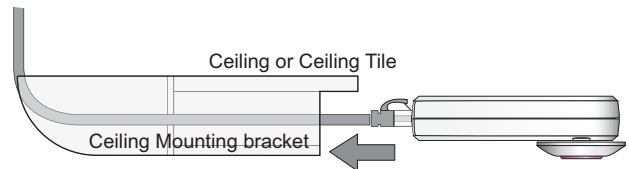

Mount to Ceiling with LMLS-MB2 bracket

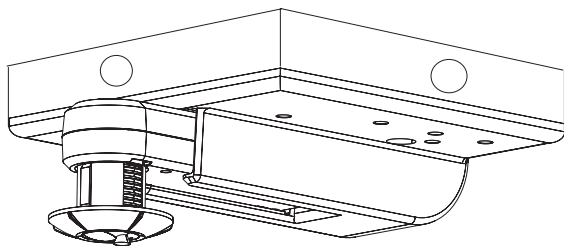

Mount to J-box with LMLS-MB1 bracket

PHOTODIODE RESPONSE

Spectral Response

The photodiode detects just visible light, which ensures accurate lighting control.

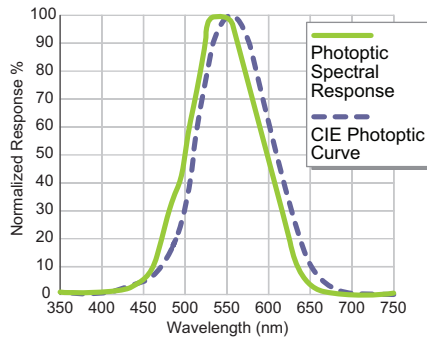

Spatial Response

Focused spatial response allows accurate detection of ambient light without interference from direct daylight or electric light sources.

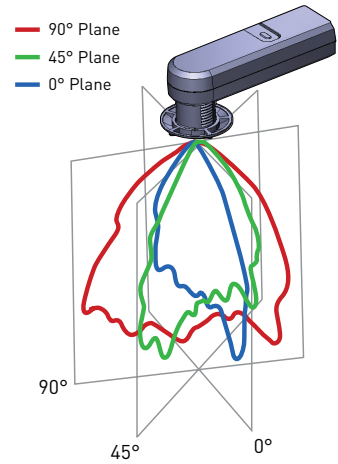

CONNECTING

Sample Connection Diagram for On/Off Switching Application

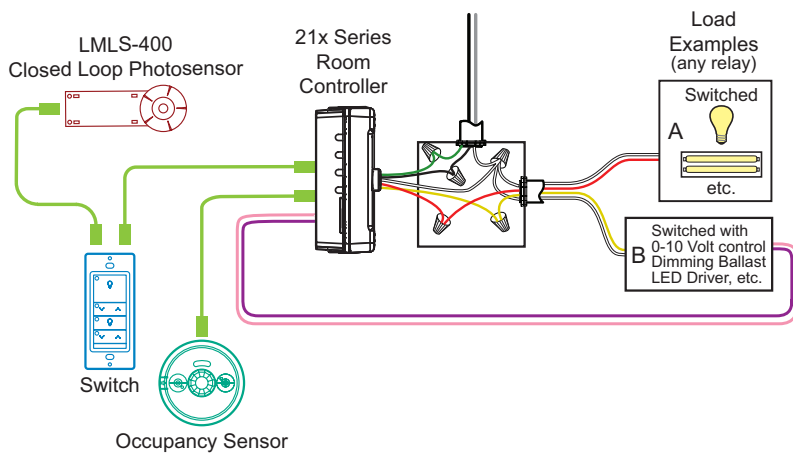

Plug DLM local network components together in any configuration using Cat 5e cables with RJ45 connectors.

ORDERING INFORMATION

Catalog #	Description
<input type="checkbox"/> LMLS-400	Digital Single Zone On/Off and Dimming Closed Loop Photosensor
<input type="checkbox"/> LMLS-400-U	Digital Single Zone On/Off and Dimming Closed Loop Photosensor, BAA/TAA compliant*
<input type="checkbox"/> LMLS-400-L	Digital Single Zone On/Off and Dimming Closed Loop Photosensor with extended tube,
<input type="checkbox"/> LMLS-400-L-U	Digital Single Zone On/Off and Dimming Closed Loop Photosensor with extended tube, BAA/TAA compliant*
<input type="checkbox"/> LMLS-MB1	Photosensor mounting bracket for J-box mounting
<input type="checkbox"/> LMLS-MB2	Photosensor mounting bracket for wall mount applications
<input type="checkbox"/> LMCT-100-2	Digital Wireless Configuration Tool with USB

*Product is compliant with Buy American Act and Trade Agreement Act

SINGLE ZONE SWITCHING AND DIMMING CLOSED LOOP DIGITAL PHOTOSENSOR

LMLS-400

Daylight responsive on/off, bi-level, tri-level or dimming control for one lighting zone

Extended tube model accommodates thicker ceiling materials

100 degree spatial response for optimal detection of ambient light level



Automatic calibration and configuration; optional hold off setting to maximize energy savings

Photodiode corrected to match the photopic response of the human eye

Can be calibrated in any daylight condition



DESCRIPTION

The LMLS-400 is a closed loop photosensor that measures the ambient light level in order to automatically switch or dim one zone of lighting. It is part of a Digital Lighting Management (DLM) system and sends light level signals to control loads connected to DLM on/off or dimming room controllers. The LMLS-400 has a photodiode with an extended range of 1-1,553 footcandles (fc), and photopic correction to mimic the human eye, for precise measurement of visible light.

OPERATION

The LMLS-400 operates on Class 2 power supplied to a DLM local network by one or more DLM room controllers. When there is one LMLS-400, Plug n' Go™ assigns load 1 to daylighting control. An LMCT-100-2 is used to assign additional loads, and assign loads to multiple photosensors. Following an automatic setup process, the LMLS-400 monitors the ambient light in the controlled space and works with the room controller(s) to maintain the design light level. Wattstopper's exclusive control algorithm uses on/off or dimming setpoints and other control parameters to establish the correct light levels throughout the day regardless of changing daylight contribution.

FEATURES

- Digital Lighting Management components plug together on a free-topology Cat 5e DLM local network
- Test mode override of programmed time delay allows easy verification of selected settings
- Load status verification allows confirmation and testing of controlled load
- Mounting options for hard ceilings, dropped ceilings and suspended lighting fixtures
- Infrared (IR) transceiver for wireless configuration and control
Compatible with DLM wall switches for manual override, if desired
- LED status indicators
- Complies with California Title 24, Section 119 requirements
- The product meets the materials restrictions of RoHS
- BAA/TAA-compliant models available

AUTOMATIC SETUP

After installation, the LMLS-400 measures the daylight and electric light levels in order to automatically calibrate itself and establish setpoints. This process may be initiated from the photosensor or a handheld LMCT-100-2 wireless configuration tool. The LMCT-100-2 may also be used to adjust setpoints and other parameters including hold off functionality. Adjustable switching parameters include on and off setpoints and time delays. The off setpoint can be adjusted to a value of 25, 50 (default), 75, or 100 percent above the on setpoint. Adjustable dimming parameters include day and night setpoints, ramp up and down rates, and a cut-off time delay. Electric lights can be turned off (default) or dimmed to a user-selectable minimum level when daylight contribution is abundant.

APPLICATIONS

The LMLS-400 photosensor is recommended for use in private offices, cafeterias, classrooms, atriums, lobbies and perimeter spaces with daylight contribution. It is designed to sense both daylight and electric light, and is typically ceiling mounted for sidelighting applications. The LMLS-400 can be used for on/off switching, bi-level or tri-level step switching or step dimming, or continuous dimming.

PROJECT

LOCATION/
TYPE

SPECIFICATIONS

- Input voltage: 24VDC from DLM local network
- Current consumption: 7mA
- DLM local network connection: 1 RJ45 port
- Digital multi-band photodiode with extended range: 1-1,553 fc (10-16,716 lux)
- Spatial response: 100°
- LED status and configuration indicators
- Infrared (IR) transceiver
- Weight: 1.4 oz (40 g)
- Operating conditions: for indoor use only; 32-131°F (0-55°C); less than 90% RH, non-condensing
- UL and cUL listed
- FCC part 15 compliant
- Five year warranty

DIMENSIONS & MOUNTING

Product Dimensions

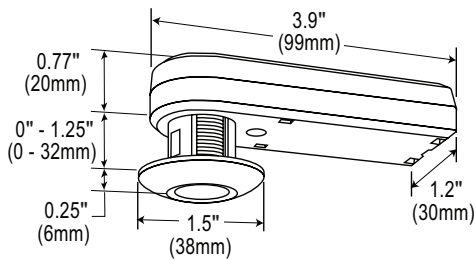

Placement for Sidelight Applications

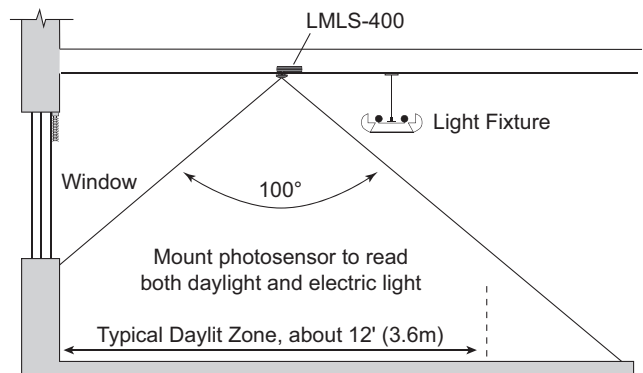

Mounting

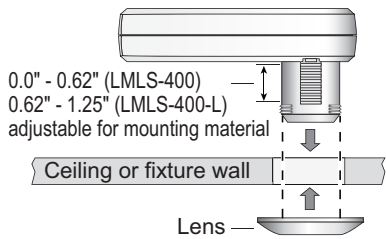

Mount in Ceiling

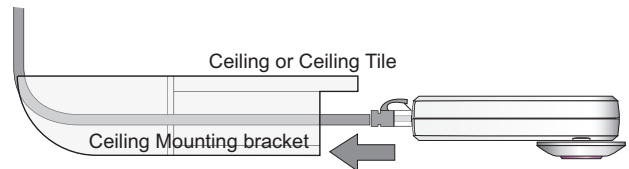

Mount to Ceiling with LMLS-MB2 bracket

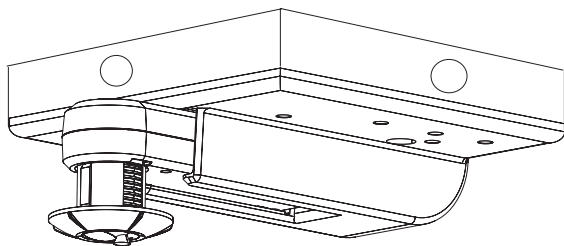

Mount to J-box with LMLS-MB1 bracket

PHOTODIODE RESPONSE

Spectral Response

The photodiode detects just visible light, which ensures accurate lighting control.

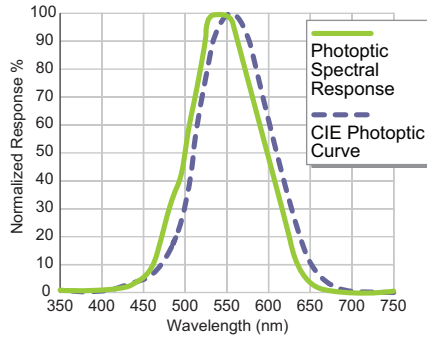

Spatial Response

Focused spatial response allows accurate detection of ambient light without interference from direct daylight or electric light sources.

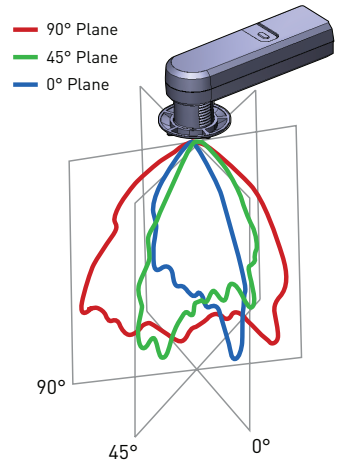

CONNECTING

Sample Connection Diagram for On/Off Switching Application

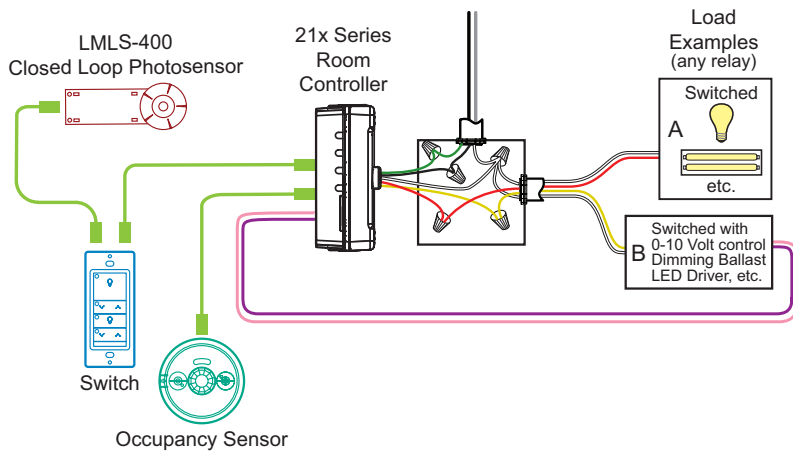

Plug DLM local network components together in any configuration using Cat 5e cables with RJ45 connectors.

ORDERING INFORMATION

Catalog #	Description
<input type="checkbox"/> LMLS-400	Digital Single Zone On/Off and Dimming Closed Loop Photosensor
<input type="checkbox"/> LMLS-400-U	Digital Single Zone On/Off and Dimming Closed Loop Photosensor, BAA/TAA compliant*
<input type="checkbox"/> LMLS-400-L	Digital Single Zone On/Off and Dimming Closed Loop Photosensor with extended tube,
<input type="checkbox"/> LMLS-400-L-U	Digital Single Zone On/Off and Dimming Closed Loop Photosensor with extended tube, BAA/TAA compliant*
<input type="checkbox"/> LMLS-MB1	Photosensor mounting bracket for J-box mounting
<input type="checkbox"/> LMLS-MB2	Photosensor mounting bracket for wall mount applications
<input type="checkbox"/> LMCT-100-2	Digital Wireless Configuration Tool with USB

*Product is compliant with Buy American Act and Trade Agreement Act