



Compact Fluorescent

**Promenade**  
Energy Star® Qualified

**Outdoor**

Type \_\_\_\_\_  
-31WB

- P6033
- P6034
- P6035

Catalog No.	Finish		Lamping	Dimensions (Inches)			
	Black			A	B	C	D
P6033	-31WB		1-13w GU-24 (included)	6-1/2	10-3/4	7-3/4	4-1/8
P6034	-31WB		1-26w GU-24 (included)	8-1/2	13-3/4	9-3/4	4-1/8
P6035	-31WB		1-26w GU-24 (included)	10-1/2	16-7/8	12	5-1/8

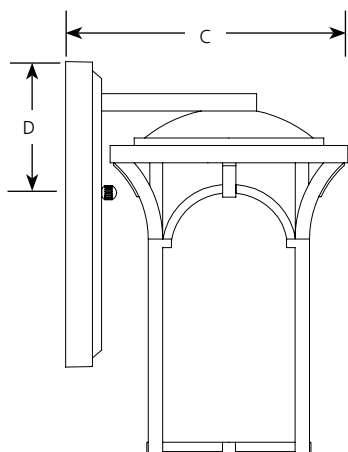

**P6033 side view**

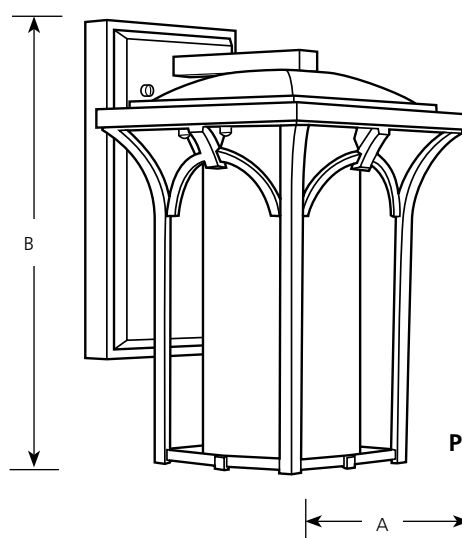

**P6033**

**Specifications:**

General

- Etched opal glass cylindrical diffuser  
P6033: 3-3/4" dia., 8-1/16" ht.  
P6034: 4-3/4" dia., 10-9/16" ht.  
P6035: 5-3/4" dia., 13-1/16" ht.
- Painted Black (-31WB) finish
- Cast aluminum construction
- GU24 base lamp (included)
- Energy Star® qualified
- Companion Chain hung lantern, Post top lantern, Wall lantern, fixtures are available

Mounting

- Wall mount
- Back plate covers a standard 4" hexagonal recessed outlet box
- Mounting strap for outlet box included

Electrical

- GU24 base socket
- Pre-wired

Labeling

- cCSAus Wet location listed



Progress Lighting  
701 Millennium Blvd.  
Greenville, South Carolina  
29607

www.progresslighting.com

Rev. 10/13